

Towing connections

- 8-1 Light trailer drawbar and kingpin
- 8-2 Towbar
- 8-3 Drawbar
- 8-4 Drawbeam
- 8-5 Agricultural trailer towing connection
- 8-6 Heavy vehicle fifth wheel or ball coupling (for towing a semi-trailer)
- 8-7 Heavy vehicle kingpin or socket coupling (for towing a semi-trailer)

Towing connections

8-1 Light trailer drawbar and kingpin

Summary of legislation

Applicable legislation

- Land Transport Rule: Light-Vehicle Brakes 2002
- Land Transport Rule: Vehicle Standards Compliance 2002, section 7.4

Mandatory equipment

1. A trailer must be securely attached to the towing vehicle by an adequate coupling.
2. A trailer with a laden weight of 2000 kg or less without a compliant breakaway brake must have a securely attached safety chain or cable, unless the trailer is one of the following:
 - a) a trailer designed for armament purposes by the New Zealand Defence Force.
 - b) a trailer pump for fire fighting purposes.
3. A trailer with a laden weight between 2001 kg and 2500 kg that does not have a compliant breakaway brake must be fitted with two safety chains that comply with standard ADR 62 (determination 2, 1995) and that cross each other when connected.

Condition

4. A trailer must be securely attached to the towing vehicle by an adequate coupling.
5. A safety chain or cable must be of sufficient strength to hold the trailer secure under all conditions of road use.
6. A trailer must:
 - a) be safe to be operated, and
 - b) have been constructed using components and materials that are fit for the purpose, and
 - c) be within safe tolerance of its state when manufactured or modified.

Reasons for rejection

Mandatory equipment

1. A trailer with a GVM of 2000 kg or less without a compliant breakaway brake, except for the following trailers, does not have a safety chain or cable (**Note 2**):
 - a) a trailer designed for armament purposes by the New Zealand Defence Force.
 - b) a trailer pump for fire fighting purposes.
2. A trailer with a laden weight between 2001 kg and 2500 kg (where the vehicle inspector is able to determine the laden weight) that does not have a compliant breakaway brake (**Note 2**):
 - a) is not fitted with two safety chains that cross each other when connected, or
 - b) has a safety chain fitted to the drawbar by means of a shackle, or
 - c) has chain links with a material cross-section less than 7.1 mm, or there is no evidence that each chain has a breaking strength of at least twice the laden weight of the trailer.

Condition

3. The drawbar or drawbar mounting (or kingpin or kingpin mounting):
 - a) is not securely attached, or
 - b) has a bolt or nut that is missing or significantly corroded, or
 - c) has corrosion damage (**Note 1**) within 150 mm of a mounting point, or
 - d) is cracked or distorted.
4. The drawbar coupling (or kingpin):
 - a) is not securely attached, or
 - b) is not mounted in accordance with manufacturer's specifications, or
 - c) is worn beyond the manufacturer's specifications, or
 - d) is significantly corroded, distorted or cracked, or
 - e) has a nut that is missing or significantly corroded.

Towing connections

8-1 Light trailer drawbar and kingpin (cont.)

Reasons for rejection

5. A safety chain or cable (including any welded joint, securing bolt or shackle):
 - a) is not securely attached to the drawbar, or
 - b) is welded to the drawbar, and
 - i. there is no clear evidence of weld penetration, or
 - ii. the weld metal has not been applied in accordance with good trade practice, or
 - iii. there is no evidence that the chain can be welded without reducing its strength, or
 - iv. the weld is significantly corroded, has deteriorated or is cracked.
 - c) is significantly corroded, distorted or cracked, or
 - d) has a bolt or shackle that is missing, significantly corroded, distorted or cracked, or
 - e) appears to be too weak to withstand a load of about twice the likely maximum laden weight (as far as can be reasonably estimated by the inspector).

Note 1 Corrosion damage is where the metal has been eaten away, which is evident by pitting. The outward signs of such corrosion damage is typically displayed by the lifting or bubbling of paint. In extreme cases, the area affected by the corrosion damage will fall out and leave a hole.

Note 2 If a trailer **does** have a functional brakeaway brake, then it **must not** be fitted with safety chains.

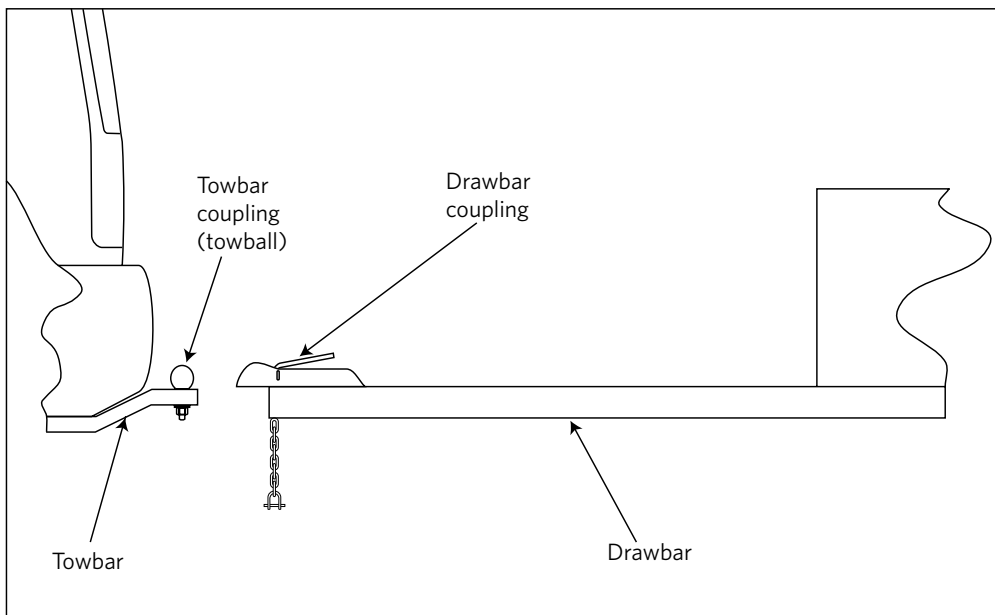

Figure 8-1-1. Tow coupling components

Towing connections 8-2 Towbar

Summary of legislation

Applicable legislation

- Land Transport Rule: Heavy Vehicles 2004
- New Zealand Standard 5467: 1993, Code of Practice for Light Trailers
- New Zealand Standard 5446: 1987, Code of Practice for Heavy Motor Vehicle Towing Connections: Drawbar Trailers
- Policy Statement 5, Appendix A
- New Zealand Standard 5232: 1993, Specifications for Ball-and-Socket Type Trailer Couplings

Mandatory requirement

1. A towbar fitted to a heavy trailer before 1 April 2006 must comply with and be certified to:
 - a) NZS 5467: 1993, or
 - b) NZS 5446: 1987, or
 - c) NZS 5446: 1987, amended by appendix A to Policy Statement 5 for towbars rated for a maximum towed mass of 2000 kg or less.
2. A towbar fitted to a heavy trailer on or after 1 April 2006 for towing a light trailer must comply with and be certified to NZS 5467: 1993.

Mandatory equipment

3. A towbar, if fitted to a vehicle, must have provision for securing the safety chain or cable from a trailer coupling, except if the vehicle is likely to tow any of the following trailers:
 - a) a trailer designed for armament purposes by the New Zealand Defence Force.
 - b) a trailer pump for fire-fighting purposes.

Condition

4. Towing connection components fitted to a vehicle must ensure that a secure connection can be maintained between the towing and towed vehicles under all conditions of loading and operation for which the vehicle was constructed.

Modification and repair

5. A modification or repair that affects the towbar must be inspected and certified by an HVS certifier of category HVET, HVMT or HVIT, unless the vehicle:
 - a) is excluded from the requirement for HVS certification (**Table 8-2-2**), and
 - b) has been inspected in accordance with the requirements in this manual, including those for equipment, condition and performance.

Reasons for rejection

Mandatory requirement

1. A towbar fitted to a heavy vehicle does not have evidence of certification, ie:
 - a) the towbar was fitted before the last CoF inspection, and after 1 January 1997, and no LANDATA record has been entered

Note Before 1 January 1997 certification was required but for inspection purposes the LANDATA record need not be checked

or
 - b) the towbar was fitted after the last CoF inspection and
 - i. a valid LT400 form has not been presented, or
 - ii. the HVS certifier was not of category HVET, HVMT, HVIT, or
 - c) there is no valid certification plate or label attached to the vehicle as required in **Table 8-2-1**.
2. A towbar fitted to a heavy vehicle before 1 April 2006 for towing a light trailer has not been certified as complying with at least one of the following:
 - a) NZS 5467: 1993, or
 - b) NZS 5446: 1987, or
 - c) NZS 5446: 1987, amended by Appendix A to Policy Statement 5 for towbars rated for a maximum towed mass of 2000 kg or less.
3. A towbar fitted to a heavy vehicle on or after 1 April 2006 for towing a light trailer has not been certified as complying with NZS 5467: 1993.
4. The certification label or plate:
 - a) is not indelible, or
 - b) is illegible, or
 - c) is not complete, or
 - d) has expired (where expiry date is required under **Table 8-2-1**), or
 - e) is not attached to the drawbeam in an easily visible position, or

Towing connections

8-2 Towbar (cont.)

Reasons for rejection

- f) does not match the vehicle, or
 - g) has obvious signs of tampering.
5. A 50 mm or 1 7/8 inch diameter tow ball for towing a light trailer is not marked with:
- a) the ball size, that is 50 mm or 1 7/8 inch, or
 - b) the ball rating in kilograms.

Mandatory equipment

6. A towbar does not have provision for securely fitting the safety chain from a trailer coupling, except for:
- a) New Zealand Defence Force vehicles.
 - b) fire fighting vehicles.

Condition

7. The towbar or towbar mounting:
- a) is not securely attached, or
 - b) has a bolt or nut that is missing or significantly corroded, or
 - c) has corrosion damage within 150 mm of the mounting points, or
 - d) is cracked or distorted.
8. The towbar coupling (tow ball):
- a) is not securely attached, or
 - b) is worn beyond manufacturer's specifications, or
 - c) is significantly corroded, distorted or cracked, or
 - d) has a nut that is missing or significantly corroded.

Modification and repair

9. A modification or repair affects the towbar and:
- a) is not excluded from the requirements for HVS certification (**Table 8-2-2**), or
 - b) the modification is not for the purpose of law enforcement or the provision of emergency services, or
 - c) is missing proof of HVS certification, ie:

Reasons for rejection

- i. the vehicle was modified or repaired before the last CoF inspection and no LANDATA record has been entered, or
- ii. the vehicle was modified or repaired since the last CoF inspection and no valid LT400 form from an HVS certifier of category HVET, HVMT or HVIT has been presented.

Table 8-2-1. Minimum information on towbar certification label/plate

NZS 5467	NZS 5446	NZS 5446 as amended by Appendix A to Policy Statement 5
Manufacturer's name or trademark Maximum towed mass (braked and unbraked) Model (vehicle make, model or part number) Maximum vertical load	Company or agency name Certifying engineer Vehicle VIN or chassis number Maximum towed mass (kg) Expiry date (if certified after August 1991)	Manufacturer's name Towbar model number or part number Rating - maximum towed mass (MTM) in kg (maximum of 2000 kg)

Table 8-2-2. Requirements for HVS certification

HVS certification is required	HVS certification is not required
1. Fitting of a towbar	1. Replacement bolt-on 50 mm or 1 7/8 inch diameter tow ball 2. Any modification or repair likely to have been carried out before 1 January 1997 (modifications and repairs before this date generally required certification but for inspection purposes the LANDATA record need not be checked). 3. Any repair or modification not listed in the left-hand column unless the vehicle inspector considers that certification is required because the modification or repair has affected the vehicle's safety performance (a second opinion from an expert may be needed, eg the manufacturer's representative, or a reputable workshop).

Note 1 Towbar means that part of the towing vehicle to which a coupling for a light trailer is connected.

Coupling means that part of a vehicle that is specifically designed to enable it to be connected to another vehicle; does not include a structural member of the towing or towed vehicle (examples: fifth wheel, hook, pin, ball or socket type).

Light trailer means a trailer that has a gross vehicle mass of 3500 kg or less.

Towing connections

8-3 Drawbar

Summary of legislation

Applicable legislation

- Land Transport Rule: Heavy Vehicles 2004
- Land Transport Rule: Vehicle Dimensions and Mass 2002
- New Zealand Standard 5446: 1987, Code of Practice for Heavy Motor Vehicle Towing Connections: Drawbar Trailers
- New Zealand Standard 5446: 2007, Heavy Vehicle Towing Connections – Drawbeams and Drawbars

Mandatory requirement

1. A drawbar fitted to a vehicle used in a combination (other than an agricultural trailer to which section 8-5 applies) must comply with NZS 5446.
2. For a pole trailer that carries its load as a rigid single span secured to both the towing vehicle and the pole trailer:
 - a) the maximum towed mass of the drawbar must be equal to or greater than the unladen mass of the pole trailer, and
 - b) the certification plate attached to the drawbar must state that the maximum towed mass applies only when the trailer is unladen.

Mandatory and permitted equipment

3. A socket-type coupling must have an effective locking device and a separate means of retaining this device in the locked position.
4. A drawbar on a full trailer must not be extendable except as follows:
 - a) to facilitate the loading of livestock or goods, provided the drawbar has only one set of locking pin holes positioned so that the drawbar is fully extended when locked,
 - b) a logging trailer with a drawbar that has no more than:
 - i. one sliding position for long logs.
 - ii. one or two fixed positions for short logs.
 - iii. a fixed position for storage of the drawbar when it is out of use while the trailer is being transported.
5. A telescopic drawbar must have endstops or a secondary locking device to prevent separation if the primary locking device fails.

Condition

6. Towing connection components fitted to a vehicle must ensure that a secure connection can be maintained between the towing and towed vehicles under all conditions of loading and operation for which the vehicle was constructed.

Reasons for rejection

Mandatory requirement

1. A drawbar fitted to a heavy trailer (other than an agricultural trailer to which section 8-5 applies) does not have evidence of certification as complying with NZS 5446, ie:
 - a) the drawbar was fitted before the last CoF inspection, and after 1 January 1997, and no LANDATA record has been entered, or

Note Before 1 January 1997 certification was required but for inspection purposes the LANDATA record need not be checked)
 - b) the drawbar was fitted after the last CoF inspection and:
 - i. a valid LT400 form has not been presented, or
 - ii. the HVS certifier was not of category HVET, HVMT, HVIT, or
 - c) the drawbar is not fitted with a certification label (**Table 8-3-1**).
2. The certification label:
 - a) is not indelible, or
 - b) is illegible, or
 - c) is not complete, or
 - d) is not attached to the drawbar in an easily visible position, or
 - e) does not match the vehicle, or
 - f) has obvious signs of tampering, or
 - g) has expired.
3. For a pole trailer that carries its load as a rigid single span secured to both the towing vehicle and the pole trailer:
 - a) the maximum towed mass of the drawbar is not equal to or greater than the unladen mass of the pole trailer, or
 - b) the certification plate attached to the drawbar does not state that the maximum towed mass applies only when the trailer is unladen.

Towing connections

8-3 Drawbar (cont.)

7. A drawbar on a full trailer may have only one operating position.
8. Locking off the coupling must be readily verifiable by visual inspection.

Modification and repair

9. A modification or repair that affects the drawbar must be inspected and certified by an HVS certifier of category HVET, HVMT or HVIT.

Reasons for rejection

Mandatory and permitted equipment

4. A full trailer (other than a logging trailer, or a trailer designed for the through loading of livestock or goods, or a trailer with an adjustable drawbar fitted before 1 July 2002):
 - a) is fitted with a telescopic or sliding drawbar, or
 - b) has a drawbar with more than one on-road operating position.
5. A permitted retractable drawbar on a stock or goods trailer that is a full trailer has:
 - a) no locking pin holes, or
 - b) more than one set of locking pin holes, or
 - c) locking pin holes that are not positioned so that the drawbar is fully extended when locked.
6. A telescopic drawbar on a logging trailer that is a full trailer has more than:
 - a) one sliding position for long logs, or
 - b) two fixed positions for short logs, or
 - c) one fixed position for storage of the drawbar when it is out of use while the trailer is being transported.
7. A telescopic or sliding drawbar does not have endstops or a secondary locking device to prevent separation if the primary locking device fails.
8. A socket-type coupling does not have a locking device or a separate means of retaining this device in the locked position.

Condition and performance

9. A towing connection component is:
 - a) damaged, deformed, cracked or has significantly deteriorated, or
 - b) worn beyond manufacturer's specifications, or
 - c) not securely attached, or
 - d) missing, or
 - e) not mounted in accordance with manufacturer's specifications, or
 - f) not protected from striking the ground.

Reasons for rejection

10. The towing eye:
 - a) is not protected from striking the ground, or
 - b) is worn beyond (**Note 1**):
 - i. 41.6 mm for a 40 mm towing eye, or
 - ii. 51.5 mm for a 50 mm towing eye, or
 - c) has been repaired, or
 - d) is the demountable type and has been welded, or
 - e) is the weld-in type and has been welded other than parallel to the shank (**Figure 8-3-3**) or as permitted by the towing eye manufacturer.
11. Locking of the coupling is not readily verifiable by visual inspection.
12. A coupling locking device is in such condition that it is not effective.
13. A telescopic or sliding drawbar:
 - a) endstop is not substantial enough to be effective, or
 - b) locking device is in such condition that it is not effective.
14. A drawbar pivot (hinge) pin/bush clearance is more than 1/8th of the pin diameter (eg for a 24 mm pin, the clearance is more than 3 mm).
15. The drawbar or drawbar mounting has corrosion damage within 150 mm of a mounting point.
16. A drawbar on a full trailer has more than one operating position.

Modification and repair (**Note 3**)

17. A modification or repair affects the drawbar and:
 - a) is not for the purpose of law enforcement or the provision of emergency services, or
 - b) is missing proof of HVS certification, ie:
 - i. the vehicle was modified or repaired before the last CoF inspection, and after 1 January 1997, and no LANDATA record has been entered, or

Note Before 1 January 1997 certification was required but for inspection purposes the LANDATA record need not be checked)

Towing connections

8-3 Drawbar (cont.)

Reasons for rejection

- ii. the vehicle was modified or repaired since the last CoF inspection and no valid LT400 form from an HVS certifier of category HVET, HVMT or HVIT has been presented.

Note 1 Manufacturer's wear limits may be used instead of those stated.

Note 2 Agricultural trailer means a trailer constructed to be operated in connection directly with the operation or management of a farm; does not include a logging trailer.

Coupling means that part of a vehicle that is specifically designed to enable it to be connected to another vehicle; does not include a structural member of the towing or towed vehicle (eg: fifth wheel, hook, pin, ball or socket type).

Drawbar means an assembly of components that includes the trailer coupling that connects the trailer to the coupling of the towed vehicle, hinges (where applicable), and the structural and other related components between the trailer coupling and trailer bogie or chassis.

Pole trailer means a trailer that is attached to a towing vehicle by a telescoping or sliding pole, and is designed to support a common long load spanning between the trailer and the towing vehicle.

Note 3 A towing connection that was certified to New Zealand Standard 5446: 1987 (superceded) before November 2007 may continue to comply with and be certified to that standard until the towing connection is modified.

Note 4 Some special-use vehicles, such as fertiliser trucks and trailers, are fitted with towing connections where the towing eye is fitted to the towing vehicle and the pin- or hook-type coupling to the trailer. This is permitted. In these cases, please refer to section 8-4 for wear limits and other relevant requirements.

Table 8-3-1. Minimum information on drawbar certification label/plate

NZS 5446: 1987	NZS 5446: 2007
Company or agency name	Person, company or agency name
Certifying engineer	Certifier ID
VIN/Chassis number	Compliance certificate number (LT400)
Maximum towed mass (kg)	VIN/Chassis number
Expiry date (if certified on or after 1 August 1991)	Maximum towed mass
	Maximum static vertical load
	Coupling D value (minimum)
	Drawbar length
	Turntable lock (Yes/No)
	Expiry date
	NZS 5446

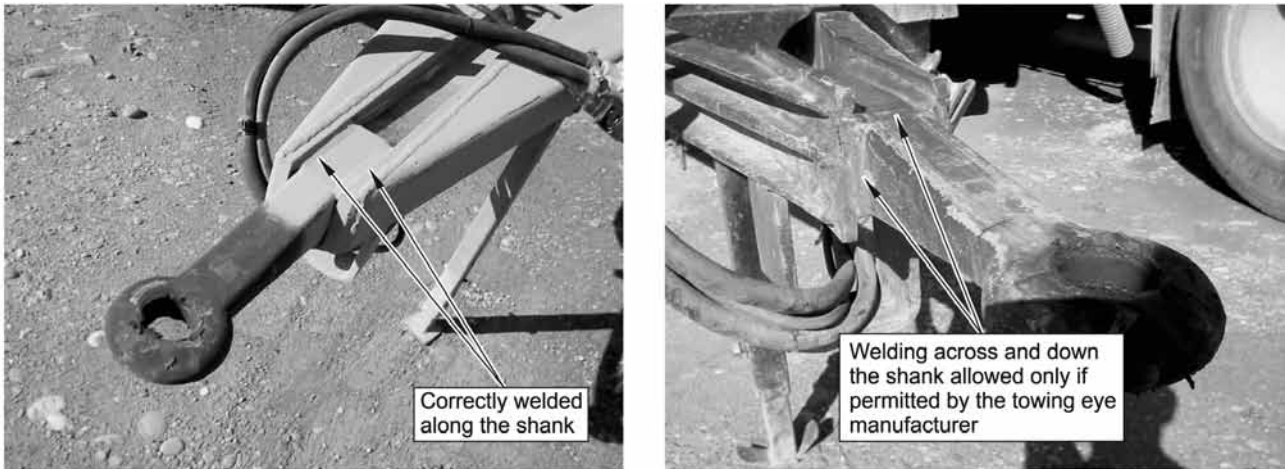

Figure 8-3-1. Permitted welding on towing eye shank

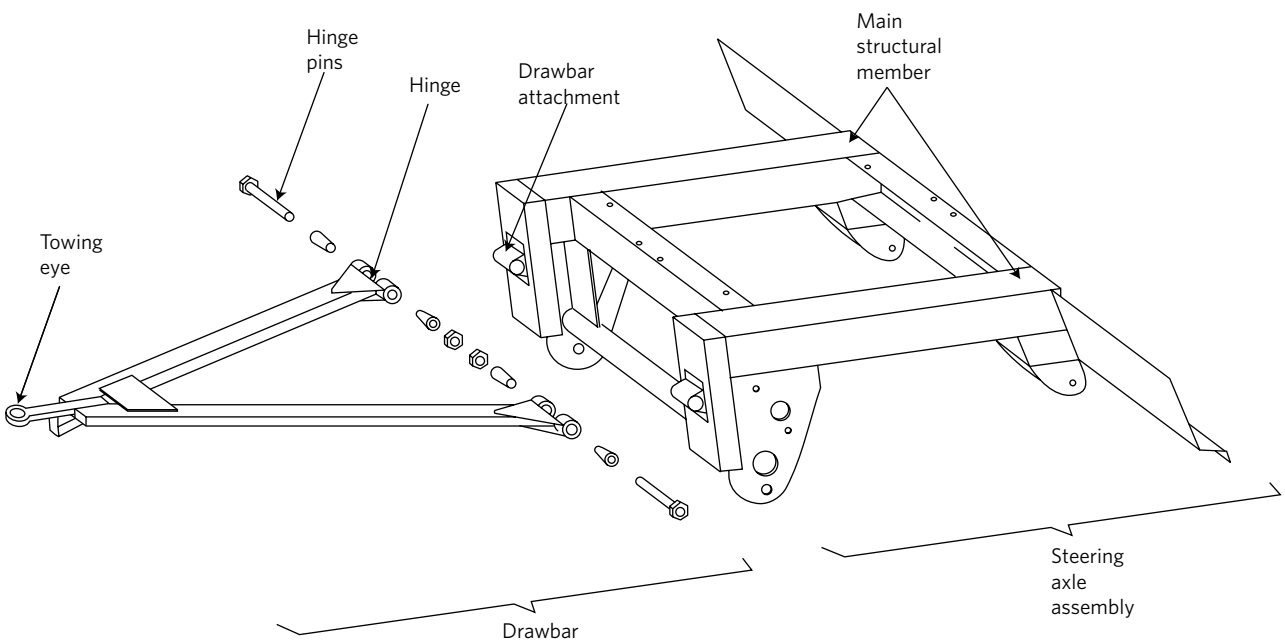

Figure 8-3-2. Drawbar components

Towing connections

8-4 Drawbeam

Summary of legislation

Applicable legislation

- Land Transport Rule: Heavy Vehicles 2004
- Land Transport Rule: Vehicle Dimensions and Mass 2002
- New Zealand Standard 5446: 1987, Code of Practice for Heavy Motor Vehicle Towing Connections: Drawbar Trailers
- New Zealand Standard 5446: 2007, Heavy Vehicle Towing Connections - Drawbeams and Drawbars

Mandatory equipment

1. A drawbeam fitted to a heavy trailer, other than an agricultural trailer to which section 8-5 applies, used in a combination, must comply with New Zealand Standard 5446: 1987, Code of Practice for Heavy Motor Vehicle Towing Connections: Drawbar Trailers.
2. A hook- or pin-type coupling must have an effective locking device and a separate means of retaining this device in the locked position.

Condition and performance

3. Towing connection components fitted to a vehicle must ensure that a secure connection can be maintained between the towing and towed vehicles under all conditions of loading and operation for which the vehicle was constructed.
4. A drawbeam used for towing a full trailer must not be sliding or adjustable.
5. Locking of the coupling must be readily verifiable by visual inspection.

Modification and repair

6. A modification or repair that affects the drawbeam must be inspected and certified by an HVS certifier of category HVET, HVMT or HVIT.

Reasons for rejection

Mandatory requirement

1. A drawbeam fitted to a heavy trailer, other than an agricultural vehicle to which section 8-5 applies or a recovery service vehicle, does not have evidence of certification to NZS 5446, ie:
 - a) the drawbeam was fitted before the last CoF inspection, and after 1 January 1997, and no LANDATA record has been entered, or

Note Before 1 January 1997 certification was required but for inspection purposes the LANDATA record need not be checked
 - b) the drawbeam was fitted after the last CoF inspection and
 - i. a valid LT400 form has not been presented, or
 - ii. the HVS certifier was not of category HVET, HVMT, HVIT, or
 - c) there is no valid certification label or plate attached to the vehicle as required in **Table 8-4-1**.
2. The certification label or plate:
 - a) is not indelible, or
 - b) is illegible, or
 - c) is not complete, or
 - d) is not attached to the drawbeam in an easily visible position, or
 - e) does not match the vehicle, or
 - f) has obvious signs of tampering, or
 - g) has expired.

Mandatory equipment

3. A hook- or pin-type coupling does not have a locking device or a separate means of retaining this device in the locked position.

Condition and performance

4. A towing connection component is:
 - a) damaged, deformed, cracked or has significantly deteriorated, or

Towing connections

8-4 Drawbeam (cont.)

Reasons for rejection

- b) worn beyond manufacturer's specifications, or
 - c) not securely attached, or
 - d) missing, or
 - e) not mounted in accordance with manufacturer's specifications.
5. Locking of the coupling is not readily verifiable by visual inspection.
 6. A coupling locking device is in such condition that it is not effective.
 7. The towing pin diameter is worn to less than (**Note 1**):
 - a) 36.4 mm for a 40 mm pin, or
 - b) 46.4 mm for a 50 mm pin.
 8. A towing hook or pin has been repaired or welded.
 9. Towing connection components fitted to a vehicle must ensure that a secure connection can be maintained between the towing and towed vehicles under all conditions of loading and operation for which the vehicle was constructed.
 10. A drawbeam designed for towing a full trailer is sliding or adjustable.

Modification and repair (**Note 3**)

11. A modification or repair affects the drawbeam and:
 - a) the modification is not for the purpose of law enforcement or the provision of emergency services, or
 - b) is missing proof of HVS certification, ie:
 - i. the vehicle was modified or repaired before the last CoF inspection, and after 1 January 1997, and no LANDATA record has been entered, or
- Note** Before 1 January 1997 certification was required but for inspection purposes the LANDATA record need not be checked
- ii. the vehicle was modified or repaired since the last CoF inspection and no valid LT400 form from an HVS certifier of category HVET, HVMT or HVIT has been presented.



Note 1 Manufacturer's wear limits may be used instead of those stated.

Note 2 Coupling means that part of a vehicle that is specifically designed to enable it to be connected to another vehicle; it does not include a structural member of the towing or towed vehicle (eg fifth wheel, hook, pin, ball or socket type).

Drawbeam means that part of the towing vehicle to which a coupling is fitted to enable a heavy trailer to be connected; it includes the attached coupling.

Full trailer means a trailer with two axle sets, the foremost of which is steered by a drawbar; it includes a semi-trailer with non-steering axles coupled to a converter dolly.

Note 3 A towing connection that was certified to New Zealand Standard 5446: 1987 (superseded) before November 2007 may continue to comply with and be certified to that standard until the towing connection is modified.

Table 8-4-1. Minimum information on drawbeam certification label/plate

NZS 5446: 1987	NZS 5446: 2007
Company or agency name	Person, company or agency name
Certifying engineer	Certifier ID
VIN/Chassis number	Compliance certificate number (LT400)
Maximum towed mass (kg)	VIN/Chassis number
Expiry date (if certified on or after 1 August 1991)	Maximum towed mass
	Permitted static vertical load
	Coupling D value (minimum)
	Expiry date
	NZS 5446

Towing connections

8-4 Drawbeam (cont.)

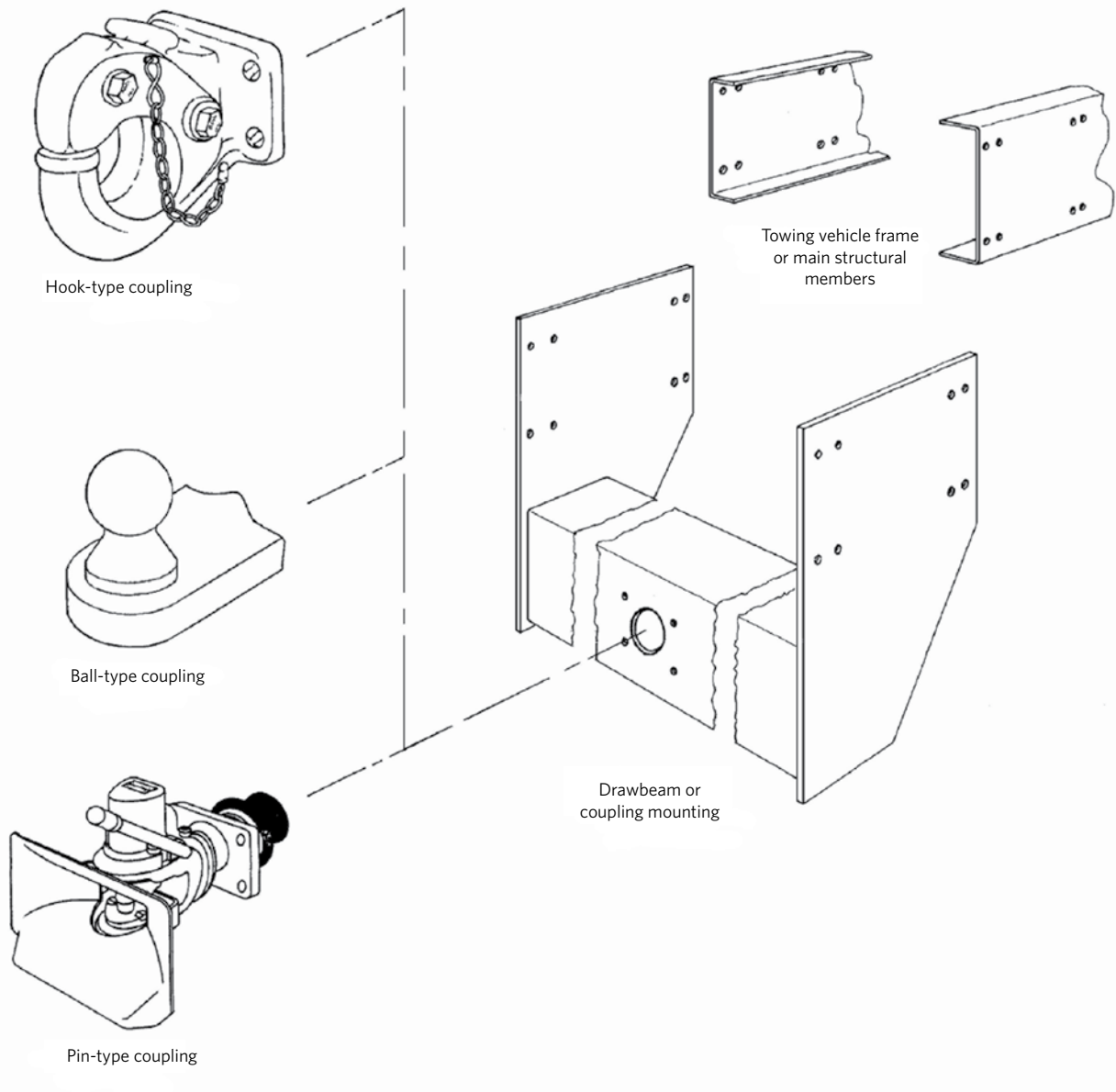

Figure 8-4-3. Drawbeam components

Reproduced from Figure 3 of NZS 5446: 2007 with the permission of Standards New Zealand under Licence 000711

Towing connections

8-5 Agricultural trailer towing connection

Summary of legislation

Applicable legislation

- Land Transport Rule: Heavy Vehicles 2004

Mandatory equipment

- An agricultural trailer fitted with a towing connection other than a two- or three-point agricultural linkage must have either one or two safety chains fitted that meet the requirements in **Table 8-5-1**.

Condition

- Towing connection components fitted to a vehicle must ensure that a secure connection can be maintained between the towing and towed vehicles under all conditions of loading and operation for which the vehicle was constructed.

Reasons for rejection

Mandatory equipment

- An agricultural trailer fitted with a towing connection other than a two- or three-point agricultural linkage does not have either one or two safety chains fitted that meet the requirements in **Table 8-5-1**.

Condition

- A towing connection component including a safety chain is:
 - damaged, deformed, cracked or has significantly deteriorated, or
 - worn beyond manufacturer's specifications, or
 - has corrosion damage within 150 mm of a mounting point, or
 - not securely attached, or
 - missing, or
 - not mounted in accordance with manufacturer's specifications, or
 - welded, and the weld metal has not been applied in accordance with good trade practice.
- A safety chain or its attachment point is not of sufficient strength to withstand a load of at least twice the trailer's likely maximum laden weight.

Table 8-5-1. Agricultural trailer safety chain requirements

Single safety chain fitted	Permanently attached to the trailer (direct welding of chain to trailer is not permitted) Chain length must allow full articulation and prevent contact of coupling with the ground in case of coupling failure If practicable, be attached to a component that cannot be readily removed from the trailer
Two safety chains fitted	The two chains must cross each other when connected to the towing vehicle Must not be connected to the drawbar by means of shackles

Note 1 **Agricultural trailer** means a trailer constructed to be operated in connection directly with the operation or management of a farm; does not include a logging trailer.

Three-point linkage means, for a tractor or agricultural trailer, a towing connection that has three points of attachment.

Towing connection means the combination of components that enables one vehicle to tow or be towed by another vehicle; it includes a towbar, drawbar, drawbeam and coupling.

Two-point linkage means, for an agricultural trailer, a towing connection that has two points of attachment.

Towing connections

8-6 Heavy vehicle fifth wheel or ball coupling (for towing a semi-trailer)

Summary of legislation

Applicable legislation

- Land Transport Rule: Heavy Vehicles 2004
- New Zealand Standard 5450: 1989, Coupling Devices for Articulated Vehicles – Fifth Wheel Assemblies
- Australian Standard 1773-1996: Articulated Vehicles – Fifth Wheel Assemblies
- Australian Standard 1771-1996: Installation of Fifth Wheel and Turntable Assemblies
- Australian Standard 2174-1994: Articulated Vehicles – Mechanical Coupling between Prime Movers and Semi-Trailers – Interchangeability Requirements
- New Zealand Standard 5446: 1987, Code of Practice for Heavy Motor Vehicle Towing Connections: Drawbar Trailers
- New Zealand Standard 5446: 2007, Heavy Vehicle Towing Connections – Drawbeams and Drawbars

Mandatory equipment

1. A trailer that is constructed to tow a semi-trailer must be fitted with either:
 - a) a 50 mm diameter fifth wheel, or
 - b) a 90 mm diameter fifth wheel, or
 - c) a ball-type coupling certified to NZS 5446 and be operated as part of a dedicated coupling.
2. A 50 mm diameter fifth wheel must comply with New Zealand Standard 5450: 1989.
3. A 90 mm diameter fifth wheel installed before 1 April 2005 must comply with New Zealand Standard 5450: 1989.
4. A 90 mm diameter fifth wheel installed on or after 1 April 2005 and before 29 December 2007 must comply with:
 - a) Australian Standard 1773-1996 (**Note 1**), and
 - b) Australian Standard 1771-1996 (**Note 1**), and
 - c) Australian Standard 2174-1994.
5. A 90 mm diameter fifth wheel installed on or after 29 December 2007 must comply with:
 - a) AS/NZS 4968.1-2003, and
 - b) AS/NZS 4968.2-2003, and
 - c) AS 2174-2006.
6. A trailer that is fitted with a 90 mm diameter fifth wheel must have clearly displayed, in a position readily visible from the position from which the release handle of the fifth wheel is operated, '90 mm fifth wheel' where '90' must be not less than 60 mm high.
7. A rigid fifth wheel fitted to a trailer must be installed and maintained in accordance with the fifth-wheel manufacturer's instructions.

Reasons for rejection

Mandatory equipment

1. A fifth wheel is not designed to fit a 50 mm or 90 mm kingpin.
2. A fifth wheel or ball-type coupling fitted to a heavy trailer does not have evidence of certification (unless excepted in **Table 8-6-1**), ie:
 - a) the coupling was fitted before the last CoF inspection, and after 1 January 1997, and no LANDATA record has been entered, or

Note Before 1 January 1997 certification was required but for inspection purposes the LANDATA record need not be checked
 - b) the coupling was fitted after the last CoF inspection and
 - i. a valid LT400 form has not been presented, or
 - ii. the HVS certifier was not of category HVET, HVIT or HVMT.
3. A 50 mm diameter fifth wheel, other than a rigid fifth wheel, has not been certified to NZS 5450: 1989.
4. A 90 mm diameter fifth wheel, other than a rigid fifth wheel, has not been certified to one of the following:
 - a) if fitted before 1 April 2005, NZS 5450, or
 - b) if fitted on or after 1 April 2005, both AS 2174 and AS/NZS 4968 (**Note 1**).
5. A rigid fifth wheel has not been certified to manufacturer's specifications.
6. A heavy trailer that is fitted with a 90 mm diameter fifth wheel does not have '90 mm fifth wheel', where '90' is at least 60 mm high, clearly displayed in a position readily visible from the position from which the release handle of the fifth wheel is operated.
7. An 'Operator Statement of Compliance with the Maintenance Requirements of NZS 5450: 1989' (LTSA4085A form) is:
 - a) not presented, or
 - b) incomplete (**Note 2**), or
 - c) not current, that is more than:

Towing connections

8-6 Heavy vehicle fifth wheel or ball coupling (for towing a semi-trailer) (cont.)

Condition

8. Towing connection components fitted to a trailer must ensure that a secure connection can be maintained between the towing and towed vehicles under all conditions of loading and operations for which the vehicle was constructed.

Modification and repair

9. A modification or repair that affects the coupling must be inspected and certified by an HVS certifier of category HVET, HVMT or HVIT, unless the vehicle:
- excluded from the requirement for HVS certification (**Table 8-6-1**), and
 - has been inspected in accordance with the requirements in this manual, including those for equipment, condition and performance.

Reasons for rejection

- the time or distance specified by the fifth wheel manufacturer has elapsed or been travelled since the most recent inspection recorded on the form, or
 - 30 days have lapsed or 15,000 km has been travelled, whichever occurred sooner, since the most recent inspection recorded on the form, where manufacturer's specifications are unavailable.
8. A vehicle is fitted with a ball type coupling to tow a semi-trailer and:
- is not certified to NZS 5446, or
 - does not have a valid certification label or plate attached to the vehicle as required in **Table 8-6-2**, or
 - is not part of a dedicated combination (**Note 6**).
9. A required certification label or plate:
- is not indelible, or
 - is illegible, or
 - is not complete, or
 - is not attached to the vehicle in an easily visible position, or
 - does not match the vehicle, or
 - has obvious signs of tampering, or
 - has expired.
10. A fifth wheel or ball type coupling is installed to the front of a semi-trailer (**Note 7**).

Condition and performance (Note 3)

11. A coupling or its mounting:
- is not securely attached, or
 - bolt or nut is missing, significantly corroded or not suitable, or
 - is cracked, distorted or significantly deteriorated, or
 - has corrosion damage within 150 mm of the mounting points, or
 - pivot is seized, worn beyond manufacturer's specifications, or not securely attached.

Reasons for rejection

12. The fifth wheel release mechanism:
 - a) is not in good condition, eg the handle is bent or damaged, or
 - b) does not operate freely (check only if presented without trailer attached).
13. The fifth wheel locking mechanism:
 - a) is not in good condition, eg jaws are worn beyond manufacturer's specifications or out of adjustment, or
 - b) does not operate freely (check only if presented without trailer attached).

Modification and repair (Note 4)

14. A modification or repair affects the coupling and:
 - a) is not excluded from the requirements for HVS certification (**Table 8-6-1**), or
 - b) is not for the purpose of law enforcement or the provision of emergency services, or
 - c) is missing proof of HVS certification, ie:
 - i. the vehicle was modified or repaired before the last CoF inspection and no LANDATA record has been entered, or
 - ii. the vehicle was modified or repaired since the last CoF inspection and no valid LT400 form from an HVS certifier of category HVET, HVMT or HVIT has been presented.

Towing connections

8-6 Heavy vehicle fifth wheel or ball coupling (for towing a semi-trailer) (cont.)

Table 8-6-1. Requirements for HVS certification

HVS certification is required	HVS certification is not required
<ol style="list-style-type: none"> 1. Fitting of a coupling, other than a direct bolt-on replacement. 2. Modification or repair of a coupling. 	<ol style="list-style-type: none"> 1. Fifth wheel or ball-type coupling that is a direct bolt-on replacement. 2. Any modification or repair likely to have been carried out before 1 January 1997 (modifications and repairs before this date generally required certification but for inspection purposes the LANDATA record need not be checked). 3. Any repair or modification not listed in the left-hand column unless the vehicle inspector considers that certification is required because the modification or repair has affected the vehicle's safety performance (a second opinion from an expert may be needed, eg the manufacturer's representative, or a reputable workshop).

Table 8-6-2. Minimum information on certification label/plate

NZS 5446: 1987	NZS 5446: 2007
Company or agency name	Person, company or agency name
Certifying engineer	Certifier ID
VIN/Chassis number	Compliance certificate number (LT400)
Maximum towed mass (kg)	VIN/Chassis number
Expiry date (if certified on or after 1 August 1991)	Maximum towed mass
	Permitted static vertical load
	Coupling D value (minimum)
	Expiry date
	NZS 5446

Note 1 AS/NZS 4968 supersedes AS 1773 and AS 1771.

Note 2 Where the service history is incomplete, the CoF inspector must note this on the CoF checksheet, but the vehicle is not required to be failed for this reason alone.

Note 3 Where a vehicle is presented in combination, the vehicles do not have to be separated, but a thorough visual inspection as far as practicable must be carried out.

Note 4 A towing connection that was certified to New Zealand Standard 5446: 1987 (superseded) before November 2007 may continue to comply with and be certified to that standard until the towing connection is modified.

Note 5 While not included as an inspection item, a vehicle may not be towed using a fifth wheel coupled to another fifth wheel.

Note 6 Fifth wheel means a device fitted to a vehicle to enable a semi-trailer to be connected to it by means of a kingpin so that the semi-trailer may be towed.

Coupling means that part of a vehicle that is specifically designed to enable it to be connected to another vehicle; it does not include a structural member of the towing or towed vehicle (eg fifth wheel, hook, pin, ball or socket type).

Dedicated combination means a combination of vehicles certified for use in combination where both vehicles are affixed with a plate clearly and indelibly marked with the VIN or chassis number of the other vehicle (the plate is affixed by the HVS certifying engineer).

Semi-trailer means a trailer with only one axle set that is partially superimposed on the towing vehicle so that a substantial part of the trailer and its load is borne by the towing vehicle.

Note 7 Some car transporters are fitted with an inverted and front-to-back fifth wheel and kingpin combination. This is permitted. Please refer to the appropriate towing connection sections for the relevant inspection requirements.

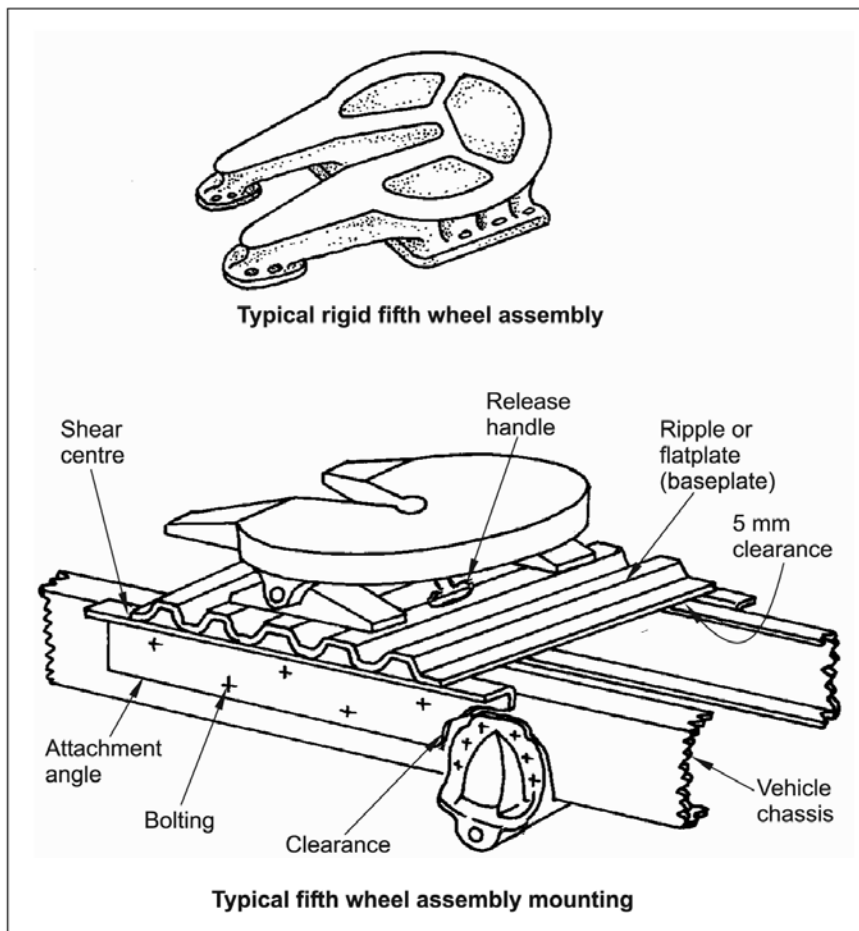



Figure 8-6-1. Fifth wheels

Towing connections

8-6 Heavy vehicle fifth wheel or ball coupling (for towing a semi-trailer) (cont.)



NZ TRANSPORT AGENCY
WAKA KOTAHI

Operator Statement of Compliance with the Maintenance Requirements of NZS 5450:1989

Operator to complete

Operators must choose to maintain the fifth wheel assembly on their vehicle(s) in accordance with either section 7.1 which is the coupling manufacturer's recommendations, or with sections 7.2 and 7.3, which are the recommendations of NZS 5450 (See extract from this standard on the inside front cover)

Statement number *(operator should allocate a number)*

Vehicle Make	Vehicle Model
<input style="width: 95%;" type="text"/>	<input style="width: 95%;" type="text"/>
Vehicle Registration Number	Vehicle Chassis/VIN Number
<input style="width: 95%;" type="text"/>	<input style="width: 95%;" type="text"/>
Fifth Wheel Make	Fifth Wheel Model
<input style="width: 95%;" type="text"/>	<input style="width: 95%;" type="text"/>

Fifth wheel assembly is being maintained to: *(tick one)*

Standard as recommended in sections 7.2 and 7.3 of NZS 5450.

Manufacturer's recommendations

→ Manufacturer's recommended service interval

→ Brief description of the manufacturer's recommendations

Six month service history

Show service inspections carried out on the fifth wheel assembly in the last 6 months.

Date	Hubodometer reading	Service inspection carried out by: <i>(Name of Service Company)</i>
/ /	<input style="width: 95%;" type="text"/>	<input style="width: 95%;" type="text"/>
/ /	<input style="width: 95%;" type="text"/>	<input style="width: 95%;" type="text"/>
/ /	<input style="width: 95%;" type="text"/>	<input style="width: 95%;" type="text"/>
/ /	<input style="width: 95%;" type="text"/>	<input style="width: 95%;" type="text"/>
/ /	<input style="width: 95%;" type="text"/>	<input style="width: 95%;" type="text"/>
/ /	<input style="width: 95%;" type="text"/>	<input style="width: 95%;" type="text"/>
/ /	<input style="width: 95%;" type="text"/>	<input style="width: 95%;" type="text"/>

Service Technician to complete

Last service inspection carried out by:

Name of Technician	Technician's Signature
<input style="width: 95%;" type="text"/>	<input style="width: 95%;" type="text"/>
Name of Service Company	
<input style="width: 95%;" type="text"/>	

Operator's Declaration

Print full name

I,

who have management responsibility for the maintenance of the above vehicle, affirm that the vehicle's fifth wheel coupling assembly has been maintained in compliance with section 7.1 or sections 7.2 and 7.3 of NZS 5450: 1989 Coupling Devices for Articulated Vehicles - Fifth Wheel Assemblies.

Signature	Date
<input style="width: 95%;" type="text"/>	<input style="width: 95%;" type="text"/>

New Zealand Government

Testing Station Copy

4085A-42651 10/08

Figure 8-6-2. 4085A form

Towing connections

8-7 Heavy vehicle kingpin or socket coupling (for towing a semi-trailer)

Summary of legislation

Applicable legislation

- Land Transport Rule: Heavy Vehicles 2004
- New Zealand Standard 5451: 1989, Coupling Devices for Articulated Vehicles – Fifth Wheel Kingpins
- Australian Standard 2175: 1995, Articulated Vehicles – Kingpins
- Australian/New Zealand Standard 4968: 2003, Heavy Road Vehicles – Mechanical Coupling between Articulated Vehicle Combinations., Parts 1-3 (supersedes AS 2175).
- Australian Standard 2174:1994, Articulated Vehicles – Mechanical Coupling between Prime Movers and Semi-Trailers – Interchangeability Requirements
- Australian Standard 4235: 1994, Articulated Vehicles – Design Criteria for Fifth Wheel Skid Plates
- New Zealand Standard 5446: 1987, Code of Practice for Heavy Motor Vehicle Towing Connections: Drawbar Trailers
- New Zealand Standard 5446: 2007, Heavy Vehicle Towing Connections – Drawbeams and Drawbars

Mandatory equipment

1. A semi-trailer must be fitted with:
 - a) a 50 mm or 90 mm diameter kingpin, and a skid plate, or
 - b) a socket type coupling certified to NZS 5446 and operated as part of a dedicated combination.
2. A 50 mm diameter kingpin and associated skid plate fitted to a vehicle must comply with NZS 5451.
3. A 90 mm diameter kingpin fitted to a vehicle before 1 April 2005 must be certified by an HVS certifier.
4. A 90 mm diameter kingpin fitted to a vehicle on or after 1 April 2005 must comply with both:
 - a) AS/NZS 4968 (supersedes AS 2175), and
 - b) AS 2174.
5. A skid plate fitted to a vehicle on or after 1 April 2005 and before 29 December 2007 in connection with a 90-mm diameter kingpin must comply with AS 4235.
6. A skid plate fitted to a vehicle on or after 29 December 2007 in connection with a 90 mm diameter kingpin must comply with AS/NZS 4968.
7. A vehicle that is fitted with a 90 mm diameter kingpin must have clearly displayed in a position readily visible at the lower right-hand side of the front end of the vehicle '90 mm kingpin' where '90' must not be less than 100 mm high.
8. A socket-type coupling must have an effective locking device and a separate means of retaining this device in the locked position.

Reasons for rejection

Mandatory equipment

1. A semi-trailer is not fitted with:
 - a) a 50 mm or 90 mm diameter kingpin and a skid plate, or
 - b) a socket-type coupling.
2. A kingpin or socket-type coupling fitted to a heavy semi-trailer does not have evidence of certification (unless excepted in **Table 8-7-1**), ie:
 - a) the coupling was fitted before the last CoF inspection, and after 1 January 1997, and no LANDATA record has been entered, or

Note Before 1 January 1997 certification was required but for inspection purposes the LANDATA record need not be checked)
 - b) the coupling was fitted after the last CoF inspection and
 - i. a valid LT400 form has not been presented, or
 - ii. the HVS certifier was not of category HVET, HVIT or HVMT.
3. A 50 mm diameter kingpin and associated skid plate has not been certified to NZS 5451.
4. A 90 mm diameter kingpin and skid plate installed on or after 1 April 2005 has not been certified to both of the following standards:
 - a) AS/NZS 4968 (supersedes AS 2175 and AS4235), and
 - b) AS 2174.
5. A trailer that is fitted with a 90 mm diameter kingpin does not have '90 mm kingpin', where '90' is at least 100 mm high, clearly displayed in a position readily visible at the lower right-hand side of the front end of the trailer.
6. A vehicle is fitted with a socket-type coupling to tow a semi-trailer and:
 - a) is not certified to NZS 5446, or
 - b) does not have a valid certification label or plate attached to the vehicle as required in **Table 8-7-2**, or
 - c) is not part of a dedicated combination (**Note 1**).

Towing connections

8-7 Heavy vehicle kingpin or socket coupling (for towing a semi-trailer) (cont.)

Condition and performance

9. Towing connection components fitted to a vehicle must ensure that a secure connection can be maintained between the towing and towed vehicles under all conditions of loading and operations for which the vehicle was constructed.
10. A coupling fitted to a vehicle must not have any cracks that can be detected by means of visual inspection.
11. Locking of the coupling must be readily verifiable by visual inspection.

Modification and repair

12. A modification or repair that affects the coupling must be inspected and certified by an HVS certifier of category HVET, HVMT or HVIT, unless the vehicle:
 - a) is excluded from the requirement for HVS certification (**Table 8-7-1**), and
 - b) has been inspected in accordance with the requirements in this manual, including those for equipment, condition and performance.

Reasons for rejection

7. A required certification label or plate:
 - a) is not indelible, or
 - b) is illegible, or
 - c) is not complete, or
 - d) is not attached to the vehicle in an easily visible position, or
 - e) does not match the vehicle, or
 - f) has obvious signs of tampering, or
 - g) has expired.
8. A hook- or pin-type coupling does not have a locking device or a separate means of retaining this device in the locked position.
9. A kingpin or socket-type coupling has been installed to the rear of a towing vehicle (**Note 2**).

Condition and performance (Note 4)

10. A skid plate or skid-plate mounting:
 - a) is not securely attached, or
 - b) is cracked, distorted or has significantly deteriorated, or
 - c) has corrosion damage within 150 mm of the mounting points.
11. A coupling or its mounting:
 - a) is not securely attached, or
 - b) bolt or nut is missing, significantly corroded or not suitable, or
 - c) is cracked, distorted or significantly deteriorated, or
 - d) has corrosion damage within 150 mm of its mounting points, or
 - e) has been repaired, or
 - f) is excessively worn, ie there is excessive play.
12. Locking of the coupling is not readily verifiable by visual inspection.
13. A coupling locking device is in such condition that it is not effective.

Reasons for rejection

Modification and repair (Note 2)

14. A modification or repair affects the kingpin or skid plate, or socket-type coupling and:
- a) is not excluded from the requirements for HVS certification (**Table 8-7-1**), or
 - b) the modification is not for the purpose of law enforcement or the provision of emergency services, or
 - c) is missing proof of HVS certification, ie:
 - i. the vehicle was modified or repaired before the last CoF inspection, and after 1 January 1997, and no LANDATA record has been entered, or

Note Before 1 January 1997 certification was required but for inspection purposes the LANDATA record need not be checked
 - ii. the vehicle was modified or repaired since the last CoF inspection and no valid LT400 form from an HVS certifier of category HVET, HVMT or HVIT has been presented.

Note 1 Kingpin means a pin attached to the skid plate of a semi-trailer and used for connecting the semi-trailer to the fifth wheel of a towing vehicle.

Skid plate means the plate structure forming part of the semi-trailer that houses the kingpin and that mounts on the coupler plate to form the connection between the towing vehicle and the semi-trailer.

Semi-trailer means a trailer with only one axle set that is partially superimposed on the towing vehicle so that a substantial part of the trailer and its load is borne by the towing vehicle.

Towing connection means the combination of components that enables one vehicle to tow or be towed by another vehicle; it includes a towbar, drawbar, drawbeam and coupling.

Fifth wheel means a device fitted to a vehicle to enable a semi-trailer to be connected to it by means of a kingpin so that the semi-trailer may be towed.

Coupling means that part of a vehicle that is specifically designed to enable it to be connected to another vehicle; it does not include a structural member of the towing or towed vehicle (eg fifth wheel, hook, pin, ball or socket type).

Dedicated combination means a combination of vehicles certified for use in combination where both vehicles are affixed with a plate clearly and indelibly marked with the VIN or chassis number of the other vehicle (the plate is affixed by the HVS certifying engineer).

Note 2 A towing connection that was certified to New Zealand Standard 5446: 1987 (superceded) before November 2007 may continue to comply with and be certified to that standard until the towing connection is modified.

Note 3 Some car transporters are fitted with an inverted and front-to-back fifth wheel and kingpin combination. This is permitted. Please refer to the appropriate towing connection sections for the relevant inspection requirements.

Note 4 Where a vehicle is presented in combination, the vehicles do not have to be separated, but a thorough visual inspection as far as practicable must be carried out.

Note 5 While not included as an inspection item, a vehicle may not be towed using a fifth wheel coupled to another fifth wheel.

Towing connections **8-7 Heavy vehicle kingpin or socket coupling (for towing a semi-trailer) (cont.)**

Table 8-7-1. Requirements for HVS certification

HVS certification is required	HVS certification is not required
<ol style="list-style-type: none"> 1. Fitting of a coupling, other than a direct bolt-on replacement. 2. Modification or repair of a coupling. 	<ol style="list-style-type: none"> 1. Kingpin or socket type coupling that is a direct bolt on replacement. 2. Any modification or repair likely to have been carried out before 1 January 1997 (modifications and repairs before this date generally required certification but for inspection purposes the LANDATA record need not be checked). 3. Any repair or modification not listed in the left-hand column unless the vehicle inspection considers that certification is required because the modification or repair has affected the vehicle's safety performance (a second opinion from an expert may be needed, eg the manufacturer's representative, or a reputable workshop).

Table 8-7-2. Minimum information on certification label/plate

NZS 5446: 1987	NZS 5446: 2007
Company or agency name	Person, company or agency name
Certifying engineer	Certifier ID
VIN/Chassis number	Compliance certificate number (LT400)
Maximum towed mass (kg)	VIN/Chassis number
Expiry date (if certified on or after 1 August 1991)	Maximum towed mass
	Maximum static vertical load
	Coupling D value (minimum)
	Expiry date
	NZS 5446

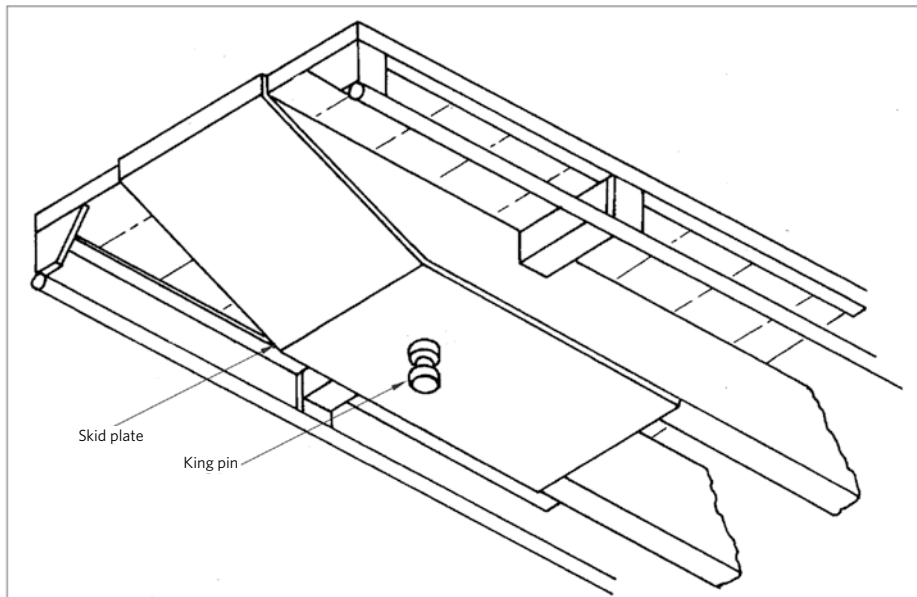

Figure 8-7-1. Kingpin and skid plate