

# Lighting

- 4-1 Headlamps
- 4-2 Front and rear fog lamps
- 4-3 Cornering lamps
- 4-4 Daytime running lamps
- 4-5 Direction indicator lamps
- 4-6 Forward-facing position lamps
- 4-7 Rearward-facing position lamps
- 4-8 Side-marker lamps
- 4-9 End-outline marker lamps
- 4-10 Stop lamps
- 4-11 High-mounted stop lamps
- 4-12 Rear-registration-plate illumination lamps
- 4-13 Rearward-facing retroreflectors
- 4-14 Reversing lamps
- 4-15 Cosmetic lamps



## Lighting

### 4-1 Headlamps

#### Summary of legislation

##### Applicable legislation

- Land Transport Rule: Vehicle Lighting 2004

##### Prohibited equipment

1. A trailer must not be fitted with a headlamp (**Note 1**).

#### Reasons for rejection

##### Prohibited equipment

1. A trailer is fitted with headlamps (**Note 1**).

**Note 1 Headlamp** means a lamp designed to illuminate the road ahead of a vehicle, and that is a:

- a) dipped-beam headlamp (single lamp), or
- b) main-beam (high-beam) headlamp (single lamp), and includes a driving lamp, or
- c) combination of a dipped-beam headlamp and a main-beam headlamp (dual-lamp unit).



## Lighting

## 4-2 Front and rear fog lamps

### Summary of legislation

#### Applicable legislation

- Land Transport Rule: Vehicle Lighting 2004

#### Permitted equipment

1. One or two rear fog lamps (**Note 1**).
2. A pair of lamps must be symmetrically mounted as far as is practicable towards each side of the vehicle.

#### Prohibited equipment

3. A trailer must not be fitted with front fog lamps.

#### Condition

4. A rear fog lamp must be in sound condition if it emits a light.
5. A rear fog lamp must not be obscured.

#### Performance

6. A rear fog lamp must operate in a way that is appropriate for the lamp and the vehicle.
7. A rear fog lamp must emit a steady light.
8. A rear fog lamp must provide sufficient light output to indicate the presence of the trailer on the road in conditions of severely reduced visibility.
9. The light emitted from a rear fog lamp must be diffused and substantially red in colour.
10. A pair of fog lamps must emit light that is approximately equal in colour and intensity.
11. A fog lamp must be able to be turned off from the driver's seating position.
12. Where a fog lamp comprises an array of light sources (eg LEDs), at least 75% of these must operate.

### Reasons for rejection

#### Permitted equipment

1. A trailer is fitted with:
  - a) a front fog lamp (**Note 1**), or
  - b) more than two rear fog lamps.
2. A pair of fog lamps is not fitted:
  - a) symmetrically, or
  - b) as far towards each side of the trailer as practicable.

#### Condition (**Note 2**)

3. A lamp is insecure, obscured or contains visible moisture or dirt.
4. A lens is missing, or has a hole, crack or other damage that allows moisture or dirt to enter.

#### Performance (**Note 2**)

5. When switched on, a rear fog lamp emits light that is:
  - a) not projected to the rear, or
  - b) not diffuse, or
  - c) not substantially red, or
  - d) different in colour or intensity from the other lamp in a pair, or
  - e) not steady, or
  - f) not bright enough to indicate the presence of the trailer from the rear in conditions of severely reduced visibility, eg due to modification, deterioration or an incorrect light source, or
  - g) altered, eg due to damage or modification.
6. A fog lamp cannot be switched off from the driver's seating position.
7. Where a fog lamp comprises an array of light sources (eg LEDs), fewer than 75% of these operate.

**Note 1 Fog lamp** means a front or rear lamp designed to aid the driver or other road users in conditions of severely reduced visibility, including fog or snow, but not including clear atmospheric conditions under the hours of darkness.

**Note 2** A rear fog lamp that does not comply with equipment, condition and performance requirements must be made to comply or be disabled so that it does not emit a light.



## Lighting

### 4-3 Cornering lamps

#### Summary of legislation

##### Applicable legislation

- Land Transport Rule: Vehicle Lighting 2004

##### Prohibited equipment

1. A trailer must not be fitted with cornering lamps (**Note 1**).

#### Reasons for rejection

##### Prohibited equipment

1. A trailer is fitted with cornering lamps (**Note 1**).

**Note 1** **Cornering lamp** means a lamp that is designed to emit light at the front of a vehicle to supplement the vehicle's headlamps by illuminating the road ahead in the direction of the turn.



## Lighting

### 4-4 Daytime running lamps

#### Summary of legislation

##### Applicable legislation

- Land Transport Rule: Vehicle Lighting 2004

##### Prohibited equipment

1. A trailer must not be fitted with daytime running lamps (**Note 1**).

#### Reasons for rejection

##### Prohibited equipment

1. A trailer is fitted with daytime running lamps (**Note 1**).

**Note 1 Daytime running lamp** means a lamp designed to emit a low-intensity light forward of a vehicle to make it more easily seen in the daytime.



## Lighting 4-5 Direction indicator lamps

### Summary of legislation

#### Applicable legislation

- Land Transport Rule: Vehicle Lighting 2004

#### Mandatory and permitted equipment

1. A trailer may be fitted with:
  - a) one or two pairs of lamps at the front, and
  - b) one or two pairs of lamps at the rear, and
  - c) one or two side-facing lamps at each side.
2. One or two pairs of lamps must be fitted to the rear of the trailer if the trailer is so constructed that it prevents an arm signal given by the driver from being seen from behind the vehicle combination.
3. A pair of lamps must be symmetrically mounted as far towards each side of the trailer as is practicable.
4. A lamp must be fitted at a height from the ground not exceeding 1.5 m, or if this is not possible due to the shape of the bodywork, not exceeding 2.1 m.
5. On trailers of American origin, the stop lamp and direction indicator lamp functions may be combined in one lamp.

#### Condition

6. A direction indicator lamp must:
  - a) be in sound condition, and
  - b) not be obscured.

#### Performance

7. A direction indicator lamp must operate in a way that is appropriate for the lamp and the vehicle.
8. A direction indicator lamp must emit a light that is substantially:
  - a) white or amber to the front, and
  - b) red or amber to the rear, and
  - c) amber to the side.
9. A lamp must flash at a fixed frequency in the range of 1-2 Hertz.
10. Each lamp in a pair must, when operated, emit a light of approximately equal intensity, colour and frequency.
11. A lamp must emit a light that is visible from 100 m during normal daylight and 200 m in normal darkness.
12. A retrofitted mandatory lamp must emit a light that is visible within angles of:
  - a) 15° above and below the horizontal, and
  - b) 45° inboard, and
  - c) 80° outboard.

### Reasons for rejection

#### Mandatory and permitted equipment

1. A trailer that is so constructed that the driver's arm signals cannot be seen from behind the trailer is not fitted with one pair of lamps at the rear.
2. A trailer is fitted with more than:
  - a) two pairs of lamps at the front, or
  - b) two pairs of lamps at the rear, or
  - c) two side-facing lamps on each side of the trailer.
3. A trailer is fitted with a lamp that is not in a pair.
4. A lamp is fitted at a height from the ground exceeding 1.5 m (or 2.1 m where fitting below 1.5 m is not practicable due to the shape of the bodywork of the trailer).
5. A pair of lamps is not:
  - a) symmetrically mounted, or
  - b) mounted as far towards each side of the trailer as practicable.

#### Condition

6. A lamp is insecure, obscured or contains visible moisture or dirt.
7. A lens is missing, or has a hole, crack or other damage that allows moisture or dirt to enter.
8. A reflector is damaged or has deteriorated so that light output is reduced.

#### Performance

9. When switched on, a direction indicator lamp:
  - a) does not operate, or
  - b) does not begin flashing within one second of switching on, or
  - c) flashes:
    - i. faster than two flashes per second, or
    - ii. slower than one flash per second, or
    - iii. at a different rate from other lamps on the same side.

## Lighting

### 4-5 Direction indicator lamps (cont.)

13. If a trailer of American origin is fitted with combined stop and indicator lamps, the indicator lamps must override the stop lamps so that the stop lamps operate as direction indicators.
14. Where a lamp comprises an array of light sources (eg LEDs), at least 75% of these must operate.

## Reasons for rejection

10. When switched on, a direction indicator lamp emits a light that is:
  - a) not substantially white or amber to the front, or
  - b) not substantially amber or red to the rear, or
  - c) not substantially amber to the side, or
  - d) different in colour or intensity from the other lamp in a pair, or
  - e) not bright enough to be visible from 100 m in normal daylight and from 200 m in normal darkness, eg due to modification, deterioration or an incorrect light source, or
  - f) too bright causing significant dazzle to other road users, eg due to an incorrect light source, or
  - g) altered, eg due to damage or modification.
11. A mandatory lamp emits a light that is not visible within (**Figure 4-5-1**):
  - a) 15° above and below the horizontal, or
  - b) 45° inboard and 80° outboard.
12. On a trailer of American origin fitted with combined stop and indicator lamps, the stop lamp function is not overridden by the indicator function.
13. Where a lamp comprises an array of light sources (eg LEDs), fewer than 75% of these operate.

**Note 1** **Direction indicator lamp** means a lamp designed to emit a flashing light to signal the intention of the driver to change the direction of the vehicle to the right or to the left.

**Note 2** A permitted (ie non-mandatory) rear- or side-facing direction indicator lamp that does not comply with condition and performance requirements must be made to comply or be disabled so that it does not emit a light.

**Note 3** A forward-facing permitted lamp that does not comply with the equipment, condition and performance requirements must be made to comply or be removed from the vehicle.

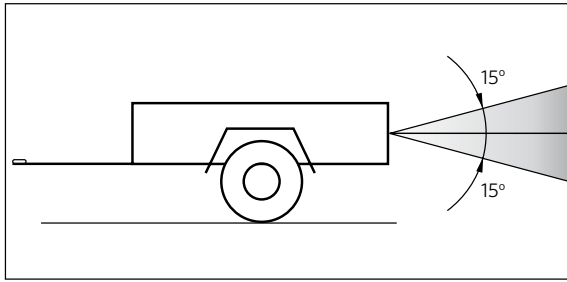

(a) Vertical beam angles

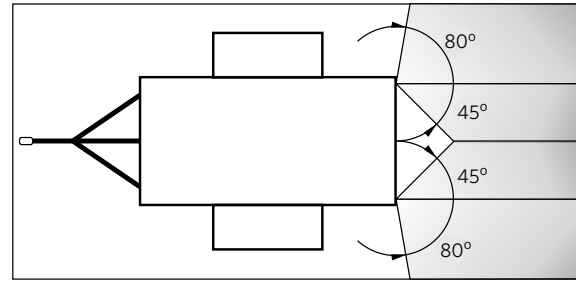

(b) Horizontal beam angles

Figure 4-5-1. Direction indicator beam angles



## Lighting 4-5 Direction indicator lamps

### Summary of legislation

#### Applicable legislation

- Land Transport Rule: Vehicle Lighting 2004

#### Permitted equipment

- A heavy trailer may be fitted with an additional pair of lamps at the rear of the vehicle that must be symmetrically mounted as near the top corners of the bodywork of the vehicle as is practicable (top-mounted lamps).
- Forward-facing or rearward-facing direction indicator lamps (excluding top-mounted lamps) may be mounted as follows:
  - one pair at a height from the ground not exceeding 1.5 m, or if this is not practicable due to the shape of the bodywork of the vehicle, not exceeding 2.1 m, and
  - a second pair at a height from the ground not exceeding 2.1 m.

#### Condition

- Refer to general trailer pages.

#### Performance

- Refer to general trailer pages.

#### Modifications

- Refer to general trailer pages.

### Reasons for rejection

#### Mandatory and permitted equipment

- Refer to general trailer pages.
- A heavy trailer is fitted at the rear with:
  - only one top-mounted lamp, or
  - more than one pair of top-mounted lamps, or
  - top-mounted lamps that are not mounted as close as is practicable to the top corners of the bodywork.
- A pair of forward-facing or rearward-facing direction indicator lamps (other than top-mounted lamps):
  - in the case of a vehicle with one pair, is fitted at a height from the ground exceeding 1.5 m (or 2.1 m where fitting below 1.5 m is not practicable due to the shape of the bodywork of the vehicle), or
  - in the case of a vehicle with two pairs:
    - the lower pair is fitted at a height from the ground exceeding 1.5 m (or 2.1 m where fitting below 1.5 m is not practicable due to the shape of the bodywork of the vehicle), or
    - the other pair is fitted at a height from the ground exceeding 2.1 m.
- A heavy trailer is fitted with top-mounted lamps at the front of the trailer.

#### Condition

- Refer to general trailer pages.

#### Performance

- Refer to general trailer pages.

**Note 1** **Direction indicator lamp** means a lamp designed to emit a flashing light to signal the intention of the driver to change the direction of the vehicle to the right or to the left.

**Modify** means to change a vehicle from its original state by altering, substituting, adding or removing a structure, system, component or equipment, but does not include repair.

**Repair** means to restore a damaged or worn vehicle, its structure, systems, components or equipment to within safe tolerance of its condition when manufactured, including replacement with undamaged or new structures, systems, components or equipment.

**Note 2** A forward-facing permitted lamp that does not comply with the equipment, condition and performance requirements must be made to comply or be removed from the vehicle.



**Lighting****4-6 Forward-facing position lamps****Summary of legislation****Applicable legislation**

- Land Transport Rule: Vehicle Lighting 2004

**Mandatory and permitted equipment**

1. A trailer more than 2 m wide must be fitted with one pair of forward-facing position lamps.
2. A trailer 2 m wide or less may be fitted with:
  - a) one forward-facing position lamp on the right side of the trailer, or
  - b) two forward-facing position lamps.
3. A lamp must be positioned to the front of the vehicle.

**Condition**

4. A forward-facing position lamp must:
  - a) be in sound condition, and
  - b) not be obscured.

**Performance**

5. A forward-facing position lamp must operate in a way that is appropriate for the lamp and the vehicle.
6. A lamp must emit a light that is:
  - a) diffuse, and
  - b) substantially white or amber, and
  - c) steady, and
  - d) sufficient to indicate to other road users the presence and dimensions of the trailer, and
  - e) of approximately equal intensity and colour to the other lamp in a pair.
7. A mandatory lamp must be visible within angles of:
  - a) 15° above and below the horizontal, and
  - b) 80° outboard.
8. Where a lamp comprises an array of light sources (eg LEDs), at least 75% of these must operate.

**Reasons for rejection****Mandatory and permitted equipment**

1. A trailer that is more than 2 m wide is not fitted with one pair of lamps.
2. A trailer is fitted with more than two lamps.
3. A trailer less than 2 m wide is fitted with a single lamp on the left side of the vehicle.
4. A pair of lamp is not s:
  - a) symmetrically mounted, or
  - b) mounted as far towards each side of the trailer as practicable.

**Condition**

5. A lamp is insecure, obscured or contains visible moisture or dirt.
6. A lens is missing, or has a hole, crack or other damage that allows moisture or dirt to enter.
7. A lamp's reflector is damaged or has deteriorated so that light output is reduced.

**Performance**

8. When switched on, a forward-facing position lamp does not operate.
9. When switched on, a forward-facing position lamp emits a light that is:
  - a) not substantially white or amber, or
  - b) not diffuse, or
  - c) not projected to the front, or
  - d) different in colour or intensity from the other lamp in a pair, or
  - e) not steady, or
  - f) not bright enough to be visible from 200 m in normal darkness, eg due to modification, deterioration or an incorrect light source.
10. A mandatory lamp emits a light that is not visible within (**Figure 4-6-1**):
  - a) 15° above and below the horizontal, or
  - b) 80° outboard.

## Lighting

## 4-6 Forward-facing position lamps (cont.)

### Reasons for rejection

11. Where a lamp comprises an array of light sources (eg LEDs), fewer than 75% of these operate.

**Note 1** Position lamp means a low-intensity lamp that is designed to indicate to road users the presence and dimensions of a vehicle, being:

- a) a forward-facing position lamp (front side lamp), or
- b) a rearward-facing position lamp (rear side lamp or tail lamp), or
- c) a side-marker lamp, or
- d) an end-outline marker lamp (including cab roof lamp).

**Note 2** A forward-facing permitted lamp that does not comply with the equipment, condition and performance requirements must be made to comply or be removed from the vehicle.

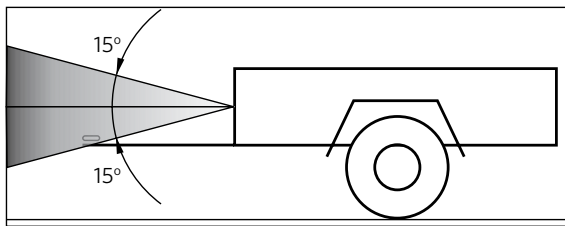

(a) Vertical beam angles

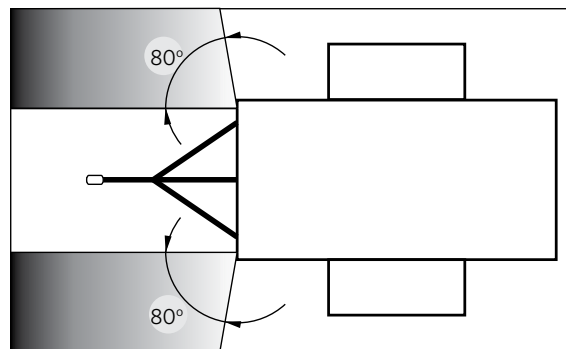

(b) Horizontal beam angles

Figure 4-6-1. Forward-facing position lamp beam angles

**Lighting****4-6 Forward-facing position lamps****Summary of legislation****Applicable legislation**

- Land Transport Rule: Vehicle Lighting 2004

**Permitted equipment**

1. A heavy trailer may be fitted with an additional pair of forward-facing position lamps that must be symmetrically mounted as near the top corners of the bodywork of the vehicle as is practicable (top-mounted lamps).

**Condition**

2. Refer to general trailer pages.

**Performance**

3. Refer to general trailer pages.

**Modifications**

4. Refer to general trailer pages.

**Reasons for rejection****Mandatory and permitted equipment**

1. Refer to general trailer pages.
2. A heavy trailer is fitted at the front with:
  - a) only one top-mounted lamp, or
  - b) more than one pair of top-mounted lamps, or
  - c) top-mounted lamps that are not mounted as close as is practicable to the top corners of the bodywork.

**Condition**

3. Refer to general trailer pages.

**Performance**

4. Refer to general trailer pages.

**Note 1** The following total numbers of position lamps may generally be fitted to the front or rear of a vehicle:

Front of vehicle:

- a) one pair of forward-facing position lamps below 1.5 m
- b) one pair of forward-facing position lamps at the top corners
- c) 10 end-outline marker lamps fitted elsewhere on the outline of the vehicle or on the cab roof (for vehicles first registered in New Zealand before 27 February 2005 there is no restriction on the number of forward-facing end-outline marker lamps that may be fitted).

Rear of vehicle:

- a) two pairs of rearward-facing position lamps, one pair below 1.5 m and a second pair below 2.1 m, fitted symmetrically as far as possible towards the extremities
- b) one pair of rearward-facing position lamps at the top corners
- c) six end-outline marker lamps elsewhere on the outline of the vehicle.



## Lighting

## 4-7 Rearward-facing position lamps

### Summary of legislation

#### Applicable legislation

- Land Transport Rule: Vehicle Lighting 2004

#### Mandatory and permitted equipment

1. A trailer first registered in New Zealand on or after 1 January 1978 and that is more than 1.5 m wide must be fitted with one or two pairs of rearward-facing position lamps (**Note 1**).
2. A trailer first registered in New Zealand before 1 January 1978 or that does not exceed 1.5 m in width must be fitted with:
  - a) one single rearward-facing position lamp in the centre or on the right side of the trailer, or
  - b) one or two pairs of rearward-facing position lamps.
3. A pair of lamps must be symmetrically mounted as far towards each side of the trailer as is practicable.
4. A lamp must be fitted at a height from the ground not exceeding 1.5 m, or if this is not practicable due to the shape of the bodywork of the trailer, not exceeding 2.1 m.

#### Condition

5. A rearward-facing position lamp must:
  - a) be in sound condition, and
  - b) not be obscured.

#### Performance

6. A rearward-facing position lamp must operate in a way that is appropriate for the lamp and the vehicle.
7. A lamp must emit a diffuse light that is substantially red.
8. A lamp must emit a steady light.
9. A lamp must provide sufficient light output to indicate to other road users the presence and dimensions of the trailer.
10. A lamp must emit light that is visible from a distance of 200 m in normal darkness.
11. A retrofitted mandatory lamp must be visible within angles of 15° above and below the horizontal, and within 45° inboard and 80° outboard.
12. Each lamp in a pair must, when operated, emit a light of approximately equal intensity and colour.
13. Where a lamp comprises an array of light sources (eg LEDs), at least 75% of these must operate.

### Reasons for rejection

#### Mandatory and permitted equipment

1. A trailer first registered in New Zealand before 1 January 1978 is not fitted with:
  - a) one single rearward-facing position lamp (**Note 1**) in the centre or to the right of the centre of the trailer, or
  - b) one pair of rearward-facing position lamps.
2. A trailer first registered in New Zealand on or after 1 January 1978:
  - a) that is less than 1.5 m wide is not fitted with one single rearward-facing position lamp in the centre or to the right of the centre of the trailer, or with one pair of rearward-facing position lamps, or
  - b) that is more than 1.5 m wide is not fitted with one pair of rearward-facing position lamps.
3. A trailer is fitted with more than:
  - a) one single lamp, or
  - b) two pairs of lamps.
4. A lamp is mounted at a height from the ground exceeding 1.5 m (or 2.1 m where fitting below 1.5 m is not practicable due to the shape of the bodywork of the trailer).
5. A pair of lamps is not:
  - a) symmetrically mounted, or
  - b) mounted as far towards each side of the trailer as is practicable.

#### Condition

6. A lamp is insecure, obscured or contains visible moisture or dirt.
7. A lens is missing, or has a hole, crack or other damage that allows moisture or dirt to enter.
8. A reflector is damaged or has deteriorated so that light output is reduced.

#### Performance

9. When switched on, a mandatory lamp does not operate.

**Lighting**

**4-7 Rearward-facing position lamps (cont.)**

**Reasons for rejection**

- 10. When switched on, a lamp emits a light that is:
  - a) not substantially red, or
  - b) not diffuse, or
  - c) not projected to the rear, or
  - d) different in colour or intensity from the other lamp in a pair, or
  - e) not steady, or
  - f) not bright enough to be visible from 200 m in normal darkness, eg due to modification, deterioration or an incorrect light source.
- 11. A mandatory lamp emits a light that is not visible within (**Figure 4-7-1**):
  - a) 15° above and below the horizontal, or
  - b) 45° inboard or 80° outboard
- 12. Where a lamp comprises an array of light sources (eg LEDs), fewer than 75% of these operate.

**Note 1 Position lamp** means a low-intensity lamp that is designed to indicate to road users the presence and dimensions of a vehicle, being:

- a) a forward-facing position lamp (front side lamp), or
- b) a rearward-facing position lamp (rear side lamp or tail lamp), or
- c) a side-marker lamp, or
- d) an end-outline marker lamp (including cab roof lamp).

**Note 2** A permitted (ie non-mandatory) rearward-facing position lamp that does not comply with equipment, condition and performance requirements must be made to comply or be disabled so that it does not emit a light.

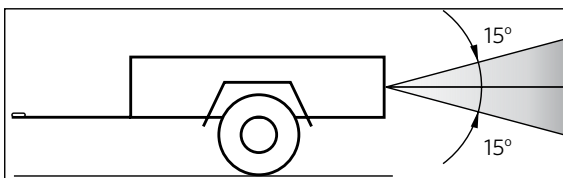

**(a) Vertical beam angles**

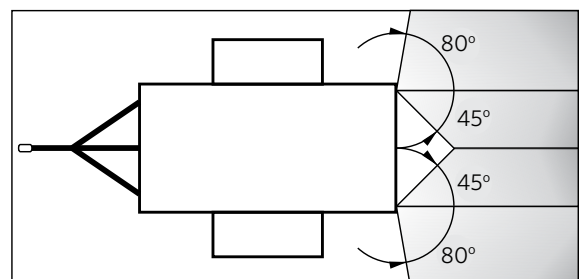

**(b) Horizontal beam angles**

**Figure 4-7-1. Rearward-facing position lamp beam angles**

## Lighting 4-7 Rearward-facing position lamps

### Summary of legislation

#### Applicable legislation

- Land Transport Rule: Vehicle Lighting 2004

#### Permitted equipment

1. A heavy trailer may be fitted with an additional pair of rearward-facing position lamps that must be symmetrically mounted as near the top corners of the bodywork of the vehicle as is practicable (top-mounted lamps).
2. Rearward-facing position lamps (excluding top-mounted lamps) may be mounted as follows:
  - a) one lamp or one pair at a height from the ground not exceeding 1.5 m, or if this is not practicable due to the shape of the bodywork of the vehicle, not exceeding 2.1 m, and
  - b) a second pair at a height from the ground not exceeding 2.1 m.

#### Condition

3. Refer to general trailer pages.

#### Performance

4. Refer to general trailer pages.

#### Modifications

5. Refer to general trailer pages.

### Reasons for rejection

#### Mandatory and permitted equipment

1. Refer to general trailer pages.
2. A heavy trailer is fitted at the rear with:
  - a) only one top-mounted lamp, or
  - b) more than one pair of top-mounted lamps, or
  - c) top-mounted lamps that are not mounted as close as is practicable to the top corners of the bodywork.
3. A rearward-facing position lamp (other than top-mounted lamps):
  - a) in the case of a vehicle with one or one pair, is fitted at a height from the ground exceeding 1.5 m (or 2.1 m where fitting below 1.5 m is not practicable due to the shape of the bodywork of the vehicle), or
  - b) in the case of a vehicle with two pairs:
    - i. the lower pair is fitted at a height from the ground exceeding 1.5 m (or 2.1 m where fitting below 1.5 m is not practicable due to the shape of the bodywork of the vehicle), or
    - ii. the other pair is fitted at a height from the ground exceeding 2.1m.

#### Condition

4. Refer to general trailer pages.

#### Performance

5. Refer to general trailer pages.



## Lighting

### 4-8 Side-marker lamps

#### Summary of legislation

##### Applicable legislation

- Land Transport Rule: Vehicle Lighting 2004

##### Permitted equipment

1. A light trailer may be fitted with side-marker lamps.
2. A side-marker lamp must be positioned so that it gives an indication of the vehicle's dimensions.

##### Condition

3. A side-marker lamp must be in sound condition.

##### Performance

4. A side-marker lamp must operate in a way that is appropriate for the lamp and the vehicle.
5. A lamp must emit a light that is:
  - a) diffuse, and
  - b) substantially white or amber to the front, and
  - c) substantially red or amber to the rear.
6. A lamp must emit a steady light.
7. A side-marker lamp must provide sufficient light output to indicate to other road users the presence and dimensions of the vehicle.
8. A side-marker lamp must emit a light that is visible:
  - a) from a distance of 100 m in daylight and 200 m during the hours of darkness, and
  - b) within an angle of 60° above and below a horizontal plane passing through the lamp, and within an angle of 60° forward and rearward of a vertical plane that is perpendicular to the longitudinal centreline of the vehicle and passing through the lamp.
9. Where a lamp comprises an array of light sources (eg LEDs), at least 75% of these must operate.

##### Modifications

10. A side-marker lamp that is affected by a modification must meet equipment, condition and performance requirements.

#### Reasons for rejection

##### Permitted equipment

1. A side-marker lamp is not positioned so that it gives an indication of the vehicle's dimensions.

##### Condition

2. A lamp is insecure or contains visible moisture or dirt.
3. A lens is missing, or has a hole, crack or other damage that allows moisture or dirt to enter.
4. A reflector is damaged or has deteriorated so that light output is reduced.

##### Performance

5. When switched on, a mandatory lamp does not operate.
6. When switched on, a side-marker lamp emits a light that:
  - a) is not substantially white or amber to the front, or
  - b) is not substantially red or amber to the rear, or
  - c) is not diffuse, or
  - d) is not approximately of the same colour and intensity on each side of the vehicle, or
  - e) does not remain steadily illuminated, or
  - f) is not bright enough to produce light that is visible from 100 m in normal daylight and from 200 m in normal darkness, eg due to modification, deterioration or an incorrect light source.
7. A side-marker lamp emits a light that is not visible within (**Figure 4-8-1**):
  - a) 60° above and below the horizontal, or
  - b) 60° forward and rearward.
8. Where a lamp comprises an array of light sources (eg LEDs), fewer than 75% of these operate.

## Lighting 4-8 Side-marker lamps (cont.)

### Note 1 Definitions

**Side-marker lamp** means a position lamp designed to be fitted to the side of a vehicle or its load.

**Position lamp** means a low-intensity lamp that is designed to indicate to road users the presence and dimensions of a vehicle, being:

- a) a forward-facing position lamp (front side lamp), or
- b) a rearward-facing position lamp (rear side lamp or tail lamp), or
- c) a side-marker lamp, or
- d) an end-outline marker lamp.

**Note 2** The position of a mandatory side-marker lamp need only be approximate as long as it indicates the vehicle's presence and approximate dimensions when viewed from the side.

**Note 3** A permitted side-marker lamp that does not comply with equipment, condition and performance requirements must be made to comply or be disabled so that it does not emit a light.

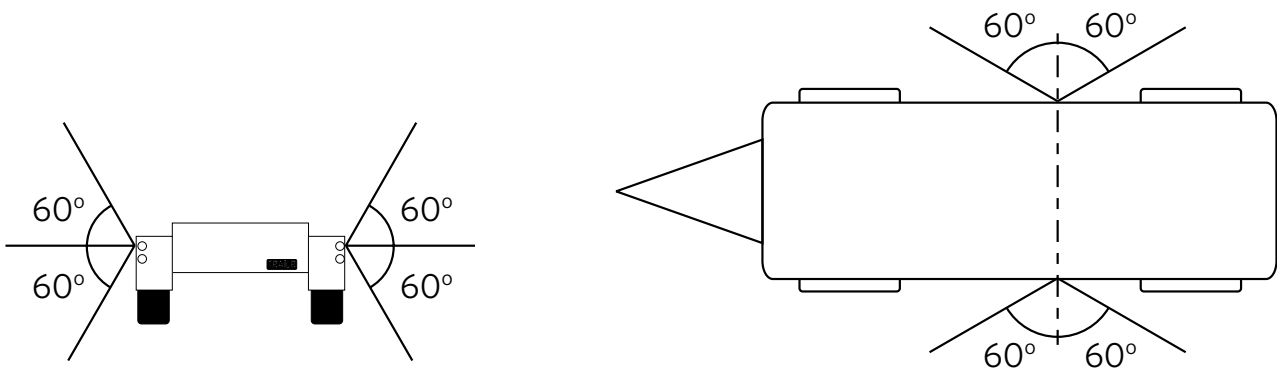

Figure 4-8-1. Visibility angles for side-marker lamps

## Lighting 4-8 Side-marker lamps

### Summary of legislation

#### Applicable legislation

- Land Transport Rule: Vehicle Lighting 2004

#### Mandatory and permitted equipment

1. A class TC or TD trailer fitted with two or more axles, or an articulated heavy vehicle that exceeds 9.2 m in length:
  - a) must be fitted on each side with one side-marker lamp at a point approximately one-third of the way along the vehicle measured from the rear, and
  - b) may be fitted with additional side-marker lamps.
2. A side-marker lamp must be positioned so that it gives an indication of the vehicle's dimensions.

#### Condition

3. A side-marker lamp must:
  - a) be in sound condition, and
  - b) not be obscured.

#### Performance

4. A side-marker lamp must operate in a way that is appropriate for the lamp and the vehicle.
5. A lamp must emit a light that is:
  - a) diffuse, and
  - b) substantially white or amber to the front, and
  - c) substantially red or amber to the rear.
6. A lamp must emit a steady light.
7. A side-marker lamp must provide sufficient light output to indicate to other road users the presence and dimensions of the vehicle.
8. A side-marker lamp must emit a light that is visible:
  - a) from a distance of 100 m in daylight and 200 m during the hours of darkness, and
  - b) within an angle of 60° above and below a horizontal plane passing through the lamp, and within an angle of 60° forward and rearward of a vertical plane that is perpendicular to the longitudinal centreline of the vehicle and passing through the lamp.
9. Where a lamp comprises an array of light sources (eg LEDs), at least 75% of these must operate.

#### Modifications

10. A side-marker lamp that is affected by a modification must meet equipment, condition and performance requirements.

### Reasons for rejection

#### Mandatory and permitted equipment

1. A class TC or TD trailer with two or more axles, or an articulated vehicle that exceeds 9.2 m in length, is not fitted on each side with a side-marker lamp at a point approximately one-third of the way along the vehicle, measured from the rear (**Note 2**).
2. A side-marker lamp is not positioned so that it gives an indication of the vehicle's dimensions.

#### Condition

3. A lamp is insecure, obscured or contains visible moisture or dirt.
4. A lens is missing, or has a hole, crack or other damage that allows moisture or dirt to enter.
5. A reflector is damaged or has deteriorated so that light output is reduced.

#### Performance

6. When switched on, a mandatory lamp does not operate.
7. When switched on, a side-marker lamp emits a light that:
  - a) is not substantially white or amber to the front, or
  - b) is not substantially red or amber to the rear, or
  - c) is not diffuse, or
  - d) is not approximately of the same colour and intensity on each side of the vehicle, or
  - e) does not remain steadily illuminated, or
  - f) is not bright enough to produce light that is visible from 100 m in normal daylight and from 200 m in normal darkness, eg due to modification, deterioration or an incorrect light source.
8. A side-marker lamp emits a light that is not visible within (**Figure 4-8-1**):
  - a) 60° above and below the horizontal, or
  - b) 60° forward and rearward.
9. Where a lamp comprises an array of light sources (eg LEDs), fewer than 75% of these operate.

## Lighting 4-8 Side-marker lamps (cont.)

### Note 1 Definitions

**Side-marker lamp** means a position lamp designed to be fitted to the side of a vehicle or its load.

**Position lamp** means a low-intensity lamp that is designed to indicate to road users the presence and dimensions of a vehicle, being:

- a) a forward-facing position lamp (front side lamp), or
- b) a rearward-facing position lamp (rear side lamp or tail lamp), or
- c) a side-marker lamp, or
- d) an end-outline marker lamp.

**Note 2** The position of a mandatory side-marker lamp need only be approximate as long as it indicates the vehicle's presence and approximate dimensions when viewed from the side.

**Note 3** A permitted side-marker lamp that does not comply with equipment, condition and performance requirements must be made to comply or be disabled so that it does not emit a light.

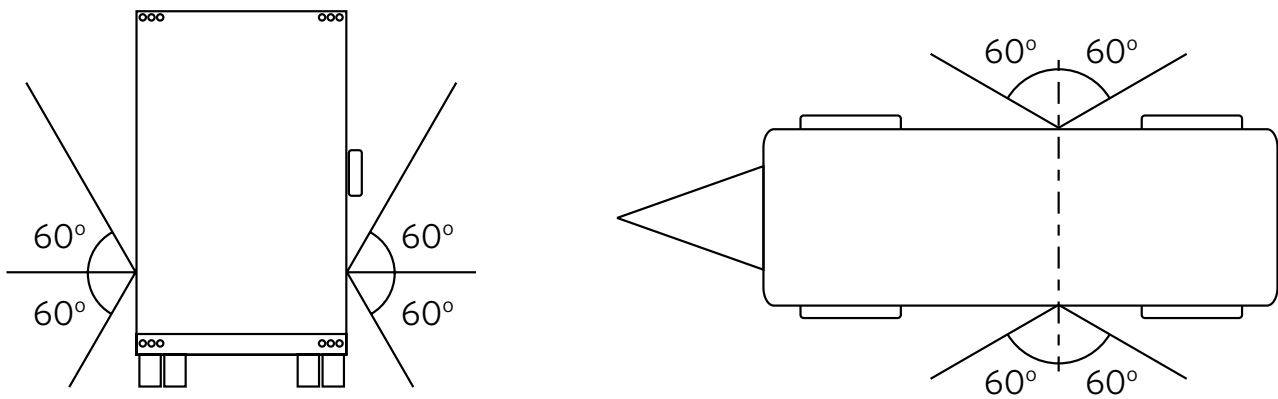

Figure 4-8-1. Visibility angles for side-marker lamps

## Lighting 4-9 End-outline marker lamps

### Summary of legislation

#### Applicable legislation

- Land Transport Rule: Vehicle Lighting 2004

#### Permitted and prohibited equipment

1. A light trailer with an overall width exceeding 1.8 m may be fitted with a maximum of:
  - a) four forward-facing lamps, and
  - b) two rearward-facing lamps.
2. A light trailer with an overall width of 1.8 m or less must not be fitted with end-outline marker lamps.
3. An end-outline marker lamp must be positioned so that it gives an indication of the vehicle's dimensions.

#### Condition

4. An end-outline marker lamp must be in sound condition.

#### Performance

5. An end-outline marker lamp must operate in a way that is appropriate for the lamp and the vehicle.
6. A lamp must emit a light that is:
  - a) diffuse, and
  - b) substantially white or amber to the front, and
  - c) substantially red to the rear.
7. A lamp must emit a steady light.
8. An end-outline marker lamp must provide sufficient light output to indicate to other road users the presence and dimensions of the vehicle.
9. Where a lamp comprises an array of light sources (eg LEDs), at least 75% of these must operate.

#### Modifications

10. An end-outline marker lamp that is affected by a modification must meet equipment, condition and performance requirements.

### Reasons for rejection

#### Permitted and prohibited equipment

1. A light trailer with an overall width exceeding 1.8 m is fitted with more than:
  - a) four forward-facing lamps, or
  - b) two rearward-facing lamps.
2. A light trailer with an overall width of 1.8m or less is fitted with end-outline marker lamps.
3. An end-outline marker lamp is not positioned so that it gives an indication of the vehicle's dimensions, ie lamps are fitted other than around the outline of the vehicle.

#### Condition

4. A lamp is insecure or contains visible moisture or dirt.
5. A lens is missing, or has a hole, crack or other damage that allows moisture or dirt to enter.
6. A reflector is damaged or has deteriorated so that light output is reduced.

#### Performance

7. When switched on, a forward-facing end-outline marker lamp does not operate.
8. When switched on, an end-outline marker lamp emits a light that is:
  - a) not substantially white or amber to the front, or
  - b) not substantially red to the rear, or
  - c) not diffuse, or
  - d) not projected to the front or rear, or
  - e) not approximately of the same colour and intensity as the other lamp if fitted in a pair, or
  - f) not steady, or
  - g) not bright enough to indicate the presence and dimensions of the vehicle to other road users.
9. Where a lamp comprises an array of light sources (eg LEDs), fewer than 75% of these operate.

## Lighting 4-9 End-outline marker lamps (cont.)

**Note 1** **End-outline marker lamp** means a position lamp designed to be fitted near the outer extremity of the vehicle in addition to forward-facing and rearward-facing position lamps, and includes a cab roof lamp.

**Position lamp** means a low-intensity lamp that is designed to indicate the presence and dimensions of a vehicle to other road users, being:

- a) a forward-facing position lamp (front side or park lamp), or
- b) a rearward-facing position lamp (rear side lamp or tail lamp), or
- c) a side-marker lamp, or
- d) an end-outline marker lamp (including cab roof lamps).

**Note 2** A forward-facing permitted lamp that does not comply with the equipment, condition and performance requirements must be made to comply or be removed from the vehicle. A rearward-facing end-outline marker lamp that does not comply with the equipment, condition and performance requirements must be made to comply or be disabled so that it does not emit a light.

## Lighting

## 4-9 End-outline marker lamps

## Summary of legislation

## Applicable legislation

- Land Transport Rule: Vehicle Lighting 2004

## Permitted and prohibited equipment

1. A trailer in **Table 4-9-1** must or may be fitted with end-outline marker lamps as specified in the table.
2. A trailer not listed in **Table 4-9-1** must not be fitted with end-outline marker lamps.
3. An end-outline marker lamp must be positioned so that it gives an indication of the vehicle's dimensions.

## Condition

4. An end-outline marker lamp must be in sound condition.

## Performance

5. An end-outline marker lamp must operate in a way that is appropriate for the lamp and the vehicle.
6. A lamp must emit a light that is:
  - a) diffuse, and
  - b) substantially white or amber to the front, and
  - c) substantially red to the rear.
7. A lamp must emit a steady light.
8. An end-outline marker lamp must provide sufficient light output to indicate to other road users the presence and dimensions of the vehicle.
9. Where a lamp comprises an array of light sources (eg LEDs), at least 75% of these must operate.

## Modifications

10. An end-outline marker lamp that is affected by a modification must meet equipment, condition and performance requirements.

## Reasons for rejection

## Permitted and prohibited equipment

1. A trailer listed in **Table 4-9-1** is fitted with lamps that exceed the numbers permitted in **Table 4-9-1**.
2. A trailer not listed in **Table 4-9-1** is fitted with end-outline marker lamps.
3. An end-outline marker lamp is not positioned so that it gives an indication of the vehicle's dimensions, ie lamps are fitted other than around the outline of the vehicle (**Note 2**).

## Condition

4. A lamp is insecure or contains visible moisture or dirt.
5. A lens is missing, or has a hole, crack or other damage that allows moisture or dirt to enter.
6. A reflector is damaged or has deteriorated so that light output is reduced.

## Performance

7. When switched on, a forward-facing end-outline marker lamp does not operate.
8. When switched on, an end-outline marker lamp emits a light that is:
  - a) not substantially white or amber to the front, or
  - b) not substantially red to the rear, or
  - c) not diffuse, or
  - d) not projected to the front or rear, or
  - e) not approximately of the same colour and intensity as the other lamp if fitted in a pair, or
  - f) not steady, or
  - g) not bright enough to indicate the presence and dimensions of the vehicle to other road users.
9. Where a lamp comprises an array of light sources (eg LEDs), fewer than 75% of these operate.

## Lighting 4-9 End-outline marker lamps (cont.)

**Table 4-9-1. Fitting requirements for end-outline marker lamps**

If the vehicle was:	Row	Characteristics of the heavy vehicle	Front	Rear
			Maximum permitted lamps <sup>1</sup>	Maximum permitted lamps <sup>1</sup>
Vehicle manufactured before 1/4/2011 <sup>2</sup>	A	<ul style="list-style-type: none"> <li>• A trailer with a GVM exceeding 11,300 kg</li> <li>• A trailer in a vehicle combination led by a heavy vehicle, where the combination's length exceeds 9.2 m</li> </ul>	12 (No Limit if first registered before 27/2/2005)	6
	B	A trailer with an overall width of 1.8 m or more (other than a trailer in row A)	6	4
Vehicle manufactured from 1/4/2011	C	A trailer with an overall width exceeding 2.1m <u>and</u> with a GVM or GCM exceeding 12,000kg	12	6
	D	A trailer with an overall width exceeding 2.1m (other than a trailer in row C)	6	4

<sup>1</sup> Maximum permitted lamps are the maximum number of lamps allowed to be fitted.

<sup>2</sup> A vehicle manufactured before 1/4/2011 also has the option of complying with the requirements applicable to vehicles manufactured from 1/4/2011.

**Note 1** For trailers manufactured before 1/5/2011, the following total numbers of position lamps may generally be fitted to the front or rear of a vehicle:

Front of vehicle:

- a) one pair of forward-facing position lamps below 1.5 m
- b) one pair of forward-facing position lamps at the top corners
- c) 10 end-outline marker lamps fitted elsewhere on the outline of the vehicle or on the cab roof (for vehicles first registered in New Zealand before 27 February 2005 there is no restriction on the number of forward-facing end-outline marker lamps that may be fitted).

Rear of vehicle:

- a) two pairs of rearward-facing position lamps, one pair below 1.5 m and a second pair below 2.1 m, fitted symmetrically as far as possible towards the extremities
- b) one pair of rearward-facing position lamps at the top corners
- c) six end-outline marker lamps elsewhere on the outline of the vehicle.

**Note 2 End-outline marker lamp** means a position lamp designed to be fitted near the outer extremity of the vehicle in addition to forward-facing and rearward-facing position lamps, and includes a cab roof lamp.

**Position lamp** means a low-intensity lamp that is designed to indicate the presence and dimensions of a vehicle to other road users, being:

- a) a forward-facing position lamp (front side or park lamp), or
- b) a rearward-facing position lamp (rear side lamp or tail lamp), or
- c) a side-marker lamp, or
- d) an end-outline marker lamp (including cab roof lamps).

**Note 3** A forward-facing permitted lamp that does not comply with the equipment, condition and performance requirements must be made to comply or be removed from the vehicle. A rearward-facing end-outline marker lamp that does not comply with the equipment, condition and performance requirements must be made to comply or be disabled so that it does not emit a light.

## Lighting 4-10 Stop lamps

### Summary of legislation

#### Applicable legislation

- Land Transport Rule: Vehicle Lighting 2004

#### Mandatory and permitted equipment

1. A trailer must be fitted at the rear with one or two pairs of stop lamps (**Note 1**) if its construction, equipment or loading prevents an arm signal given by the driver from being seen from behind the trailer.
2. A pair of stop lamps must be symmetrically mounted as far towards each side of the trailer as is practicable.
3. A stop lamp must be fitted at a height from the ground not exceeding 1.5 m, or if this is not practicable due to the shape of the bodywork of the trailer, not exceeding 2.1 m.

#### Condition

4. A stop lamp must:
  - a) be in sound condition, and
  - b) not be obscured.

#### Performance

5. A stop lamp must operate in a way that is appropriate for the lamp and the vehicle.
6. The light emitted from a stop lamp must be diffuse light that is substantially red.
7. A required stop lamp must operate when a service brake is activated.
8. A required stop lamp must provide sufficient light output to fulfil its intended purpose.
9. A stop lamp must emit a steady light.
10. A mandatory stop lamp must emit a light that is visible within the angles of 15° above and below the horizontal, and 45° inboard and outboard.
11. If a trailer of American origin is fitted with combined stop and direction indicator lamps, the indicator lamps must override the stop lamps so that the stop lamps will operate as direction indicators.
12. Where a stop lamp comprises an array of light sources (eg LEDs), at least 75% of these must operate.

### Reasons for rejection

#### Mandatory and permitted equipment

1. A trailer first registered in New Zealand on or after 1 January 1978:
  - a) is not fitted with one pair of stop lamps (**Note 1**) if the trailer is so constructed that the driver's arm signals or the towing vehicle's stop lamps cannot be seen from behind the trailer, or
  - b) is fitted with more than two pairs of stop lamps, or
  - c) is fitted with a stop lamp that is not in a pair.
2. A trailer first registered in New Zealand before 1 January 1978:
  - a) is not fitted with one stop lamp if the trailer is so constructed that the driver's arm signals or the towing vehicle's stop lamps cannot be seen from behind the trailer, or
  - b) is fitted with more than four stop lamps.
3. A stop lamp is fitted at a height from the ground exceeding 1.5 m (or 2.1 m where fitting below 1.5 m is not practicable due to the shape of the bodywork of the trailer).
4. A pair of lamps is not:
  - a) symmetrically mounted, or
  - b) mounted as far towards each side of the trailer as practicable.

#### Condition

5. A lamp is insecure, obscured or contains visible moisture or dirt.
6. A lens is missing, or has a hole, crack or other damage that allows moisture or dirt to enter.
7. A reflector is damaged or has deteriorated so that light output is reduced.

#### Performance

8. When the service brake is activated:
  - a) a mandatory lamp does not operate, or
  - b) a lamp does not remain steadily illuminated.

## Lighting 4-10 Stop lamps (cont.)

### Reasons for rejection

9. A lamp operates when the service brake is not activated.
10. A lamp emits a light that is:
  - a) not substantially red, or
  - b) not diffuse, or
  - c) not projected to the rear, or
  - d) different in intensity from the other lamp in a pair, or not bright enough to produce a light that is visible from 100 m in normal daylight, eg due to modification, deterioration or an incorrect light source.
11. A mandatory lamp emits a light that is not visible within **(Figure 4-10-1)**:
  - a) 15° above and below the horizontal, or
  - b) 45° inboard and outboard
12. Where a lamp comprises an array of light sources (eg LEDs), fewer than 75% of these operate.
13. On a trailer of American origin fitted with combined stop and direction indicator lamps, the stop lamp function is not overridden by the indicator function.

**Note 1** Stop lamp means a lamp that is designed to operate when the service brake is activated.

**Note 2** A permitted (ie non-mandatory) stop lamp that does not comply with equipment, condition and performance requirements must be made to comply or be disabled so that it does not emit a light.

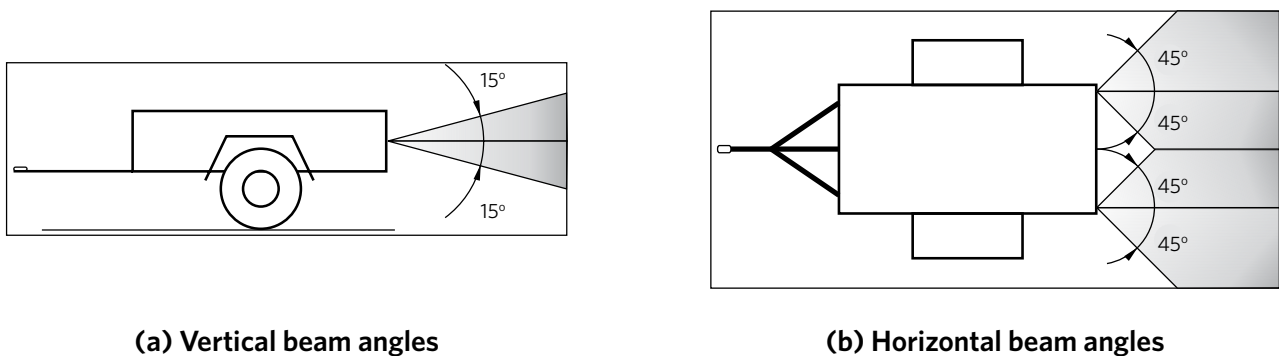

**Figure 4-10-1. Stop lamp beam angles**

## Lighting 4-10 Stop lamps

### Summary of legislation

#### Applicable legislation

- Land Transport Rule: Vehicle Lighting 2004

#### Permitted equipment

1. A heavy trailer may be fitted with an additional pair of stop lamps that must be symmetrically mounted as near the top corners of the bodywork of the vehicle as is practicable (top-mounted lamps).
2. Stop lamps (excluding top-mounted lamps) may be mounted as follows:
  - a) one lamp or one pair at a height from the ground not exceeding 1.5 m, if this is not practicable due to the shape of the bodywork of the vehicle, not exceeding 2.1 m, and
  - b) a second pair at a height from the ground not exceeding 2.1 m.

#### Condition

3. Refer to general trailer pages.

#### Performance

4. Refer to general trailer pages

#### Modifications

5. Refer to general trailer pages.

### Reasons for rejection

#### Mandatory and permitted equipment

1. Refer to general trailer pages.
2. A heavy trailer is fitted at the rear with:
  - a) only one top-mounted lamp, or
  - b) more than one pair of top-mounted lamps, or
  - c) top-mounted lamps that are not mounted as close as is practicable to the top corners of the bodywork.
3. A stop lamp (other than top-mounted lamps):
  - a) in the case of a vehicle with one or one pair, is fitted at a height from the ground exceeding 1.5 m (or 2.1 m where fitting below 1.5 m is not practicable due to the shape of the bodywork of the vehicle), or
  - b) in the case of a vehicle with two pairs:
    - i. the lower pair is fitted at a height from the ground exceeding 1.5 m (or 2.1 m where fitting below 1.5 m is not practicable due to the shape of the bodywork of the vehicle), or
    - ii. the other pair is fitted at a height from the ground exceeding 2.1 m.

#### Condition

4. Refer to general trailer pages.

#### Performance

5. Refer to general vehicle pages.

**Note 1** **Stop lamp** means a lamp that is designed to operate when the service brake is activated.

**Note 2** A permitted stop lamp that does not comply with equipment, condition and performance requirements must be made to comply or be disabled so that it does not emit a light.



## Lighting

### 4-11 High-mounted stop lamps

#### Summary of legislation

##### Applicable legislation

- Land Transport Rule: Vehicle Lighting 2004

##### Permitted equipment

1. A trailer may be fitted with one or two high-mounted stop lamps (**Note 1**).
2. A lamp must be fitted in a central high-mounted position at the rear of the trailer.

##### Condition

3. A high-mounted stop lamp must be in good condition.

##### Performance

4. A high-mounted stop lamp must operate in a way that is appropriate for the lamp and the vehicle.
5. The light emitted from a high-mounted stop lamp must be diffuse light that is substantially red.
6. A high-mounted stop lamp must emit a steady light.
7. Where a high-mounted stop lamp comprises an array of light sources (eg LEDs), at least 75% of these must operate.

#### Reasons for rejection

##### Permitted equipment

1. A trailer is fitted with more than two high-mounted stop lamps (**Note 1**).
2. A lamp is not fitted in a central high-mounted position.

##### Condition

3. A lamp is insecure, or contains visible moisture or dirt.
4. A lens is missing, or has a hole, crack or other damage that allows moisture or dirt to enter.
5. A reflector is damaged or has deteriorated so that light output is reduced.

##### Performance

6. When the service brake is activated, a lamp does not remain steadily illuminated.
7. A lamp operates when the service brake is not activated.
8. A lamp emits a light that:
  - a) is not substantially red, or
  - b) is not diffuse, or
  - c) is not projected to the rear, or
  - d) has insufficient light output to produce a light that is visible from 100 m in normal daylight, eg due to modification, deterioration or an incorrect light source.
9. Where a lamp comprises an array of light sources (eg LEDs), fewer than 75% of these operate.

**Note 1** **Stop lamp** means a lamp that is designed to operate when the service brake is activated.

**High-mounted stop lamp** means a stop lamp that is designed to be fitted in a central, high-mounted position at the rear of the vehicle.

**Note 2** A high-mounted stop lamp that does not comply with equipment, condition and performance requirements must be made to comply or be disabled so that it does not emit a light.



## Lighting

### 4-12 Rear-registration-plate illumination lamps

#### Summary of legislation

##### Applicable legislation

- Land Transport Rule: Vehicle Lighting 2004

##### Mandatory equipment

1. At least one rear-registration-plate illumination lamp (**Note 1**).

##### Performance

2. A rear-registration-plate illumination lamp must operate in a way that is appropriate for the lamp and the vehicle.
3. A lamp must emit a diffuse light that is substantially white.
4. A rear-registration-plate illumination lamp must emit a steady light.
5. The light source of the lamp must not be visible from the rear of the trailer.
6. A lamp must illuminate the figures and letters of the plate so that they are visible from 20 m during normal darkness.
7. Where a lamp comprises an array of light sources (eg LEDs), at least 75% of these must operate.

#### Reasons for rejection

##### Mandatory equipment

1. A trailer is not fitted with at least one rear-registration-plate illumination lamp (**Note 1**).

##### Performance

2. The lamp emits a light that is not:
  - a) substantially white, or
  - b) steady, or
  - c) diffuse.
3. The lamps are not bright enough to show up the registration plate text from 20 m in normal darkness.
4. The light source of a lamp is visible from the rear of the trailer.

**Note 1** Rear-registration-plate illumination lamp means a lamp designed to illuminate the rear registration plate of a vehicle.



## Lighting 4-13 Rear reflectors

### Summary of legislation

#### Applicable legislation

- Land Transport Rule: Vehicle Lighting 2004

#### Mandatory and permitted equipment

1. A trailer must be fitted with at least one pair of rearward-facing reflectors (**Note 1**) at a height from the ground not exceeding 1.5 m, or if this is not practicable due to the shape of the bodywork of the trailer, not exceeding 2.1 m.
2. A trailer equipped with a jinker pole that extends behind its rear lamps must also be fitted with one red reflector at the rear extremity of the pole.
3. A rearward-facing reflector must be positioned to the rear of the trailer.
4. A reflector must be of an area that allows it to reflect light to improve the visibility of the trailer to other road users without causing undue dazzle or discomfort.
5. A pair of reflectors must be symmetrically mounted as far towards each side of the trailer as is practicable.

#### Condition

6. A reflector must be in good condition.

#### Performance

7. A reflector must operate in a way that is appropriate for the reflector and the vehicle.
8. A reflector must reflect white light as substantially red light.
9. A reflector must provide sufficient light reflection to fulfil its intended purpose.

### Reasons for rejection

#### Mandatory and permitted equipment

1. A trailer:
  - a) is not fitted with at least one red rearward-facing reflector on each side (**Note 1**), or
  - b) is fitted with a red rearward-facing reflector that is not in a pair.
2. A reflector is not positioned to the rear of the trailer.
3. A reflector is fitted at a height from the ground exceeding 1.5 m, or if this is not practicable due to the shape of the bodywork of the trailer, exceeding 2.1 m.
4. A trailer equipped with a jinker pole that extends behind its rear lamps is not fitted with one red rearward-facing reflector at the rear extremity of the pole.
5. A pair of reflectors is not:
  - a) symmetrically mounted, or
  - b) mounted as far towards each side of the trailer as is practicable.

#### Condition

6. A mandatory reflector's ability to reflect light is affected by excessive:
  - a) fading, or
  - b) scratching or other damage.

#### Performance

7. The reflected light from a mandatory reflector is not visible from 100 m.
8. The reflected light from a reflector is not red.

**Note 1 Reflector** means a distinct item of lighting equipment that is designed to reflect incident light back towards the light source, but does not include reflective material (such as reflective tape).

**Reflective material** means any material that is designed to reflect incident light back towards the light source, and includes reflective tape, but does not include a reflector.



**Lighting****4-13 Rear reflectors****Summary of legislation****Applicable legislation**

- Land Transport Rule: Vehicle Lighting 2004

**Mandatory equipment**

1. Refer to general trailer pages.
2. A rearward-facing reflector fitted to a class TC or TD vehicle must have an area of at least 30 cm<sup>2</sup> and be fitted within 150 mm of the right and left extremities of the vehicle.
3. A trailer equipped with a jinker pole that extends behind its rear lamps must, in addition to the normal rear reflectors, be fitted with one red rear reflector at the rear extremity of the pole.

**Condition**

4. Refer to general trailer pages.

**Performance**

5. Refer to general trailer pages.

**Reasons for rejection****Mandatory equipment**

1. Refer to general trailer pages.
2. A rearward-facing reflector fitted to a class TC or TD vehicle:
  - a) does not have an area of at least 30 cm<sup>2</sup>, or
  - b) is not fitted within 150 mm of the right and left extremities of the vehicle.
3. A trailer equipped with a jinker pole that extends behind its rear lamps is not, in addition to the normal rear reflectors, fitted with one red rear reflector at the rear extremity of the pole.

**Condition**

4. Refer to general trailer pages.

**Performance**

5. Refer to general trailer pages.

**Note 1 Jinker pole** means a telescoping or sliding pole that forms the drawbar to steer a pole trailer.

**Pole trailer** means a trailer that is attached to the towing vehicle by a telescoping or sliding pole and is designed to support a common load of logs, or a similar load, spanning between the trailer and the towing vehicle.



## Lighting 4-14 Reversing lamps

### Summary of legislation

#### Applicable legislation

- Land Transport Rule: Vehicle Lighting 2004

#### Permitted equipment

1. One or two reversing lamps fitted at the rear of the trailer (**Note 1**).
2. A pair of reversing lamps must be symmetrically mounted as far towards each side of the trailer as is practicable.

#### Condition

3. A reversing lamp must be in good condition.

#### Performance

4. A reversing lamp must operate in a way that is appropriate for the lamp and the vehicle.
5. A reversing lamp, when operated, must emit a diffuse light or a dipped beam of light that is substantially white.
6. A reversing lamp must emit a steady light.
7. A reversing lamp may operate only when the reverse gear is engaged or the headlamps are turned off.
8. Where a reversing lamp comprises an array of light sources (eg LEDs), at least 75% of these must operate.

### Reasons for rejection

#### Permitted equipment

1. A trailer is fitted with more than two reversing lamps at the rear of the trailer (**Note 1**).
2. A pair of reversing lamps is not:
  - a) symmetrically mounted, or
  - b) mounted as far towards each side of the trailer as practicable.

#### Condition

3. A lamp is insecure, obscured or contains visible moisture or dirt.
4. A lens is missing, or has a hole, crack or other damage that allows moisture or dirt to enter.
5. A reflector is damaged or has deteriorated so that light output is reduced.

#### Performance

6. A lamp controlled by gear engagement continues to display a light to the rear when the reverse gear is disengaged.
7. A lamp controlled by a manual switch continues to display a light to the rear while the headlamps are switched on.
8. When engaged, a lamp emits light that is not:
  - a) substantially white, or
  - b) steady, or
  - c) diffuse or a dipped beam.
9. Where a lamp comprises an array of light sources (eg LEDs), fewer than 75% of these operate.

**Note 1 Reversing lamp** means a lamp designed to illuminate the area behind the vehicle while it is reversing and to warn other road users that the vehicle is reversing or about to reverse.

**Note 2** A reversing lamp that does not comply with equipment, condition and performance requirements must be made to comply or be disabled so that it does not emit a light.



## Lighting 4-15 Cosmetic lamps

### Summary of legislation

#### Applicable legislation

- Land Transport Rule: Vehicle Lighting 2004

#### Permitted equipment

1. A vehicle may be fitted with one or more lamps not specified in **Table 4-15-1**, provided they are fitted so that light sources are not visible in those regions specified in **Figure 4-15-1**.
2. A lamp must be fitted in a fixed position on the vehicle and positioned so that no part of the light source is situated within 250 mm of a mandatory lamp.

#### Performance

3. A lamp must:
  - a) only emit light that is diffuse, and
  - b) not emit light that flashes or otherwise varies in intensity or colour, and
  - c) be fitted in a way, and be of a luminance that ensures that it does not dazzle, confuse or distract other road users, and
  - d) not emit a light that revolves, rotates or otherwise moves, and
  - e) not cause confusion as to the orientation of the vehicle, and
  - f) not emit a red light that is directly visible from the front of the vehicle, and
  - g) not emit a light other than red or amber if the light is directly visible from the rear of the vehicle.

### Reasons for rejection

#### Permitted equipment

1. A cosmetic lamp (ie one not listed in **Table 4-15-1**) that is fitted to a vehicle:
  - a) has a part of its light-emitting surface positioned within 250 mm of any mandatory lamp, or
  - b) is not mounted in a fixed position, or
  - c) is positioned so that its light-emitting surface is visible within the shaded areas in **Figure 4-15-1**.

#### Performance

2. When switched on, a cosmetic lamp with a light-emitting surface not visible within the shaded areas in **Figure 4-15-1** emits a light that:
  - a) is not diffuse, or
  - b) flashes or otherwise varies in intensity or colour, or
  - c) revolves, rotates or otherwise moves, or
  - d) is too bright and likely to dazzle other road users, or
  - e) is likely to cause confusion about the orientation of the vehicle, or
  - f) is red when seen directly from the front, or
  - g) is not red or amber when seen directly from the rear.

# Lighting

## 4-15 Cosmetic lamps (cont.)

**Table 4-15-1. Lamps that are not cosmetic lamps**

Lamps covered in the VIRM	Other lighting equipment not requiring inspection
Headlamps	Reflective material
Stop lamps	Interior lamps
High-mounted stop lamps	<i>Designed to illuminate the interior of the vehicle for the convenience of passengers</i>
Direction indicator lamps	Work lamps
Position lamps (includes side-marker lamps and end-outline marker lamps)	<i>White or amber high-intensity lamps that are not necessary for the operation of the vehicle but are designed to illuminate the area around the vehicle or the vehicle itself</i>
Rear-registration-plate illumination lamps	Scene lamps
Rear reflectors	<i>Work lamps designed to provide a fixed or movable beam of light to illuminate the area around the vehicle or the vehicle itself</i>
Fog lamps	Alley lamps
Daytime running lamps	<i>Work lamps designed primarily to provide a fixed or movable beam of light to the side of the vehicle it is fitted to</i>
Cornering lamps	Flashing or revolving beacons
Reversing lamps	Illuminated vehicle-mounted signs
PSV interior lamps	<i>Includes PSV destination signs, taxi signs, and variable message signs operated by enforcement officers, under a traffic management plan or permitted by other legislation</i>

**Note 1** A rear or side cosmetic lamp that does not comply with requirements for condition or performance must be made to comply, or be disabled so that it does not emit a light.

**Note 2** **Lamp** means a device designed to emit light, and includes an array of separate light sources that appear as a continuous illuminated surface.

**Cosmetic lamp** means any lamp that is not listed in **Table 4-15-1**.

**Note 3** A forward-facing cosmetic lamp that does not comply with the equipment, condition and performance requirements must be made to comply or be removed from the vehicle.

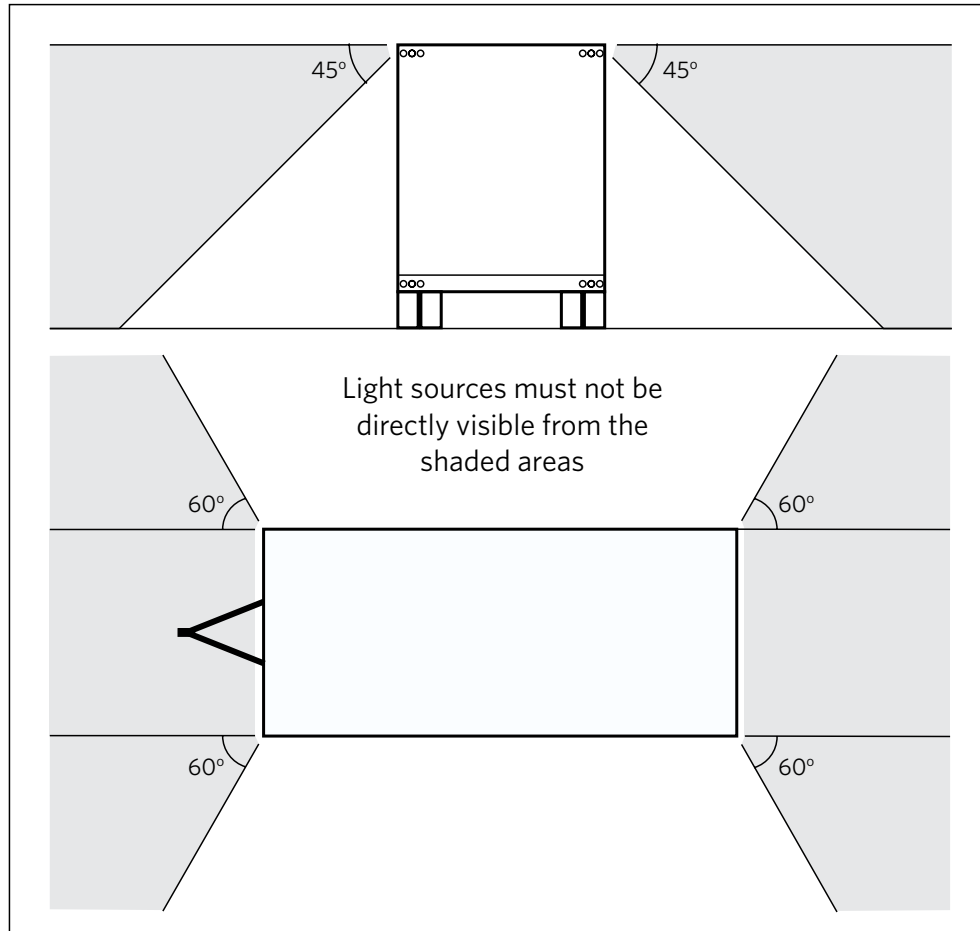

Figure 4-15-1. Visibility angles for cosmetic lamps

