

Lighting

- 4-1 Headlamps
- 4-2 Front and rear fog lamps
- 4-3 Cornering lamps
- 4-4 Daytime running lamps
- 4-5 Direction indicator lamps
- 4-6 Forward-facing position lamps
- 4-7 Rearward-facing position lamps
- 4-8 Side-marker lamps
- 4-9 End-outline marker lamps
- 4-10 Stop lamps
- 4-11 High-mounted stop lamps
- 4-12 Rear-registration-plate illumination lamps
- 4-13 Rear reflectors
- 4-14 Reversing lamps
- 4-15 Cosmetic lamps
- 4-16 PSV audible and visible reversing warning devices
- 4-17 PSV interior lighting

Lighting 4-1 Headlamps

Summary of legislation

Applicable legislation

- Land Transport Rule: Vehicle Lighting 2004
- *New Zealand Gazette*, 28 August 1980, issue 103, page 2569

Mandatory and permitted equipment

1. A vehicle other than of class LE:
 - a) must be fitted with one pair of dipped-beam headlamps, and
 - b) may be fitted with one or two pairs of main-beam headlamps.
2. A vehicle of class LE:
 - a) must be fitted with one or two dipped-beam headlamps, and
 - b) may be fitted with one or two main-beam headlamps.
3. A vehicle first registered anywhere between 1 February 1977 and 31 March 1980 may be fitted with a second pair of dipped-beam headlamps that:
 - a) do not operate when the main-beam headlamps are switched on, and
 - b) may operate independently of the first pair of dipped-beam headlamps.
4. A vehicle (eg a vintage or veteran vehicle) manufactured without lamps, or with lamps that cannot meet specified requirements, may obtain a WoF if:
 - a) the vehicle has a valid vehicle identity card with a lighting equipment endorsement, and
 - b) the vehicle meets the conditions of that endorsement.
5. A retrofitted dipped-beam headlamp on a vehicle with a GVM of 12,000 kg or less must be fitted at a height not exceeding 1.2 m from the ground (**Note 9**).
6. A warning device may be fitted that indicates that the main-beam headlamps are switched on.
7. An emergency vehicle or a pilot vehicle may be fitted with a device that allows the headlamps to flash alternately, provided it is also fitted with equipment that indicates to the driver that the device is activated.
8. A retrofitted pair of headlamps must be symmetrically mounted as far towards each side of the vehicle as is practicable.

Prohibited equipment

9. A dipped-beam headlamp designed solely for a left-hand drive vehicle, where the maximum intensity of the beam is dispersed to the right, must not be fitted.

Reasons for rejection

Mandatory and permitted equipment

1. A vehicle other than class LE is not fitted with one pair of dipped-beam headlamps.
2. A vehicle other than class LE is fitted with more than:
 - a) one pair of dipped-beam headlamps, or
 - b) two pairs of dipped-beam headlamps if the vehicle was first registered anywhere between 1 January 1977 and 31 March 1980, or
 - c) two pairs of main-beam headlamps.
3. A vehicle other than class LE is fitted with a headlamp that is not in a pair.
4. A vehicle of class LE is not fitted with one dipped-beam headlamp.
5. A vehicle of class LE is fitted with more than:
 - a) two dipped-beam headlamps, or
 - b) two main-beam headlamps.
6. A vehicle (eg a vintage or veteran vehicle) does not meet standard headlamp requirements, and:
 - a) does not have a valid vehicle identity card with a lighting equipment endorsement, or
 - b) does not meet the conditions of the lighting equipment endorsement in its vehicle identity card.
7. A retrofitted pair of headlamps is not fitted:
 - a) symmetrically, or
 - b) as far towards each side of the vehicle as is practicable.
8. A retrofitted dipped-beam headlamp on a vehicle with a GVM of 12,000 kg or less is positioned at a height exceeding 1.2 m from the ground (**Note 9**).
9. A device that allows the headlamps to flash alternately is fitted to a vehicle that is not an emergency vehicle or a pilot vehicle.
10. A vehicle is fitted with a dipped-beam headlamp where the maximum intensity of the beam is projected to the right.

Lighting 4-1 Headlamps (cont.)

Condition (Note 5)

10. A headlamp must:
 - a) be in sound condition, and
 - b) not be obscured.

Performance

11. A headlamp must operate in a way that is appropriate for the lamp and the vehicle.
12. A headlamp must emit a steady light.
13. A headlamp must provide sufficient illumination and light output to illuminate the road ahead.
14. If fitted with a device that allows headlamps to flash alternately, the lamps must flash at a fixed frequency.
15. A pair of headlamps must emit light that is approximately of equal colour and intensity when switched on.
16. A headlamp must emit a beam that is substantially white or amber.
17. A main-beam headlamp must be capable of being dipped or turned off from the driver's position.
18. A warning device that indicates that the main-beam lamps are in operation must be in good working order.
19. When the headlamps are switched on and the vehicle's front wheels are pointing in the straight-ahead position:
 - a) the centre of a headlamp beam must be either parallel to or to the left of the longitudinal centreline of the vehicle, and
 - b) the centre of a main-beam headlamp beam must be either parallel to or dipping down from the horizontal, and
 - c) the centre of a dipped-beam headlamp beam must dip at an angle specified by the vehicle or lamp manufacturer, or:
 - i. 3–3.5% for a symmetric beam pattern, or
 - ii. 1–1.5% for an asymmetric beam pattern where the centre of the light source is less than 0.8 m from the ground, or
 - iii. 1–2% for an asymmetric beam pattern where the centre of the light source is 0.8–1.2 m from the ground, or
 - iv. 2–2.5% for an asymmetric beam pattern where the centre of the light source is above 1.2 m from the ground.
20. The dipped-beam headlamps must illuminate the road ahead for 50 m in normal darkness.
21. A device fitted to a vehicle that allows the headlamps to flash must:
 - a) make the headlamps flash alternately at a frequency of 1–2 Hertz, and
 - b) incorporate equipment that indicates to the driver that the device is activated.

Reasons for rejection

Condition (Note 5)

11. A lamp is insecure, obscured, or contains visible moisture or dirt.
12. A lens is missing, or has a hole, crack or other damage that allows moisture or dirt to enter.
13. A reflector is damaged or has deteriorated so that light output is reduced.
14. A main-beam headlamp warning device is obscured from the driver's vision.

Performance

15. When switched on, a headlamp emits a light that is:
 - a) not substantially white or amber, or
 - b) different in colour or intensity from the other lamp in a pair, or
 - c) not steady, or
 - d) not bright enough to illuminate the road ahead, eg due to modification, deterioration or an incorrect light source, or
 - e) too bright, eg due to the fitment of an HID conversion kit (**Note 8**) or other incorrect light source.
16. When the dipped-beam headlamps are switched on (with wheels pointing straight ahead):
 - a) a lamp does not operate, or
 - b) more than two lamps operate on dipped beam, or
 - c) more than four lamps operate on dipped beam on a vehicle first registered anywhere between 1 January 1977 and 31 March 1980, or
 - d) the light beam produces an incorrect beam pattern, is not focused, or is reduced or altered, or
 - e) the centreline of the light beam is too far to the left or slopes down too far so that the headlamp is no longer capable of illuminating the road at least 50 m ahead (**Figure 4-1-1**), or
 - f) the centreline of the light beam projects to the right of the vehicle's centreline, or slopes down from the

22. A headlamp must be fitted with a light source that is specified by the vehicle manufacturer or the headlamp manufacturer.

Modifications (Note 4)

23. A headlamp that is affected by a modification must meet equipment, condition and performance requirements.

Reasons for rejection

lamp at an angle other than:

- i. as specified by the vehicle or lamp manufacturer, or
- ii. as specified in **Table 4-1-1**.

17. When the main-beam headlamps are switched on (with wheels pointing straight ahead):
- a) a lamp does not operate, or
 - b) more than two lamps operate on main beam on a class LE vehicle, or
 - c) more than four lamps operate on main beam on a vehicle of group M or N, or
 - d) a vehicle first registered anywhere between 1 February 1977 and 31 March 1980 has a second pair of dipped-beam headlamps that continue to operate, or
 - e) the centreline of the light beam projects to the right of the vehicle's centreline or up from the horizontal, or
 - f) the light beam produces an incorrect beam pattern, is not focused or is reduced or altered, or
 - g) the lamps are not capable of being switched to dipped beam or turned off from the driver's seating position, or
 - h) a main-beam headlamp warning device does not indicate to the driver that the main-beam headlamps are switched on.
18. A device fitted to a vehicle that allows the headlamps to flash alternately:
- a) does not indicate to the driver that the device is activated, or
 - b) flashes:
 - i. faster than two flashes per second, or
 - ii. slower than one flash per second, or
 - iii. at a varying frequency.

Lighting 4-1 Headlamps (cont.)

Table 4-1-1. Allowable dipped-beam headlamp alignment

	Headlamp type	Distance from ground to centre of light source	Dip rate of beam centre: lower and upper limits		
			Percent (%)	mm/3 m	Degrees (°)
EITHER	Any headlamp dipped beam	N/A	That specified by the vehicle or headlamp manufacturer		
OR	Headlamp with symmetric dipped-beam pattern	N/A	3.0-3.5	90-105	1.7-2.0
OR	Headlamp with asymmetric dipped-beam pattern and distance from ground to centre of light source	less than 0.8 m	1.0-1.5	30-45	0.57-0.85
		0.8-1.2 m	1.0-2.0	30-60	0.57-1.15
		more than 1.2 m	2.0-2.5	60-75	1.15-1.43

Table 4-1-2. Dipped-beam angle conversions

Percent (%)	mm/3 m	Degrees (°)	Percent (%)	mm/3 m	Degrees (°)
1.0	30	0.6	2.3	69	1.3
1.1	33	0.6	2.4	72	1.4
1.2	36	0.7	2.5	75	1.4
1.3	39	0.7	2.6	78	1.5
1.4	42	0.8	2.7	81	1.5
1.5	45	0.9	2.8	84	1.6
1.6	48	0.9	2.9	87	1.7
1.7	51	1.0	3.0	90	1.7
1.8	54	1.0	3.1	93	1.8
1.9	57	1.1	3.2	96	1.8
2.0	60	1.1	3.3	99	1.9
2.1	63	1.2	3.4	102	1.9
2.2	66	1.3	3.5	105	2.0

Note 1 An original equipment (OE) lamp is one that is fitted by the vehicle manufacturer in the original position, or is an equivalent replacement or aftermarket lamp suitable for the position provided by the vehicle manufacturer for that lamp. All other lamps are considered retrofitted (ie non-OE).

Note 2 If the dipped-beam headlamps are able to be adjusted from the driver's seating position, the alignment must be checked with the adjustment at its highest position.

Note 3 If the vehicle is fitted with self-levelling suspension, the alignment must be checked with the suspension at its normal level.

Note 4 Definitions

Modify means to change a vehicle from its original state by altering, substituting, adding or removing a structure, system, component or equipment, but does not include repair.

Repair means to restore a damaged or worn vehicle, its structure, systems, components or equipment to within safe tolerance of its condition when manufactured, including replacement with undamaged or new structures, systems, components or equipment.

Headlamp means a lamp designed to illuminate the road ahead of a vehicle, and that is a:

- a) dipped-beam headlamp (single lamp), or
- b) main-beam (high-beam) headlamp (single lamp), and includes a driving lamp, or
- c) combination of a dipped-beam headlamp and a main-beam headlamp (dual-lamp unit).

Dipped-beam headlamp means a headlamp that is designed to emit a dipped beam, which is a beam of light that is angled downwards in such a way that it prevents undue dazzle or discomfort to oncoming drivers and other road users.

Main-beam headlamp means a headlamp that is designed to illuminate the road over a long distance ahead of the vehicle.

Note 5 If a headlamp is fitted with a readily removable cover, other than a clear protective cover, this must be removed for inspection of the headlamp.

Note 6 A vehicle originally manufactured with a headlamp arrangement that differs from what is required or permitted in this section may retain the original headlamps provided they remain fitted in their original position and perform as intended by the vehicle manufacturer.

Note 7 A forward-facing permitted lamp that does not comply with the equipment, condition and performance requirements must be made to comply or be removed from the vehicle.

Note 8 A high-intensity discharge (HID or Xenon HID) conversion kit consists of an HID bulb with a high voltage power output or 'ballast' which fits into the original headlamp unit in place of the original bulb with no change to the headlamp lens, reflector or housing. It is illegal to fit an HID conversion kit to a vehicle as it brings the headlamp out of standards compliance by producing poor beam patterns and light that is far too bright to be safe. The bulbs can also produce light that is noticeably blue and not the required substantially white or amber colour. Vehicle and headlamp manufacturers do not permit this modification, and these kits cannot be LVV certified. It is permitted to replace a complete halogen headlamp unit with a complete HID headlamp unit.

Note 9 The dipped-beam headlamps may be positioned at a height exceeding 1.2 m if a road maintenance implement (eg, snowplough or roadsweeper) fitted to the front of the vehicle would obscure headlamps placed at a height of 1.2 m or less.

Lighting 4-1 Headlamps (cont.)

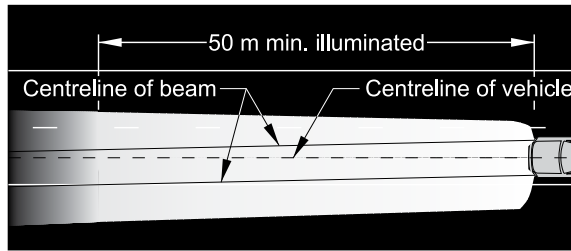

Figure 4-1-1. Minimum illuminated area

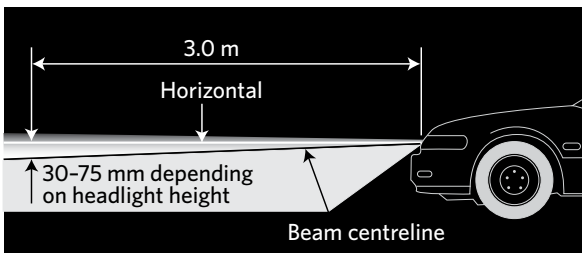

Figure 4-1-2. Asymmetric dipped beam

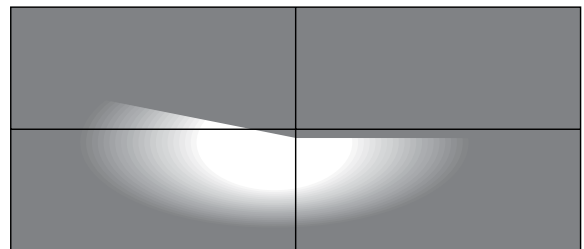

Figure 4-1-3. Asymmetric dipped beam headlamp pattern on light board

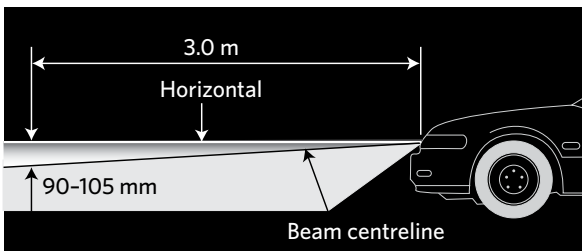

Figure 4-1-4. Symmetric dipped beam

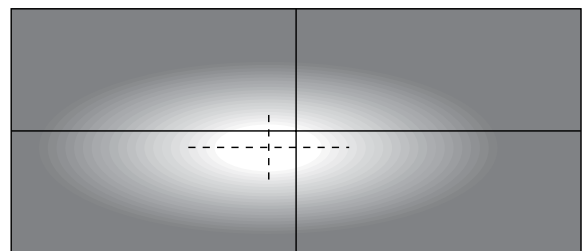

Figure 4-1-5. Symmetric dipped beam headlamp pattern on light board

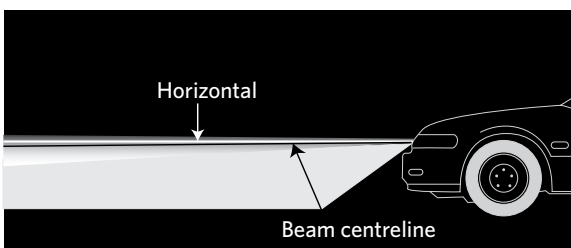

Figure 4-1-6. Main (high) beam

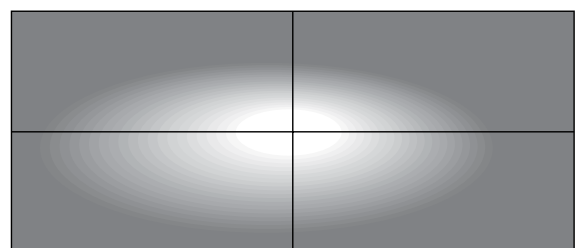

Figure 4-1-7. Main (high) beam headlamp pattern on light board

Lighting

4-2 Front and rear fog lamps

Summary of legislation

Applicable legislation

- Land Transport Rule: Vehicle Lighting 2004

Permitted equipment

- A vehicle other than class LE: one pair of front fog lamps.
- A vehicle of class LE: one or two front fog lamps.
- One or two rear fog lamps.
- A retrofitted pair of fog lamps must be symmetrically mounted as far as is practicable towards each side of the vehicle.
- A retrofitted front fog lamp must not be positioned higher than the dipped-beam headlamps.
- A vehicle may be fitted with a warning device that indicates that a front or rear fog lamp is in operation.

Condition

- A front fog lamp must be in sound condition.
- A rear fog lamp must be in sound condition if it emits a light.

Performance

- A fog lamp must operate in a way that is appropriate for the lamp and the vehicle.
- A fog lamp must emit a steady light.
- A front fog lamp must provide sufficient light output to illuminate the road ahead in conditions of severely reduced visibility.
- A rear fog lamp must provide sufficient light output to indicate the presence of the vehicle on the road in conditions of severely reduced visibility.
- The light emitted from a front fog lamp must be substantially white or amber.
- The light emitted from a rear fog lamp must be diffuse and substantially red in colour.
- A pair of fog lamps must emit light that is approximately equal in colour and intensity.
- The centre of a front fog lamp beam must be parallel to or to the left of the longitudinal centreline of the vehicle.
- The centre of a front fog lamp beam must be permanently dipped at an angle of at least 3%.
- A fog lamp must be able to be turned off from the driver's seating position.
- A front or rear fog lamp warning device must be in good working order.
- Where a fog lamp comprises an array of light sources (eg LEDs), at least 75% of these must operate.

Reasons for rejection

Permitted equipment

- A group M or N vehicle is fitted with:
 - only one front fog lamp, or
 - more than one pair of front fog lamps.
- A vehicle of class LE is fitted with more than two front fog lamps.
- A vehicle is fitted with more than two rear fog lamps.
- A retrofitted pair of fog lamps is not fitted:
 - symmetrically, or
 - as far towards each side of the vehicle as is practicable, or
 - positioned higher than the dipped-beam headlamps.

Condition (Note 3)

- A lamp is insecure or contains visible moisture or dirt.
- A lens is missing, or has a hole, crack or other damage that allows moisture or dirt to enter.
- A reflector is damaged or has deteriorated so that light output is reduced.
- A fog lamp warning device, if fitted, is obscured from the driver's vision.

Performance

- When switched on, a front fog lamp does not operate.
- When switched on, a front fog lamp emits light that:
 - is not projected to the front, or
 - produces an incorrect beam pattern (**Figure 4-2-1**), or
 - is not substantially white or amber to the front, or
 - is different in colour or intensity from the other lamp in the pair, or
 - is not steady, or
 - is not bright enough to illuminate the road ahead in conditions of severely reduced visibility, eg due to modification, deterioration or an incorrect light source, or

Lighting

4-2 Front and rear fog lamps (cont.)

Modifications

22. A fog lamp that is affected by a modification:

- a) must meet equipment, condition and performance requirements, and
- b) does not require LVV specialist certification.

Reasons for rejection

- g) is too bright, and could dazzle other road users, eg due to an incorrect light source, or
 - h) is altered, eg due to damage or modification, or
 - i) has a beam centre to the right of the vehicle's centreline, or
 - j) has a beam that is not permanently dipped, or
 - k) has a beam centre that dips at an angle of less than 3% (**Figure 4-2-1**).
11. When switched on, a rear fog lamp emits light that is:
- a) not projected to the rear, or
 - b) not diffuse, or
 - c) not substantially red, or
 - d) different in colour or intensity from the other lamp in a pair, or
 - e) of variable intensity, or
 - f) not bright enough to indicate the presence of the vehicle from the rear in conditions of severely reduced visibility, eg due to modification, deterioration or an incorrect light source, or
 - g) altered, eg due to damage or modification.
12. A fog lamp cannot be switched off from the driver's seating position.
13. Where a fog lamp comprises an array of light sources (eg LEDs), fewer than 75% of these operate.
14. A fog lamp warning device, if fitted, does not operate.

Note 1 Fog lamp means a high-intensity front or rear lamp designed to aid the driver or other road users in conditions of severely reduced visibility, including fog or snow, but not including clear atmospheric conditions under the hours of darkness.

Note 2 A rear fog lamp that does not comply with equipment, condition and performance requirements must be made to comply or be disabled so that it does not emit a light.

Note 3 If a front fog lamp is fitted with a readily removable cover, other than a clear protective cover, this must be removed for inspection of the fog lamp.

Note 4 A vehicle originally manufactured with a front- or rear-fog-lamp arrangement that differs from what is required or permitted in this section may retain the original front or rear fog lamps provided they remain fitted in their original position and perform as intended by the vehicle manufacturer.

Note 5 A forward-facing permitted lamp that does not comply with the equipment, condition and performance requirements must be made to comply or be removed from the vehicle

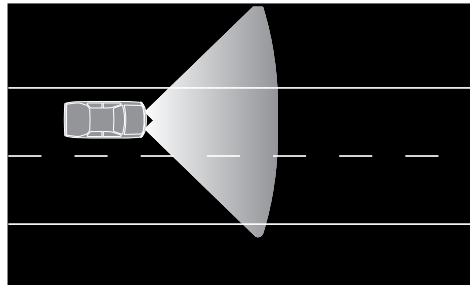

(a) Pattern on the road

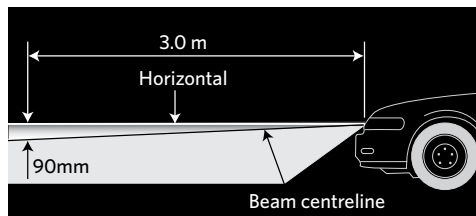

(b) Beam dip angle



(c) Pattern on light board

Figure 4-2-1. Front fog lamp characteristics

Lighting 4-3 Cornering lamps

Summary of legislation

Applicable legislation

- Land Transport Rule: Vehicle Lighting 2004

Permitted equipment

1. One pair of cornering lamps fitted as OE.

Condition

2. A cornering lamp must be in sound condition.

Performance

3. A cornering lamp must operate in a way that is appropriate for the lamp and the vehicle.
4. A cornering lamp must emit light that is substantially white or amber.
5. A pair of cornering lamps must emit light that is approximately equal in colour and intensity.
6. A cornering lamp must emit a steady light.
7. A cornering lamp must provide sufficient light output to illuminate the road ahead in the direction of the turn.
8. A cornering lamp must be correctly aligned.
9. Where a cornering lamp comprises an array of light sources (eg LEDs), at least 75% of these must operate.

Modifications

10. A cornering lamp that is affected by a modification:
 - a) must meet equipment, condition and performance requirements, and
 - b) does not require LVV specialist certification.

Reasons for rejection

Permitted equipment

1. A vehicle is fitted with:
 - a) only one lamp, or
 - b) more than one pair of lamps, or
 - c) a lamp that either:
 - i. was not originally fitted by the vehicle manufacturer, or
 - ii. is not fitted in the original position.

Condition

2. A lamp is insecure or contains visible moisture or dirt.
3. A lens is missing, or has a hole, crack or other damage that allows moisture or dirt to enter.
4. A lamp's reflector is damaged or has deteriorated so that light output is reduced.

Performance

5. When activated by switching on the direction indicator lamp or by turning the steering wheel, a cornering lamp:
 - a) does not operate, or
 - b) does not project in the direction of the turn.
6. A cornering lamp emits light that is:
 - a) not substantially white or amber, or
 - b) different in colour or intensity from the other lamp in the pair, or
 - c) not steady, or
 - d) not bright enough to illuminate the road ahead in the direction of the turn, eg due to modification, deterioration or an incorrect light source, or
 - e) too bright causing dazzle to other road users, eg due to an incorrect light source or misalignment, or
 - f) altered, eg due to damage or modification.
7. Where a cornering lamp comprises an array of light sources (eg LEDs), fewer than 75% of these operate.

Lighting

4-3 Cornering lamps (cont.)

- Note 1** **Cornering lamp** means a lamp designed to emit light at the front of a vehicle to supplement the vehicle's headlamps by illuminating the road ahead in the direction of the turn.
- Note 2** An original equipment (OE) lamp is one that is fitted by the vehicle manufacturer in the original position, or is an equivalent replacement or aftermarket lamp suitable for the position provided by the vehicle manufacturer for that lamp. All other lamps are considered retrofitted (ie non-OE).
- Note 3** A vehicle originally manufactured with a cornering lamp arrangement that differs from what is required or permitted in this section may retain the original cornering lamps provided they remain fitted in their original position and perform as intended by the vehicle manufacturer.
- Note 4** A forward-facing permitted lamp that does not comply with the equipment, condition and performance requirements must be made to comply or be removed from the vehicle.

Lighting

4-4 Daytime running lamps

Summary of legislation

Applicable legislation

- Land Transport Rule: Vehicle Lighting 2004

Permitted equipment

1. A vehicle other than class LE: one pair of daytime running lamps fitted to the front of the vehicle.
2. A vehicle of class LE: one or two daytime running lamps fitted to the front of the vehicle.

Condition

3. A daytime running lamp must be in sound condition.

Performance

4. A daytime running lamp must operate in a way that is appropriate for the lamp and the vehicle.
5. A daytime running lamp must emit light that is substantially white or amber.
6. A pair of daytime running lamps must emit light that is of approximately equal colour and intensity.
7. A daytime running lamp must emit a steady light.
8. A daytime running lamp must provide sufficient light output to make the vehicle more easily seen during the daytime.
9. A daytime running lamp must be correctly aligned.
10. A daytime running lamp must not operate when a front fog lamp or a headlamp is in use.
11. Where a daytime running lamp comprises an array of light sources (eg LEDs), at least 75% of these must operate.

Modifications

12. A daytime running lamp that is affected by a modification:
 - a) must meet equipment, condition and performance requirements, and
 - b) does not require LVV specialist certification.

Reasons for rejection

Permitted equipment

1. A vehicle other than class LE is fitted with:
 - a) only one lamp, or
 - b) more than one pair of lamps.
2. A vehicle of class LE is fitted with more than two lamps.
3. A lamp is fitted in a position other than at the front of the vehicle.
4. A retrofitted lamp is not:
 - a) symmetrically mounted, or
 - b) mounted as far towards each side of the vehicle as is practicable.

Condition

5. A lamp is insecure or contains visible moisture or dirt.
6. A lens is missing, or has a hole, crack or other damage that allows moisture or dirt to enter.
7. A lamp's reflector is damaged or has deteriorated so that light output is reduced.

Performance

8. When switched on, a daytime running lamp does not operate (**Note 4**).
9. When switched on, a daytime running lamp emits light that is:
 - a) projected in a direction other than to the front, or
 - b) not substantially white or amber, or
 - c) different in colour or intensity from the other lamp in the pair, or
 - d) not steady, or
 - e) not bright enough to make the vehicle more easily seen during the daytime, eg due to modification, deterioration or an incorrect light source, or
 - f) too bright, causing significant dazzle to other road users, eg due to an incorrect light source, or
 - g) altered, eg due to damage or modification.

Lighting

4-4 Daytime running lamps (cont.)

Reasons for rejection

10. Where a daytime running lamp comprises an array of light sources, fewer than 75% of these operate.
11. A daytime running lamp continues to operate when the headlamps or fog lamps are switched on.

Note 1 **Daytime running lamp** means a lamp designed to emit a low-intensity light forward of a vehicle to make it more easily seen in the daytime.

Note 2 A vehicle originally manufactured with a daytime running lamp arrangement that differs from what is required or permitted in this section may retain the original daytime running lamps provided they remain fitted in their original position and perform as intended by the vehicle manufacturer.

Note 3 A forward-facing permitted lamp that does not comply with the equipment, condition and performance requirements must be made to comply or be removed from the vehicle.

Note 4 Some vehicles are equipped with OE or after-market daytime running lamps (DRLs) that also incorporate position lamp and direction indicator lamp functions. When the DRLs are on (when headlamps are off), and an indicator lamp is activated, the corresponding DRL is temporarily extinguished or dimmed. When the position lamps are on and an indicator lamp is activated, the corresponding position lamp may remain lit.

Lighting**4-5 Direction indicator lamps****Summary of legislation****Applicable legislation**

- Land Transport Rule: Vehicle Lighting 2004

Mandatory and permitted equipment

1. A vehicle other than class LE first registered anywhere before 1 July 1967 may be fitted with one or two pairs of lamps to the front and one or two pairs of lamps to the rear of the vehicle.
2. A vehicle other than class LE first registered anywhere on or after 1 July 1967 must be fitted with one or two pairs of lamps to the front and one or two pairs of lamps to the rear of the vehicle.
3. A vehicle of class LE first registered in New Zealand before 1 January 1978 may be fitted with one pair of lamps to the front and one pair of lamps to the rear of the vehicle.
4. A vehicle of class LE first registered in New Zealand on or after 1 January 1978 must be fitted with one or two pairs of lamps to the front and one or two pairs of lamps to the rear of the vehicle.
5. An emergency vehicle may be fitted with an additional pair of indicator lamps at the rear of the vehicle that must be symmetrically mounted as near to the top corners of the bodywork of the vehicle as is practicable (top-mounted lamps).
6. A vehicle may be fitted with one or two side-facing lamps on each side.
7. A suitable device must be fitted that indicates to the driver the failure of a mandatory lamp.
8. A vehicle (eg a vintage or veteran vehicle) manufactured without lamps, or with lamps that cannot meet specified requirements, may obtain a WoF if:
 - a) the vehicle has a valid vehicle identity card with a lighting equipment endorsement, and
 - b) the vehicle meets the conditions of that endorsement.
9. A retrofitted pair of lamps, other than top-mounted lamps, must be mounted:
 - a) symmetrically as far towards each side of the vehicle as is practicable, and
 - b) at a height from the ground not exceeding 1.5 m, or if this is not practicable due to the shape of the bodywork of the vehicle, not exceeding 2.1 m.
10. On vehicles of American origin, the stop lamp and direction indicator lamp function may be combined in one lamp.

Condition

11. A direction indicator lamp must:
 - a) be in sound condition, and
 - b) not be obscured (if a mandatory lamp).

Reasons for rejection**Mandatory and permitted equipment**

1. A vehicle of class LE first registered in New Zealand on or after 1 January 1978 is not fitted with one pair of lamps to the front and one pair of lamps to the rear.
2. A vehicle of class LE first registered in New Zealand before 1 January 1978 is fitted with more than one pair of lamps to the front or more than one pair of lamps to the rear.
3. A vehicle other than class LE first registered anywhere on or after 1 July 1967 is not fitted with one pair of lamps to the front and one pair of lamps to the rear.
4. A vehicle is fitted with more than:
 - a) two pairs of lamps to the front, or
 - b) two pairs of lamps to the rear, or
 - c) three pairs of lamps (including top-mounted lamps) to the rear if the vehicle is an emergency vehicle.
5. An emergency vehicle is fitted at the rear with:
 - a) more than one pair of top-mounted lamps, or
 - b) top-mounted lamps that are not mounted as close as is practicable to the top corners of the bodywork.
6. A vehicle is fitted with more than two side-facing lamps on each side of the vehicle.
7. A vehicle is fitted with a lamp that is not in a pair.
8. A vehicle is not fitted with a visual lamp indicator device that indicates to the driver that a lamp has failed (only where one was fitted as original equipment).
9. A retrofitted lamp is not:
 - a) symmetrically mounted, or
 - b) mounted as far towards each side of the vehicle as is practicable.
10. A retrofitted lamp, other than a top-mounted lamp on an emergency vehicle, is fitted at a height from the ground exceeding 1.5 m (or 2.1 m where fitting below 1.5 m is not practicable due to the shape of the bodywork of the vehicle).

Lighting 4-5 Direction indicator lamps

Performance

12. A direction indicator lamp must operate in a way that is appropriate for the lamp and the vehicle.
13. A direction indicator lamp must emit a light that is substantially:
 - a) white or amber to the front, and
 - b) red or amber to the rear, and
 - c) amber to the side.
14. A lamp must flash at a fixed frequency in the range of 1-2 Hertz.
15. Each lamp in a pair must, when operated, emit a light of approximately equal intensity, colour and frequency.
16. The lamp-failure indicating device must function.
17. A lamp must emit a light that is visible from 100 m during normal daylight and 200 m in normal darkness.
18. A retrofitted mandatory lamp must emit a light that is visible within angles of
 - a) 15° above and below the horizontal, and
 - b) 45° inboard, and
 - c) 80° outboard.
19. If a vehicle of American origin is fitted with combined stop and indicator lamps, the indicator lamps must override the stop lamps so that the stop lamps operate as direction indicators.
20. Where a lamp comprises an array of light sources (eg LEDs), at least 75% of these must operate.

Modifications (Note 1)

21. A direction indicator lamp that is affected by a modification must meet equipment, condition and performance requirements.

Reasons for rejection

11. A vehicle (eg avintage or veteran vehicle) does not meet standard direction indicator lamp requirements, and:
 - a) does not have a valid vehicle identity card with a lighting equipment endorsement, or
 - b) does not meet the conditions of the lighting equipment endorsement in its vehicle identity card.

Condition

12. A lamp is insecure or contains visible moisture or dirt.
13. A lens is missing, or has a hole, crack or other damage that allows moisture or dirt to enter.
14. A lamp's reflector is damaged or has deteriorated so that light output is reduced.
15. A visual lamp-failure warning device is obscured from the driver in the driver's seating position.

Performance

16. When switched on, a direction indicator lamp:
 - a) does not operate, or
 - b) does not begin flashing within one second of switching on, or
 - c) flashes:
 - i. faster than two flashes per second, or
 - ii. slower than one flash per second, or
 - iii. at a different rate from other lamps on the same side.
17. When switched on, a direction indicator lamp emits a light that is:
 - a) not substantially white or amber to the front, or
 - b) not substantially amber or red to the rear, or
 - c) not substantially amber to the side, or
 - d) different in colour or intensity from the other lamp in a pair, or
 - e) not bright enough to be visible from 100 m in normal daylight and from 200 m in normal darkness, eg due to modification, deterioration or an incorrect light

Reasons for rejection

source, or

- f) too bright causing significant dazzle to other road users, eg due to an incorrect light source, or
- g) altered, eg due to damage or modification.

18. A non-OE mandatory lamp mounted outside the original position emits a light that is not visible within (Figure 4-5-1):

- a) 15° above and below the horizontal, or
- b) 45° inboard or 80° outboard.

19. A modification to the vehicle has reduced the visibility angles of a mandatory lamp to less than (Figure 4-5-1):

- a) 15° above and below the horizontal, or
- b) 45° inboard or 80° outboard.

20. On a vehicle of American origin fitted with combined stop and indicator lamps, the stop lamp function is not overridden by the indicator function.

21. Where a lamp comprises an array of light sources (eg LEDs), fewer than 75% of these operate.

22. A visual lamp indicator device does not operate.

Note 1 Definitions

Modify means to change a vehicle from its original state by altering, substituting, adding or removing a structure, system, component or equipment, but does not include repair.

Repair means to restore a damaged or worn vehicle, its structure, systems, components or equipment to within safe tolerance of its condition when manufactured, including replacement with undamaged or new structures, systems, components or equipment.

Direction indicator lamp means a lamp designed to emit a flashing light to signal the intention of the driver to change the direction of the vehicle to the right or to the left.

Note 2 A permitted (ie non-mandatory) rear or a non-OE side-facing direction indicator lamp that does not comply with equipment, condition and performance requirements must be made to comply or disabled so that it does not emit a light.

Note 3 An original equipment (OE) lamp is one that is fitted by the vehicle manufacturer in the original position, or is an equivalent replacement or aftermarket lamp suitable for the position provided by the vehicle manufacturer for that lamp. All other lamps are considered retrofitted (ie non-OE).

Note 4 Vehicles first registered in New Zealand before 27 February 2005 may have rear direction indicator lamps that also function as reversing lamps.

Note 5 A vehicle originally manufactured with a direction indicator lamp arrangement that differs from what is required or permitted in this section may retain the original direction indicator lamps provided they remain fitted in their original position and perform as intended by the vehicle manufacturer.

Note 6 A forward-facing permitted lamp that does not comply with the equipment, condition and performance requirements must be made to comply or be removed from the vehicle.

Note 7 Some vehicles are equipped with OE or after-market daytime running lamps (DRLs) that also incorporate position lamp and direction indicator lamp functions. When the DRLs are on (when headlamps are off), and an indicator lamp is activated, the corresponding DRL is temporarily extinguished or dimmed. When the position lamps are on and an indicator lamp is activated, the corresponding position lamp may remain lit.

Lighting 4-5 Direction indicator lamps (cont.)

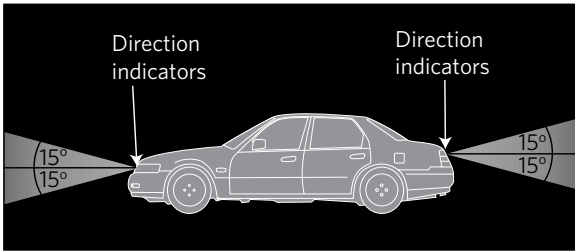

(a) Vertical beam angles

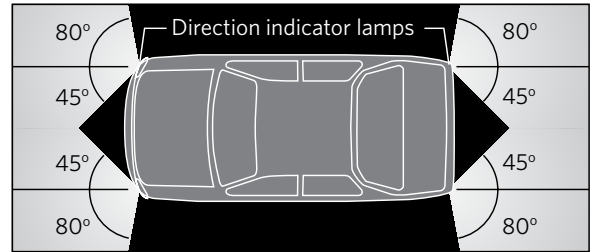

(b) Horizontal beam angles

Figure 4-5-1. Direction indicator beam angles

Lighting**4-5 Direction indicator lamps****Summary of legislation****Applicable legislation**

- Land Transport Rule: Vehicle Lighting 2004

Mandatory and permitted equipment

1. Refer to general vehicle pages.
2. A heavy vehicle of class MD3, MD4, ME, NB, or NC first registered on or after 1 January 1978 that exceeds 9.2 m in length must be fitted with one or two side-facing direction indicator lamps on each side, at or near the front of the vehicle.
3. A retrofitted side-facing direction indicator lamp must be mounted at a height not exceeding 1.5 m, or if this is not practicable due to the shape of the bodywork of the vehicle, not exceeding 2.1 m.
4. A heavy vehicle may be fitted with an additional pair of direction indicator lamps at the rear of the vehicle that must be symmetrically mounted as near the top corners of the bodywork of the vehicle as is practicable (top-mounted lamps).
5. Forward-facing or rearward-facing direction indicator lamps (excluding top-mounted lamps) may be mounted as follows:
 - a) one pair at a height from the ground not exceeding 1.5 m, or if this is not practicable due to the shape of the bodywork of the vehicle, not exceeding 2.1 m, and
 - b) a second pair at a height from the ground not exceeding 2.1 m.

Condition

6. Refer to general vehicle pages.

Performance

7. Refer to general vehicle pages.
8. A mandatory side-facing direction indicator must be visible from the side of the vehicle:
 - a) through an angle of 60° above and below the horizontal plane passing through the lamp, and
 - b) at least between an angle of 30° and 80° rearward of a vertical plane that is at right angles to the longitudinal centreline of the vehicle and passing through the lamp.

Modifications

9. Refer to general vehicle pages.

Reasons for rejection**Mandatory and permitted equipment**

1. Refer to general vehicle pages.
2. A heavy vehicle of class MD3, MD4, ME, NB, or NC first registered on or after 1 January 1978 that exceeds 9.2 m in length:
 - a) is not fitted with one side-facing direction indicator lamp on each side, at or near the front of the vehicle, or
 - b) is fitted with more than two side-facing direction indicator lamps on either side.
3. A retrofitted side-facing direction indicator lamp is fitted at a height from the ground exceeding 1.5 m (or 2.1 m where fitting below 1.5 m is not practicable due to the shape of the bodywork of the vehicle).
4. A heavy vehicle is fitted at the rear with:
 - a) only one top-mounted lamp, or
 - b) more than one pair of top-mounted lamps, or
 - c) top-mounted lamps that are not mounted symmetrically as close as is practicable to the top corners of the bodywork.
5. A pair of forward-facing or rearward-facing direction indicator lamps (other than top-mounted lamps):
 - a) in the case of a vehicle with one pair, is fitted at a height from the ground exceeding 1.5 m (or 2.1 m where fitting below 1.5 m is not practical due to the shape of the bodywork of the vehicle), or
 - b) in the case of a vehicle with two pairs:
 - i. the lower pair is fitted at a height from the ground exceeding 1.5 m (or 2.1 m where fitting below 1.5 m is not practical due to the shape of the bodywork of the vehicle), or
 - ii. the other pair is fitted at a height from the ground exceeding 2.1 m.
6. A heavy vehicle is fitted with top-mounted lamps at the front of the vehicle.

Condition

7. Refer to general vehicle pages.

Performance

8. Refer to general vehicle pages.

Lighting

4-5 Direction indicator lamps (cont.)

Reasons for rejection

9. A mandatory side-facing direction indicator lamp is not visible from the side of the vehicle (**Figure 4-5-2**):
- through an angle of 60° above and below a horizontal plane passing through the lamp, or
 - at least between an angle of 30° and 80° rearward of a vertical plane that is at right angles to the longitudinal centreline of the vehicle and passing through the lamp.

Note 1 Definitions

Modify means to change a vehicle from its original state by altering, substituting, adding or removing a structure, system, component or equipment, but does not include repair.

Repair means to restore a damaged or worn vehicle, its structure, systems, components or equipment to within safe tolerance of its condition when manufactured, including replacement with undamaged or new structures, systems, components or equipment.

Direction indicator lamp means a lamp designed to emit a flashing light to signal the intention of the driver to change the direction of the vehicle to the right or to the left.

Note 2 A permitted (ie non-mandatory) rear or a non-OE side-facing direction indicator lamp that does not comply with equipment, condition and performance requirements must be made to comply or disabled so that it does not emit a light.

Note 3 An original equipment (OE) lamp is one that is fitted by the vehicle manufacturer in the original position, or is an equivalent replacement or aftermarket lamp suitable for the position provided by the vehicle manufacturer for that lamp. All other lamps, **including those fitted by the body builder**, are considered retrofitted (ie non-OE).

Note 4 Vehicles first registered in New Zealand before 27 February 2005 may have rear direction indicator lamps that also function as reversing lamps.

Note 5 A vehicle originally manufactured with a direction indicator lamp arrangement that differs from what is required or permitted in this section may retain the original direction indicator lamps provided they remain fitted in their original position and perform as intended by the vehicle manufacturer. **This does not include lamps fitted by a body builder.**

Note 6 A forward-facing permitted direction indicator lamp that does not comply with the equipment, condition and performance requirements must be made to comply or be removed from the vehicle.

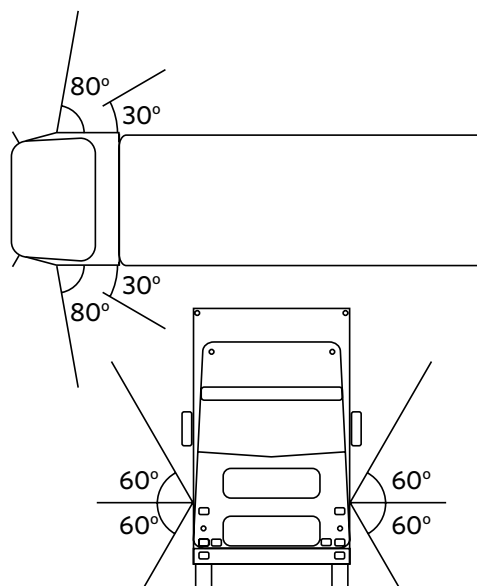

Figure 4-5-2. Required angles for side-facing direction indicator lamps

Lighting

4-6 Forward-facing position lamps

Summary of legislation

Applicable legislation

- Land Transport Rule: Vehicle Lighting 2004

Mandatory and permitted equipment

1. One pair of lamps must be fitted to:
 - a) a vehicle first registered in New Zealand on or after 1 January 1978 that exceeds 1.5 m in width
 - b) a vehicle that exceeds 2 m in width.
2. One or two lamps may be fitted to:
 - a) a vehicle that does not exceed 1.5 m in width
 - b) a vehicle first registered in New Zealand before 1 January 1978 that does not exceed 2 m in width.
3. A vehicle (eg a vintage or veteran vehicle) manufactured without lamps, or with lamps that cannot meet specified requirements, may obtain a WoF if:
 - a) the vehicle has a valid vehicle identity card with a lighting equipment endorsement, and
 - b) the vehicle meets the conditions of that endorsement.
4. A retrofitted pair of lamps must be symmetrically mounted as far towards each side of the vehicle as is practicable.
5. A retrofitted lamp must be mounted at a height from the ground not exceeding 1.5 m, or if this is not practicable due to the shape of the bodywork of the vehicle, not exceeding 2.1 m.

Condition

6. A forward-facing position lamp must:
 - a) be in sound condition
 - b) not be obscured (if a mandatory lamp).

Performance

7. A forward-facing position lamp must operate in a way that is appropriate for the lamp and the vehicle.
8. A lamp must emit a light that is:
 - a) diffuse, and
 - b) substantially white or amber, and
 - c) steady, and
 - d) sufficient to indicate to other road users the presence and dimensions of the vehicle, and
 - e) visible from 200 m in normal darkness, and
 - f) of approximately equal intensity and colour to the other lamp of a pair.

Reasons for rejection

Mandatory and permitted equipment

1. One pair of lamps is not fitted to:
 - a) a vehicle first registered in New Zealand on or after 1 January 1978 that exceeds 1.5 m in width, or
 - b) a vehicle that exceeds 2 m in width.
2. A vehicle is fitted with more than:
 - a) one pair of lamps, or
 - b) two single lamps.
3. A vehicle (eg a vintage or veteran vehicle) does not meet standard forward-facing position lamp requirements, and:
 - a) does not have a valid vehicle identity card with a lighting equipment endorsement, or
 - b) does not meet the conditions of the lighting equipment endorsement in its vehicle identity card.
4. A retrofitted lamp is mounted at a height from the ground exceeding 1.5 m (or 2.1 m where fitting below 1.5 m is not practicable due to the shape of the bodywork of the vehicle).
5. A retrofitted pair of lamps is:
 - a) not symmetrically mounted, or
 - b) not mounted as far towards each side of the vehicle as is practicable.

Condition

6. A lamp is insecure or contains visible moisture or dirt.
7. A lens is missing, or has a hole, crack or other damage that allows moisture or dirt to enter.
8. A lamp's reflector is damaged or has deteriorated so that light output is reduced.

Performance

9. When switched on, a forward-facing position lamp does not operate (**Note 5**).
10. When switched on, a forward-facing position lamp emits a light that is:

Lighting

4-6 Forward-facing position lamps (cont.)

9. A retrofitted mandatory lamp must be visible within angles of:
- 15° above and below the horizontal, and
 - 45° inboard, and
 - 80° outboard.
10. Where a lamp comprises an array of light sources (eg LEDs), at least 75% of these must operate.

Modifications (Note 1)

11. A forward-facing position lamp that is affected by a modification must meet the equipment, condition and performance requirements.

Reasons for rejection

- not substantially white or amber, or
 - not diffuse, or
 - not projected to the front, or
 - different in colour or intensity from the other lamp in a pair, or
 - not steady, or
 - not bright enough to be visible from 200 m in normal darkness, eg due to modification, deterioration or an incorrect light source, or
 - is altered, eg due to damage or modification.
11. A non-OE mandatory lamp mounted outside the original position emits a light that is not visible within (**Figure 4-6-1**):
- 15° above and below the horizontal, or
 - 45° inboard or 80° outboard.
12. A modification to the vehicle has reduced the visibility angles of a mandatory lamp to less than (**Figure 4-6-1**):
- 15° above and below the horizontal, or
 - 45° inboard or 80° outboard.
13. Where a lamp comprises an array of light sources (eg LEDs), fewer than 75% of these operate.

Note 1 Definitions

Modify means to change a vehicle from its original state by altering, substituting, adding or removing a structure, system, component or equipment, but does not include repair.

Repair means to restore a damaged or worn vehicle, its structure, systems, components or equipment to within safe tolerance of its condition when manufactured, including replacement with undamaged or new structures, systems, components or equipment.

Position lamp means a low-intensity lamp that is designed to indicate to road users the presence and dimensions of a vehicle, being:

- a forward-facing position lamp (front side lamp), or
- a rearward-facing position lamp (rear side lamp or tail lamp), or
- a side-marker lamp, or
- an end-outline marker lamp (including cab roof lamp).

Note 2 An original equipment (OE) lamp is one that is fitted by the vehicle manufacturer in the original position, or is an equivalent replacement or aftermarket lamp suitable for the position provided by the vehicle manufacturer for that lamp. All other lamps are considered retrofitted (ie non-OE).

Note 3 A vehicle originally manufactured with a forward-facing position lamp arrangement that differs from what is required or permitted in this section may retain the original forward-facing position lamps provided they remain fitted in their original position and perform as intended by the vehicle manufacturer.

Note 4 A forward-facing permitted lamp that does not comply with the equipment, condition and performance requirements must be made to comply or be removed from the vehicle.

Note 5 Some vehicles are equipped with OE or after-market daytime running lamps (DRLs) that also incorporate position lamp and direction indicator lamp functions. When the DRLs are on (when headlamps are off), and an indicator lamp is activated, the corresponding DRL is temporarily extinguished or dimmed. When the position lamps are on and an indicator lamp is activated, the corresponding position lamp may remain lit.

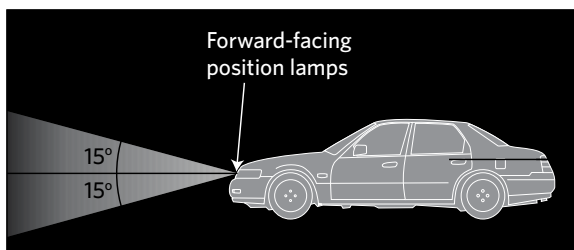

(a) Vertical beam angles

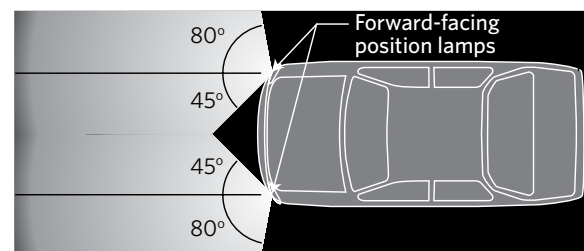

(b) Horizontal beam angles

Figure 4-6-1. Forward-facing position lamp beam angles

Lighting 4-6 Forward-facing position lamps

Summary of legislation

Applicable legislation

- Land Transport Rule: Vehicle Lighting 2004

Permitted equipment

- A heavy vehicle may be fitted with an additional pair of forward-facing position lamps that must be symmetrically mounted as near the top corners of the bodywork of the vehicle as is practicable (top-mounted lamps).

Condition

- Refer to general vehicle pages.

Performance

- Refer to general vehicle pages.

Modifications

- Refer to general vehicle pages.

Reasons for rejection

Mandatory and permitted equipment

- Refer to general vehicle pages.
- A heavy vehicle is fitted at the front with:
 - only one top-mounted lamp, or
 - more than one pair of top-mounted lamps, or
 - top-mounted lamps that are not mounted as close as is practicable to the top corners of the bodywork.

Condition

- Refer to general vehicle pages.

Performance

- Refer to general vehicle pages.

Note 1 The following total numbers of position lamps may generally be fitted to the front or rear of a vehicle:

Front of vehicle:

- one pair of forward-facing position lamps below 1.5 m (usually the OE lamps)
- one pair of forward-facing position lamps at the top corners
- two cab roof lamps
- 10 end-outline marker lamps fitted elsewhere on the outline of the vehicle or on the cab roof (for vehicles first registered in New Zealand before 27 February 2005 there is no restriction on the number of forward-facing end-outline marker lamps that may be fitted).

Rear of vehicle:

- two pairs of rearward-facing position lamps, one pair below 1.5 m and a second pair below 2.1 m, fitted symmetrically as far as possible towards the extremities
- one pair of rearward-facing position lamps at the top corners
- six end-outline marker lamps elsewhere on the outline of the vehicle.

Note 2 Definitions

Modify means to change a vehicle from its original state by altering, substituting, adding or removing a structure, system, component or equipment, but does not include repair.

Repair means to restore a damaged or worn vehicle, its structure, systems, components or equipment to within safe tolerance of its condition when manufactured, including replacement with undamaged or new structures, systems, components or equipment.

Position lamp means a low-intensity lamp that is designed to indicate to road users the presence and dimensions of a vehicle, being:

- a forward-facing position lamp (front side lamp), or
- a rearward-facing position lamp (rear side lamp or tail lamp), or
- a side-marker lamp, or
- an end-outline marker lamp (including cab roof lamp).

Lighting

4-6 Forward-facing position lamps (cont.)

Note 3 A permitted forward-facing position lamp, fitted to a class NC vehicle first registered in New Zealand before 27 February 2005, that does not comply with condition and performance requirements must be made to comply or be disabled so that it does not emit a light. All other permitted forward-facing position lamps that do not comply with requirements must be made to comply or be removed from the vehicle.

Note 4 An original equipment (OE) lamp is one that is fitted by the vehicle manufacturer in the original position, or is an equivalent replacement or aftermarket lamp suitable for the position provided by the vehicle manufacturer for that lamp. All other lamps, **including those fitted by the body builder**, are considered retrofitted (ie non-OE).

Note 5 A vehicle originally manufactured with a position lamp arrangement that differs from what is required or permitted in this section may retain the original position lamps provided they remain fitted in their original position and perform as intended by the vehicle manufacturer. **This does not include lamps fitted by a body builder.**

Lighting 4-7 Rearward-facing position lamps

Summary of legislation

Applicable legislation

- Land Transport Rule: Vehicle Lighting 2004

Mandatory and permitted equipment

- A vehicle first registered in New Zealand on or after 1 January 1978 and that is more than 1.5 m wide must be fitted with one or two pairs of rearward-facing position lamps.
- A vehicle of group M or N that was first registered in New Zealand before 1 January 1978 or that does not exceed 1.5 m in width must be fitted with:
 - one single rearward-facing position lamp in the centre or to the right of the centre of the vehicle, or
 - one or two pairs of rearward-facing position lamps.
- A vehicle of class LE that was first registered in New Zealand before 1 January 1978 or that does not exceed 1.5 m in width must be fitted with at least one rearward-facing position lamp.
- An emergency vehicle may be fitted with an additional pair of lamps that must be symmetrically mounted as near the top corners of the bodywork of the vehicle as is practicable (top-mounted lamps).
- A vehicle (eg a vintage or veteran vehicle) manufactured without lamps, or with lamps that cannot meet specified requirements, may obtain a WoF if:
 - the vehicle has a valid vehicle identity card with a lighting equipment endorsement, and
 - the vehicle meets the conditions of that endorsement.
- A retrofitted pair of lamps, other than top-mounted lamps, must be mounted:
 - symmetrically as far towards each side of the vehicle as is practicable, and
 - at a height from the ground not exceeding 1.5 m, or if this is not practicable due to the shape of the bodywork of the vehicle, not exceeding 2.1 m.

Condition

- A rearward-facing position lamp must:
 - be in sound condition, and
 - not be obscured (if a mandatory lamp).

Performance

- A rearward-facing position lamp must operate in a way that is appropriate for the lamp and the vehicle.
- A lamp must emit a light that is:
 - diffuse, and
 - substantially red.
- A lamp must emit a steady light.

Reasons for rejection

Mandatory and permitted equipment

- A vehicle first registered in New Zealand on or after 1 January 1978 that is more than 1.5 m wide:
 - is not fitted with one pair of lamps, or
 - is fitted with more than two pairs of lamps, or
 - is fitted with a lamp that is not in a pair, or
 - is an emergency vehicle and is fitted with more than three pairs of lamps, including top-mounted lamps.
- A group M or N vehicle first registered in New Zealand before 1 January 1978 or is less than 1.5 m wide is:
 - not fitted with one single lamp or one pair of lamps, or
 - fitted with more than one single lamp, or
 - fitted with more than two pairs of lamps.
- An emergency vehicle is fitted with:
 - more than one pair of top-mounted lamps, or
 - top-mounted lamps that are not mounted as close as is practicable to the top corners of the bodywork.
- A class LE vehicle that was first registered in New Zealand before 1 January 1978 or that is less than 1.5 m wide is not fitted with at least one lamp.
- A vehicle (eg a vintage or veteran vehicle) does not meet standard rearward-facing position lamp requirements, and:
 - does not have a valid vehicle identity card with a lighting equipment endorsement, or
 - does not meet the conditions of the lighting equipment endorsement in its vehicle identity card.
- A retrofitted lamp, other than a top-mounted lamp on an emergency vehicle, is mounted at a height from the ground exceeding 1.5 m (or 2.1 m where fitting below 1.5 m is not practicable due to the shape of the bodywork of the vehicle).
- A retrofitted pair of lamps:
 - is not symmetrically mounted, or

Lighting

4-7 Rearward-facing position lamps (cont.)

11. A lamp must provide sufficient light output to indicate to other road users the presence and dimensions of the vehicle.
12. A lamp must emit light that is visible from a distance of 200 m in normal darkness.
13. A retrofitted mandatory lamp must be visible within angles of 15° above and below the horizontal, and within 45° inboard and 80° outboard.
14. Each lamp in a pair must, when operated, emit a light of approximately equal intensity and colour.
15. Where a lamp comprises an array of light sources (eg LEDs), at least 75% of these must operate.

Modifications (Note 4)

16. A rearward-facing position lamp that is affected by a modification must meet equipment, condition and performance requirements.

Reasons for rejection

- b) is not mounted as far towards each side of the vehicle as is practicable.

Condition

8. A lamp is insecure or contains visible moisture or dirt.
9. A lens is missing, or has a hole, crack or other damage that allows moisture or dirt to enter.
10. A lamp's reflector is damaged or has deteriorated so that light output is reduced.

Performance

11. When switched on, a mandatory lamp does not operate.
12. When switched on, a lamp emits a light that is:
 - a) not substantially red, or
 - b) not diffuse, or
 - c) not projected to the rear, or
 - d) different in colour or intensity from that of the other lamp in a pair, or
 - e) not steady, or
 - f) not bright enough to be visible from 200 m in normal darkness, eg due to modification, deterioration or an incorrect light source, or
 - g) is altered, eg due to damage or modification.
13. A non-OE mandatory lamp mounted outside the original position emits a light that is not visible within:
 - a) 15° above and below the horizontal, or
 - b) 45° inboard or 80° outboard.
14. A modification to the vehicle has reduced the visibility angles of a mandatory lamp to less than:
 - a) 15° above and below the horizontal, or
 - b) 45° inboard or 80° outboard.
15. Where a lamp comprises an array of light sources (eg LEDs), fewer than 75% of these operate.

Note 1 Definitions

Modify means to change a vehicle from its original state by altering, substituting, adding or removing a structure, system, component or equipment, but does not include repair.

Repair means to restore a damaged or worn vehicle, its structure, systems, components or equipment to within safe tolerance of its condition when manufactured, including replacement with undamaged or new structures, systems, components or equipment.

Position lamp means a low-intensity lamp that is designed to indicate to road users the presence and dimensions of a vehicle, being:

- a) a forward-facing position lamp (front side lamp), or
- b) a rearward-facing position lamp (rear side lamp or tail lamp), or
- c) a side-marker lamp, or
- d) an end-outline marker lamp (including cab roof lamp).

Note 2 A permitted rearward-facing position lamp that does not comply with equipment, condition and performance requirements must be made to comply or be disabled so that it does not emit a light.

Note 3 An original equipment (OE) lamp is one that is fitted by the vehicle manufacturer in the original position, or is an equivalent replacement or aftermarket lamp suitable for the position provided by the vehicle manufacturer for that lamp. All other lamps are considered retrofitted (ie non-OE).

Note 4 A vehicle originally manufactured with a rearward-facing position lamp arrangement that differs from what is required or permitted in this section may retain the original rearward-facing position lamps provided they remain fitted in their original position and perform as intended by the vehicle manufacturer.

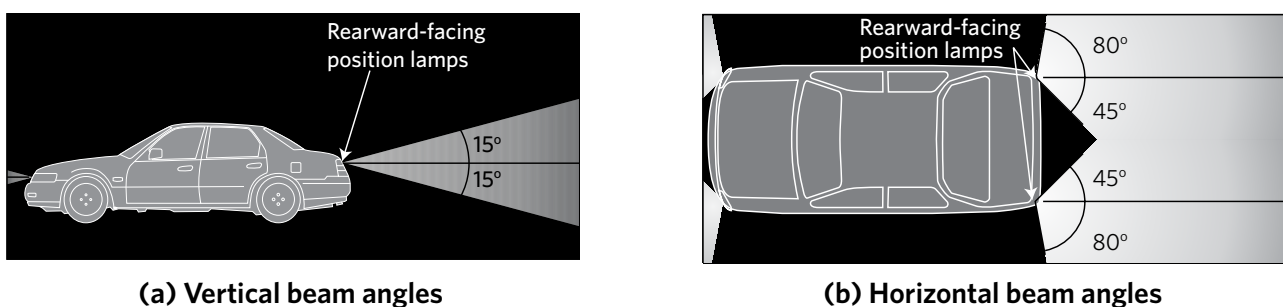

Figure 4-7-1. Rearward-facing position lamp beam angles

Lighting 4-7 Rearward-facing position lamps

Summary of legislation

Applicable legislation

- Land Transport Rule: Vehicle Lighting 2004

Permitted equipment

1. A heavy vehicle may be fitted with an additional pair of rearward-facing position lamps that must be symmetrically mounted as near the top corners of the bodywork of the vehicle as is practicable (top-mounted lamps).
2. Rearward-facing position lamps (excluding top-mounted lamps) may be mounted as follows:
 - a) one lamp or one pair at a height from the ground not exceeding 1.5 m, or if this is not practicable due to the shape of the bodywork of the vehicle, not exceeding 2.1 m, and
 - b) a second pair at a height from the ground not exceeding 2.1 m.

Condition

3. Refer to general vehicle pages.

Performance

4. Refer to general vehicle pages

Modifications

5. Refer to general vehicle pages.

Reasons for rejection

Mandatory and permitted equipment

1. Refer to general vehicle pages.
2. A heavy vehicle is fitted at the rear with:
 - a) only one top-mounted lamp, or
 - b) more than one pair of top-mounted lamps, or
 - c) top-mounted lamps that are not mounted as close as is practicable to the top corners of the bodywork.
3. A rearward-facing position lamp (other than top-mounted lamps):
 - a) in the case of a vehicle with one or one pair, is fitted at a height from the ground exceeding 1.5 m (or 2.1 m where fitting below 1.5 m is not practicable due to the shape of the bodywork of the vehicle), or
 - b) in the case of a vehicle with two pairs:
 - i. the lower pair is fitted at a height from the ground exceeding 1.5 m (or 2.1 m where fitting below 1.5 m is not practicable due to the shape of the bodywork of the vehicle), or
 - ii. the other pair is fitted at a height from the ground exceeding 2.1 m.

Condition

4. Refer to general vehicle pages.

Performance

5. Refer to general vehicle pages.

Note 1 Definitions

Modify means to change a vehicle from its original state by altering, substituting, adding or removing a structure, system, component or equipment, but does not include repair.

Repair means to restore a damaged or worn vehicle, its structure, systems, components or equipment to within safe tolerance of its condition when manufactured, including replacement with undamaged or new structures, systems, components or equipment.

Position lamp means a low-intensity lamp that is designed to indicate to road users the presence and dimensions of a vehicle, being:

- a) a forward-facing position lamp (front side lamp), or
- b) a rearward-facing position lamp (rear side lamp or tail lamp), or
- c) a side-marker lamp, or
- d) an end-outline marker lamp (including cab roof lamp).

Lighting

4-7 Rearward-facing position lamps (cont.)

Note 2 A permitted rearward-facing position lamp that does not comply with equipment, condition and performance requirements must be made to comply or be disabled so that it does not emit a light.

Note 3 An original equipment (OE) lamp is one that is fitted by the vehicle manufacturer in the original position, or is an equivalent replacement or aftermarket lamp suitable for the position provided by the vehicle manufacturer for that lamp. All other lamps, **including those fitted by the body builder**, are considered retrofitted (ie non-OE).

Note 4 A vehicle originally manufactured with a position lamp arrangement that differs from what is required or permitted in this section may retain the original position lamps provided they remain fitted in their original position and perform as intended by the vehicle manufacturer. **This does not include lamps fitted by a body builder.**

Lighting 4-8 Side-marker lamps

Summary of legislation

Applicable legislation

- Land Transport Rule: Vehicle Lighting 2004

Permitted and prohibited equipment

1. A light vehicle 6 m or more in length may be fitted with one or more side-marker lamps.
2. A side-marker lamp must be positioned so that it gives an indication of the vehicle's dimensions.
3. A light vehicle less than 6 m in length must not be fitted with a side-marker lamp.

Condition

4. A side-marker lamp must be in sound condition.

Performance

5. A side-marker lamp must operate in a way that is appropriate for the lamp and the vehicle.
6. A lamp must emit a light that is:
 - a) diffuse, and
 - b) substantially white or amber to the front, and
 - c) substantially red or amber to the rear.
7. A lamp must emit a steady light.
8. A side-marker lamp must provide sufficient light output to indicate to other road users the presence and dimensions of the vehicle.
9. A side-marker lamp must emit a light that is visible:
 - a) from a distance of 100 m in daylight and 200 m during the hours of darkness, and
 - b) within an angle of 60° above and below a horizontal plane passing through the lamp, and within an angle of 60° forward and rearward of a vertical plane that is perpendicular to the longitudinal centreline of the vehicle and passing through the lamp.
10. Where a lamp comprises an array of light sources (eg LEDs), at least 75% of these must operate.

Modifications

11. A side-marker lamp that is affected by a modification must meet equipment, condition and performance requirements.

Reasons for rejection

Permitted and prohibited equipment

1. A side-marker lamp is not positioned so that it gives an indication of the vehicle's dimensions.
2. A vehicle less than 6 m in length is fitted with a side-marker lamp.

Condition

3. A lamp is insecure or contains visible moisture or dirt.
4. A lens is missing, or has a hole, crack or other damage that allows moisture or dirt to enter.
5. A reflector is damaged or has deteriorated so that light output is reduced.

Performance

6. When switched on, a side-marker lamp emits a light that:
 - a) is not substantially white or amber to the front, or
 - b) is not substantially red or amber to the rear, or
 - c) is not diffuse, or
 - d) is not approximately of the same colour and intensity on each side of the vehicle, or
 - e) does not remain steadily illuminated, or
 - f) is not bright enough to produce light that is visible from 100 m in normal daylight and from 200 m in normal darkness, eg due to modification, deterioration or an incorrect light source.
7. A side-marker lamp emits a light that is not visible within (**Figure 4-8-1**):
 - a) 60° above and below the horizontal, or
 - b) 60° degrees forward and rearward.
8. Where a lamp comprises an array of light sources (eg LEDs), fewer than 75% of these operate.

Modifications

9. A side-marker lamp that is affected by a modification must meet equipment, condition and performance requirements.

Lighting

4-8 Side-marker lamps (cont.)

Note 1 Definitions

Side-marker lamp means a position lamp designed to be fitted to the side of a vehicle or its load.

Position lamp means a low-intensity lamp that is designed to indicate to road users the presence and dimensions of a vehicle, being:

- a) a forward-facing position lamp (front side lamp), or
- b) a rearward-facing position lamp (rear side lamp or tail lamp), or
- c) a side-marker lamp, or
- d) an end-outline marker lamp (including cab roof lamp).

Note 2 A permitted side-marker lamp that does not comply with equipment, condition and performance requirements must be made to comply or be disabled so that it does not emit a light.

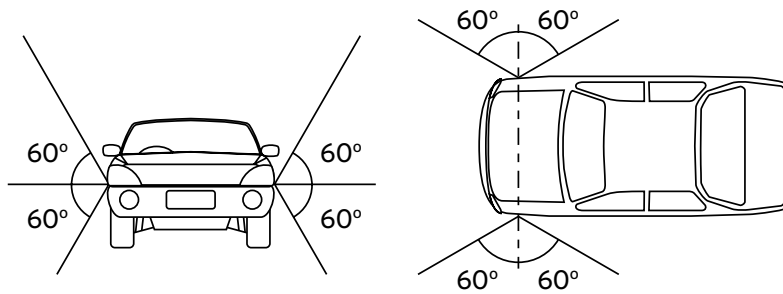

Figure 4-8-1. Visibility angles for side-marker lamps

Lighting 4-8 Side-marker lamps

Summary of legislation

Applicable legislation

- Land Transport Rule: Vehicle Lighting 2004

Permitted equipment

1. A heavy vehicle may be fitted with one or more side-marker lamps.
2. A side-marker lamp must be positioned so that it gives an indication of the vehicle's dimensions.

Condition

3. A side-marker lamp must:
 - a) be in sound condition, and
 - b) not be obscured (if a mandatory lamp).

Performance

4. A side-marker lamp must operate in a way that is appropriate for the lamp and the vehicle.
5. A lamp must emit a light that is:
 - a) diffuse, and
 - b) substantially white or amber to the front, and
 - c) substantially red or amber to the rear.
6. A lamp must emit a steady light.
7. A side-marker lamp must provide sufficient light output to indicate to other road users the presence and dimensions of the vehicle.
8. A side-marker lamp must emit a light that is visible:
 - a) from a distance of 100 m in daylight and 200 m during the hours of darkness, and
 - b) within an angle of 60° above and below a horizontal plane passing through the lamp, and within an angle of 60° forward and rearward of a vertical plane that is perpendicular to the longitudinal centreline of the vehicle and passing through the lamp.
9. Where a lamp comprises an array of light sources (eg LEDs), at least 75% of these must operate.

Modifications

10. A side-marker lamp that is affected by a modification must meet equipment, condition and performance requirements.

Reasons for rejection

Permitted equipment

1. A side-marker lamp is not positioned so that it gives an indication of the vehicle's dimensions.

Condition

2. A lamp is insecure or contains visible moisture or dirt.
3. A lens is missing, or has a hole, crack or other damage that allows moisture or dirt to enter.
4. A reflector is damaged or has deteriorated so that light output is reduced.

Performance

5. When switched on, a side-marker lamp emits a light that:
 - a) is not substantially white or amber to the front, or
 - b) is not substantially red or amber to the rear, or
 - c) is not diffuse, or
 - d) is not approximately of the same colour and intensity on each side of the vehicle, or
 - e) does not remain steadily illuminated, or
 - f) is not bright enough to produce light that is visible from 100 m in normal daylight and from 200 m in normal darkness, eg due to modification, deterioration or an incorrect light source.
6. A mandatory side-marker lamp emits a light that is not visible within (**Figure 4-8-1**):
 - a) 60° above and below the horizontal, or
 - b) 60° degrees forward and rearward.
7. Where a lamp comprises an array of light sources (eg LEDs), fewer than 75% of these operate.

Modifications

8. A side-marker lamp that is affected by a modification must meet equipment, condition and performance requirements.

Lighting

4-8 Side-marker lamps (cont.)

Note 1 Definitions

Side-marker lamp means a position lamp designed to be fitted to the side of a vehicle or its load.

Position lamp means a low-intensity lamp that is designed to indicate to road users the presence and dimensions of a vehicle, being:

- a) a forward-facing position lamp (front side lamp), or
- b) a rearward-facing position lamp (rear side lamp or tail lamp), or
- c) a side-marker lamp, or
- d) an end-outline marker lamp (including cab roof lamp).

Note 2 A permitted side-marker lamp that does not comply with equipment, condition and performance requirements must be made to comply or be disabled so that it does not emit a light.

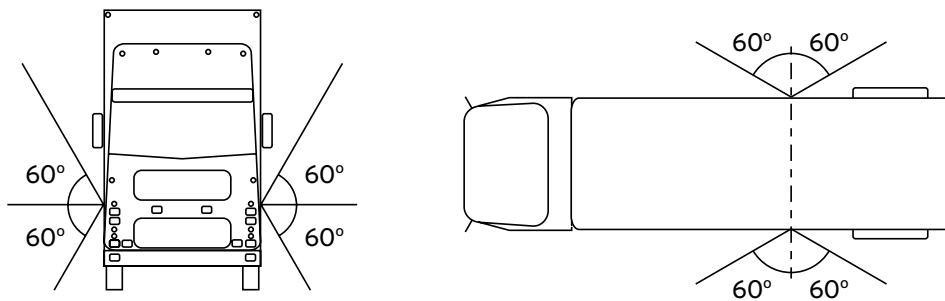

Figure 4-8-1. Visibility angles for side-marker lamps

Lighting

4-9 End-outline marker lamps

Summary of legislation

Applicable legislation

- Land Transport Rule: Vehicle Lighting 2004

Permitted and prohibited equipment

1. A light vehicle that has an overall width of more than 1.8 m may be fitted with a maximum of:
 - a) four forward-facing lamps, and
 - b) two rearward-facing lamps.
2. The position of the lamps must be such that it gives an indication of the vehicle's dimensions.
3. A light vehicle with an overall width of 1.8 m or less must not be fitted with end-outline marker lamps.

Condition

4. An end-outline marker lamp must be in sound condition.

Performance

5. An end-outline marker lamp must operate in a way that is appropriate for the lamp and the vehicle.
6. A lamp must emit a light that is:
 - a) diffuse, and
 - b) substantially white or amber to the front, and
 - c) substantially red to the rear.
7. A lamp must emit a steady light.
8. An end-outline marker lamp must provide sufficient light output to indicate to other road users the presence and dimensions of the vehicle.
9. Where a lamp comprises an array of light sources (eg LEDs), at least 75% of these must operate.

Modifications

10. An end-outline marker lamp that is affected by a modification must meet equipment, condition and performance requirements.

Reasons for rejection

Permitted and prohibited equipment

1. A light vehicle with an overall width of more than 1.8 m is fitted with:
 - a) more than four forward-facing lamps, or
 - b) more than two rearward-facing lamps.
2. A light vehicle with an overall width of less than 1.8 m is fitted with end-outline marker lamps.
3. The lamps are not positioned in such a way that they give an indication of the vehicles dimensions.

Condition

4. A lamp is insecure or contains visible moisture or dirt.
5. A lens is missing, or has a hole, crack or other damage that allows moisture or dirt to enter.
6. A reflector is damaged or has deteriorated so that light output is reduced.

Performance

7. When switched on, a forward-facing end-outline marker lamp does not operate (**Note 2**).
8. When switched on, an end-outline marker lamp emits a light that is:
 - a) not substantially white or amber to the front, or
 - b) not substantially red to the rear, or
 - c) not diffuse, or
 - d) not projected to the front or rear, or
 - e) not approximately of the same colour or intensity as the other lamp if fitted in a pair, or
 - f) not steady, or
 - g) not bright enough to indicate the presence and dimensions of the vehicle to other road users.
9. Where a lamp comprises an array of light sources (eg LEDs), fewer than 75% of these operate.

Note 1 Definitions

End-outline marker lamp means a position lamp designed to be fitted near the outer extremity of the vehicle in addition to forward-facing and rearward-facing position lamps, and includes a cab roof lamp.

Position lamp means a low-intensity lamp that is designed to indicate the presence and dimensions of a vehicle to other road users, being:

- a) a forward-facing position lamp (front side or park lamp), or
- b) a rearward-facing position lamp (rear side lamp or tail lamp), or
- c) a side-marker lamp, or
- d) an end-outline marker lamp (including cab roof lamp).

Note 2 A rearward-facing end-outline marker lamp that does not comply with the equipment, condition and performance requirements, must be made to comply or be disabled so that it does not emit a light. A non-complying forward-facing end-outline marker lamp must be made to comply or be fully removed from the vehicle.

Lighting 4-9 End-outline marker lamps

Summary of legislation

Applicable legislation

- Land Transport Rule: Vehicle Lighting 2004
- *New Zealand Gazette*, 12 May 1983, No. 63, page 1500
- *New Zealand Gazette*, 7 July 1977, No. 73, page 1893

Mandatory, permitted and prohibited equipment

1. A vehicle listed in **Table 4-9-1** must or may be fitted with end-outline marker lamps as specified in the table.
2. A vehicle not listed in **Table 4-9-1** must not be fitted with end-outline marker lamps.
3. An end-outline marker lamp must be positioned so that it gives an indication of the vehicle's dimensions.

Condition

4. An end-outline marker lamp must:
 - a) be in sound condition, and
 - b) not be obscured (if a mandatory lamp).

Performance

5. An end-outline marker lamp must operate in a way that is appropriate for the lamp and the vehicle.
6. A lamp must emit a light that is:
 - a) diffuse, and
 - b) substantially white or amber to the front, and
 - c) substantially red to the rear.
7. A lamp must emit a steady light.
8. An end-outline marker lamp must provide sufficient light output to indicate to other road users the presence and dimensions of the vehicle.
9. A mandatory cab roof lamp must emit a light that is visible from a distance of 100 m in daylight and 200 m during the hours of darkness.
10. Where a lamp comprises an array of light sources (eg LEDs), at least 75% of these must operate.

Modifications

11. An end-outline marker lamp that is affected by a modification must meet equipment, condition and performance requirements.

Reasons for rejection

Mandatory, permitted and prohibited equipment

1. A vehicle listed in **Table 4-9-1**:
 - a) is not fitted with the lamps required in **Table 4-9-1**, or
 - b) is fitted with lamps that exceed the numbers permitted in **Table 4-9-1**.
2. A vehicle not listed in **Table 4-9-1** is fitted with end-outline marker lamps.
3. An end-outline marker lamp is not positioned so that it gives an indication of the vehicle's dimensions, that is lamps, other than cab roof lamps, are fitted other than around the outline of the vehicle (**Note 2**).

Condition

4. A lamp is insecure, obscured (if a mandatory lamp), or contains visible moisture or dirt.
5. A lens is missing, or has a hole, crack or other damage that allows moisture or dirt to enter.
6. A reflector is damaged or has deteriorated so that light output is reduced.

Performance

7. When switched on, a mandatory or a forward-facing end-outline marker lamp does not operate (**Note 3**).
8. When switched on, an end-outline marker lamp emits a light that is:
 - a) not substantially white or amber to the front, or
 - b) not substantially red to the rear, or
 - c) not diffuse, or
 - d) not projected to the front or rear, or
 - e) not approximately of the same colour or intensity as the other lamp if fitted in a pair, or
 - f) not steady, or
 - g) not bright enough to indicate the presence and dimensions of the vehicle to other road users.
9. A mandatory cab roof lamp is not bright enough to produce light that is visible from 100 m in normal

Lighting

4-9 End-outline marker lamps (cont.)

Reasons for rejection

daylight and from 200 m in normal darkness, eg due to modification, deterioration or an incorrect light source.

10. Where a lamp comprises an array of light sources (eg LEDs), fewer than 75% of these operate.

Table 4-9-1. Fitting requirements for end-outline marker lamps

If the vehicle was:	Row	Characteristics of the heavy vehicle	Front		Rear
			Mandatory lamps ^{1,4}	Maximum permitted lamps ²	Maximum permitted lamps ²
Vehicle manufactured before 1/4/2011³	A	<ul style="list-style-type: none"> • A vehicle with a GVM exceeding 11,300 kg • A vehicle with a towing connection where the vehicle combination is likely to have a total length exceeding 9.2 m 	2	12 (No Limit if first registered before 27/2/2005)	6
	B	A vehicle with an overall width of 1.8 m or more (other than a vehicle in row A)	Not required	6	4
Vehicle manufactured from 1/4/2011	C	A vehicle with an overall width exceeding 2.1m <u>and</u> with a GVM or GCM exceeding 12,000kg	2	12	6
	D	A vehicle with an overall width exceeding 2.1m (other than a vehicle in row C)	2	6	4
	E	A vehicle with an overall width of 1.8 m or more (other than a vehicle in row C or D).	Not required	6	4

- ¹ Vehicles in Table 4-9-2 are not required to be fitted with mandatory lamps.
- ² Maximum permitted lamps are the maximum number of lamps allowed to be fitted, including mandatory lamps.
- ³ A vehicle manufactured before 1/4/2011 also has the option of complying with the requirements applicable to vehicles manufactured from 1/4/2011.
- ⁴ Mandatory lamps must be positioned at a height no lower than the top edge of the windscreen.

Table 4-9-2. Vehicles exempt from mandatory cab roof requirements

A vehicle fitted with a waste collection unit that incorporates front-loading container handling equipment and a cab protection shield, and which operates predominantly within 50 km/h speed limit zones during daylight hours only.
A PSV used exclusively on urban routes.
A vehicle designed principally for carrying ready-mix concrete no more than 9.2 m in length, and which operates predominantly in 50 km/h speed limit zones.



Note 1 For vehicles manufactured before 1/5/2011, the following total numbers of position lamps may generally be fitted to the front or rear of a vehicle:

Front of vehicle:

- a) one pair of forward-facing position lamps below 1.5 m (usually the OE lamps)
- b) one pair of forward-facing position lamps at the top corners
- c) two cab roof lamps
- d) 10 end-outline marker lamps fitted elsewhere on the outline of the vehicle or on the cab roof (for vehicles first registered in New Zealand before 27 February 2005 there is no restriction on the number of forward-facing end-outline marker lamps that may be fitted).

Rear of vehicle:

- a) two pairs of rearward-facing position lamps, one pair below 1.5 m and a second pair below 2.1 m, fitted symmetrically as far as possible towards the extremities
- b) one pair of rearward-facing position lamps at the top corners
- c) six end-outline marker lamps elsewhere on the outline of the vehicle.

Note 2 Definitions

End-outline marker lamp means a position lamp designed to be fitted near the outer extremity of the vehicle in addition to forward-facing and rearward-facing position lamps, and includes a cab roof lamp.

Position lamp means a low-intensity lamp that is designed to indicate the presence and dimensions of a vehicle to other road users, being:

- a) a forward-facing position lamp (front side or park lamp), or
- b) a rearward-facing position lamp (rear side lamp or tail lamp), or
- c) a side-marker lamp, or
- d) an end-outline marker lamp (including cab roof lamp).

Note 3 A rearward-facing end-outline marker lamp, or a forward-facing end-outline marker lamp fitted to a class NC vehicle first registered in New Zealand **before 27 February 2005**, that does not comply with the equipment, condition and performance requirements, must be made to comply or be disabled so that it does not emit a light. All other permitted forward-facing end-outline marker lamps must be made to comply or be fully removed from the vehicle.

Lighting 4-10 Stop lamps

Summary of legislation

Applicable legislation

- Land Transport Rule: Vehicle Lighting 2004

Mandatory and permitted equipment

1. A class LE vehicle:
 - a) first registered in New Zealand before 1 January 1978 may be fitted with one or two stop lamps.
 - b) first registered in New Zealand on or after 1 January 1978 must be fitted with one or two stop lamps
2. A group M or N vehicle:
 - a) first registered in New Zealand before 1 January 1978:
 - i. may be fitted with one, two or four stop lamps, or
 - ii. must be fitted with one, two or four stop lamps if its construction, equipment or loading prevents an arm signal given by the driver from being seen from behind the vehicle.
 - b) first registered in New Zealand on or after 1 January 1978 must be fitted with one or two pairs of stop lamps that emit a light that is visible from 100 m.
3. An emergency vehicle may be fitted with an additional pair of lamps that must be symmetrically mounted as near the top corners of the bodywork of the vehicle as is practicable (top-mounted lamps).
4. A vehicle (eg a vintage or veteran vehicle) manufactured without lamps, or with lamps that cannot meet specified requirements, may obtain a WoF if:
 - a) the vehicle has a valid vehicle identity card with a lighting equipment endorsement, and
 - b) the vehicle meets the conditions of that endorsement.
5. A retrofitted pair of stop lamps must be symmetrically mounted as far towards each side of the vehicle as is practicable.
6. A retrofitted stop lamp, other than a top-mounted lamp, must be fitted at a height from the ground not exceeding 1.5 m, or if this is not practicable due to the shape of the bodywork of the vehicle, not exceeding 2.1 m.
7. A vehicle (eg a vintage or veteran vehicle) manufactured without lamps, or with lamps that cannot meet specified requirements, may obtain a WoF if:
 - a) the vehicle has a valid vehicle identity card with a lighting equipment endorsement, and
 - b) the vehicle meets the conditions of that endorsement.

Condition

8. A stop lamp must:
 - a) be in sound condition, and
 - b) not be obscured (if a mandatory lamp).

Reasons for rejection

Mandatory and permitted equipment

1. A class LE vehicle first registered in New Zealand on or after 1 January 1978 is not fitted with one stop lamp.
2. A class LE vehicle is fitted with more than two stop lamps.
3. A group M or N vehicle first registered in New Zealand before 1 January 1978:
 - a) is not fitted with one stop lamp if the vehicle is so constructed that the driver's arm signals cannot be seen from behind the vehicle, or
 - b) is fitted with more than four stop lamps.
4. A group M or N vehicle first registered in New Zealand on or after 1 January 1978 is:
 - a) not fitted with one pair of stop lamps, or
 - b) fitted with more than two pairs of stop lamps, or
 - c) fitted with a stop lamp that is not in a pair.
 - d) an emergency vehicle and is fitted with more than three pairs of lamps, including top-mounted lamps.
5. An emergency vehicle is fitted with:
 - a) more than one pair of top-mounted lamps, or
 - b) top-mounted lamps that are not mounted as close as is practicable to the top corners of the bodywork.
6. A vehicle (eg vintage or veteran vehicle) does not meet standard stop lamp requirements, and:
 - a) does not have a valid vehicle identity card with a lighting equipment endorsement, or
 - b) does not meet the conditions of the lighting equipment endorsement in its vehicle identity card.
7. A retrofitted stop lamp, other than a top-mounted lamp on an emergency vehicle, is fitted at a height from the ground exceeding 1.5 m (or 2.1 m where fitting below 1.5 m is not practicable due to the shape of the bodywork of the vehicle).
8. A retrofitted pair of lamps is not:
 - a) symmetrically mounted, or
 - b) mounted as far towards each side of the vehicle as is practicable.

Lighting 4-10 Stop lamps (cont.)

Performance

9. A stop lamp must operate in a way that is appropriate for the lamp and the vehicle.
10. The light emitted from a stop lamp must be diffuse light that is substantially red.
11. A required stop lamp must operate when a service brake is activated.
12. A required stop lamp must provide sufficient light output to fulfil its intended purpose.
13. A stop lamp must emit a steady light.
14. A retrofitted mandatory stop lamp must emit a light that is visible within the angles of 15° above and below the horizontal, and 45° inboard and outboard.
15. If a vehicle of American origin is fitted with combined stop and direction indicator lamps, the indicator lamps must override the stop lamps so that the stop lamps will operate as direction indicators.
16. Where a stop lamp comprises an array of light sources (eg LEDs), at least 75% of these must operate.

Modifications (Note 1)

17. A stop lamp that is affected by a modification must meet equipment, condition and performance requirements.

Reasons for rejection

9. A vehicle (eg a vintage or veteran vehicle) does not meet standard stop lamp requirements, and:
 - a) does not have a valid vehicle identity card with a lighting equipment endorsement, or
 - b) does not meet the conditions of the lighting equipment endorsement in its vehicle identity card.

Condition

10. A lamp is insecure or contains visible moisture or dirt.
11. A lens is missing, or has a hole, crack or other damage that allows moisture or dirt to enter.
12. A reflector is damaged or has deteriorated so that light output is reduced.

Performance

13. When the service brake is activated:
 - a) a mandatory lamp does not operate, or
 - b) a lamp does not remain steadily illuminated.
14. A lamp operates when the service brake is not applied.
15. A lamp emits a light that is:
 - a) not substantially red, or
 - b) not diffuse, or
 - c) not projected to the rear, or
 - d) different in intensity from the other lamp in a pair, or
 - e) not bright enough to produce a light that is visible from 100 m in normal daylight, eg due to modification, deterioration or an incorrect light source, or
 - f) is altered, eg due to damage or modification.
16. A non-OE mandatory lamp mounted outside the original position emits a light that is not visible within:
 - a) 15° above and below the horizontal, or
 - b) 45° inboard and outboard.
17. A modification to the vehicle has reduced the visibility angles of a mandatory lamp to less than:
 - a) 15° above and below the horizontal, or
 - b) 45° inboard and outboard.

Reasons for rejection

18. Where a lamp comprises an array of light sources (eg LEDs), fewer than 75% of these operate.
19. On a vehicle of American origin fitted with combined stop and direction indicator lamps, the stop lamp function is not overridden by the indicator function.

Note 1 Definitions

Modify means to change a vehicle from its original state by altering, substituting, adding or removing a structure, system, component or equipment, but does not include repair.

Repair means to restore a damaged or worn vehicle, its structure, systems, components or equipment to within safe tolerance of its condition when manufactured, including replacement with undamaged or new structures, systems, components or equipment.

Stop lamp means a lamp that is designed to operate when the service brake is activated.

Note 2 A permitted stop lamp that does not comply with equipment, condition and performance requirements must be made to comply or be disabled so that it does not emit a light.

Note 3 An original equipment (OE) lamp is one that is fitted by the vehicle manufacturer in the original position, or is an equivalent replacement or aftermarket lamp suitable for the position provided by the vehicle manufacturer for that lamp. All other lamps are considered retrofitted (ie non-OE).

Note 4 A vehicle originally manufactured with a stop lamp arrangement that differs from what is required or permitted in this section may retain the original stop lamps provided they remain fitted in their original position and perform as intended by the vehicle manufacturer.

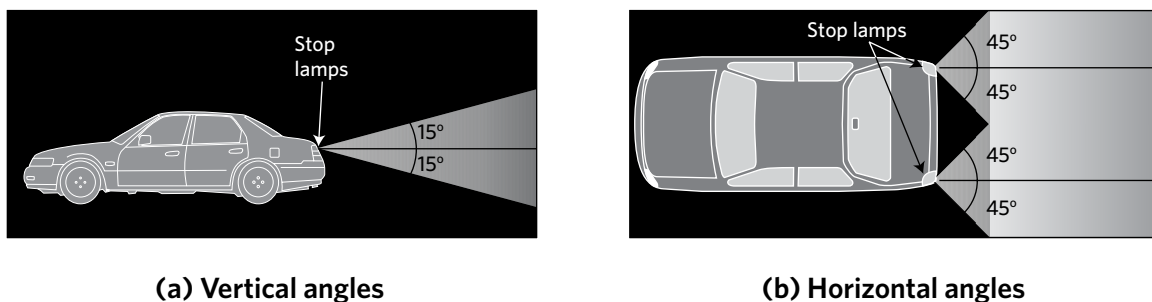

Figure 4-10-1. Stop lamp visibility angles

Lighting 4-10 Stop lamps

Summary of legislation

Applicable legislation

- Land Transport Rule: Vehicle Lighting 2004

Permitted equipment

- A heavy vehicle may be fitted with an additional pair of stop lamps that must be symmetrically mounted as near the top corners of the bodywork of the vehicle as is practicable (top-mounted lamps).
- Stop lamps (excluding top-mounted lamps) may be mounted as follows:
 - one lamp or one pair at a height from the ground not exceeding 1.5 m, or if this is not practicable due to the shape of the bodywork of the vehicle, not exceeding 2.1 m, and
 - a second pair at a height from the ground not exceeding 2.1 m.

Condition

- Refer to general vehicle pages.

Performance

- Refer to general vehicle pages.

Modifications

- Refer to general vehicle pages.

Reasons for rejection

Mandatory and permitted equipment

- Refer to general vehicle pages.
- A heavy vehicle is fitted at the rear with:
 - only one top-mounted lamp, or
 - more than one pair of top-mounted lamps, or
 - top-mounted lamps that are not mounted as close as is practicable to the top corners of the bodywork.
- A stop lamp (other than top-mounted lamps):
 - in the case of a vehicle with one or one pair, is fitted at a height from the ground exceeding 1.5 m (or 2.1 m where fitting below 1.5 m is not practicable due to the shape of the bodywork of the vehicle), or
 - in the case of a vehicle with two pairs:
 - the lower pair is fitted at a height from the ground exceeding 1.5 m (or 2.1 m where fitting below 1.5 m is not practicable due to the shape of the bodywork of the vehicle), or
 - the other pair is fitted at a height from the ground exceeding 2.1 m.

Condition

- Refer to general vehicle pages.

Performance

- Refer to general vehicle pages.

Note 1 Definitions

Modify means to change a vehicle from its original state by altering, substituting, adding or removing a structure, system, component or equipment, but does not include repair.

Repair means to restore a damaged or worn vehicle, its structure, systems, components or equipment to within safe tolerance of its condition when manufactured, including replacement with undamaged or new structures, systems, components or equipment. Stop lamp means a lamp that is designed to operate when the service brake is applied.

Note 2 A permitted stop lamp that does not comply with condition and performance requirements must be made to comply or be disabled so that it does not emit a light.

Note 3 An original equipment (OE) lamp is one that is fitted by the vehicle manufacturer in the original position, or is an equivalent replacement or aftermarket lamp suitable for the position provided by the vehicle manufacturer for that lamp. All other lamps, **including those fitted by a body builder**, are considered retrofitted (ie non-OE).

Note 4 A vehicle originally manufactured with a stop lamp arrangement that differs from what is required or permitted in this section may retain the original stop lamps provided they remain fitted in their original position and perform as intended by the vehicle manufacturer. **This does not include lamps fitted by a body builder.**

Lighting

4-11 High-mounted stop lamps

Summary of legislation

Applicable legislation

- Land Transport Rule: Vehicle Lighting 2004

Mandatory and permitted equipment

- A class MA vehicle first registered in New Zealand on or after 1 January 1990 must be fitted with one or two high-mounted stop lamps.
- Any other vehicle may be fitted with one or two high-mounted stop lamps.
- A lamp on a group M or N vehicle must be fitted in a central high-mounted position at the rear of the vehicle.
- No part of a lamp's illuminated surface must be lower than 150 mm below the bottom edge of the rear window, except where there is no rear window fitted or visible from behind the vehicle.
- A vehicle (eg a vintage or veteran vehicle) manufactured without lamps, or with lamps that cannot meet specified requirements, may obtain a WoF if:
 - the vehicle has a valid vehicle identity card with a lighting equipment endorsement, and
 - the vehicle meets the conditions of that endorsement.

Condition

- A high-mounted stop lamp must be in good condition.
- At least one high-mounted stop lamp must not be obscured.

Performance

- A high-mounted stop lamp must operate in a way that is appropriate for the lamp and the vehicle.
- The light emitted from a high-mounted stop lamp must be diffuse light that is substantially red.
- A high-mounted stop lamp must emit a steady light.
- At least one unobscured lamp must operate when the vehicle's service brakes are activated.
- Where a high-mounted stop lamp comprises an array of light sources (eg LEDs), at least 75% of these must operate.

Modifications

- A high-mounted stop lamp that is affected by a modification:
 - must meet equipment, condition and performance requirements, and
 - does not require LVV specialist certification.

Reasons for rejection

Mandatory and permitted equipment

- A class MA vehicle first registered in New Zealand on or after 1 January 1990 is not fitted with one high-mounted stop lamp.
- A vehicle is fitted with more than two high-mounted stop lamps.
- A lamp is not fitted in a central high-mounted position.
- A lamp fitted to a group M or N vehicle, except one that does not have a rear window, or that does not have a rear window visible from the rear, has an illuminated surface that is lower than 150 mm below the bottom edge of the rear window.
- A vehicle (eg a vintage or veteran vehicle) does not meet standard stop lamp requirements, and:
 - does not have a valid vehicle identity card with a lighting equipment endorsement, or
 - does not meet the conditions of the lighting equipment endorsement in its vehicle identity card.

Condition

- A lamp is insecure, or contains visible moisture or dirt.
- A mandatory lamp (**Note 2**) is obscured.
- A lens is missing, or has a hole, crack or other damage that allows moisture or dirt to enter.
- A reflector is damaged or has deteriorated so that light output is reduced.

Performance

- When the service brake is activated:
 - a mandatory (**Note 2**) lamp does not operate, or
 - a lamp does not remain steadily illuminated.
- A lamp operates when the service brake is not activated.
- A lamp emits a light that is not:
 - substantially red, or
 - diffuse, or
 - projected to the rear, or

Lighting

4-11 High-mounted stop lamps (cont.)

Reasons for rejection

- d) bright enough to be visible from 100 m in normal daylight, eg due to modification, deterioration or an incorrect light source
- 13. Where a lamp comprises an array of light sources (eg LEDs), fewer than 75% of these operate.

Note 1 Definitions

High-mounted stop lamp means a stop lamp that is designed to be fitted in a central, high-mounted position at the rear of a vehicle.

Stop lamp means a lamp that is designed to operate when the service brake is activated.

Note 2 Mandatory lamp - the vehicle must have one high-mounted stop lamp that meets the equipment, condition and performance requirements. Any other high-mounted stop lamp is a permitted lamp. The permitted lamp is not required to operate, but if it does operate, it must meet the equipment, condition and performance requirements, although it may be obscured.

Note 3 A vehicle originally manufactured with a high-mounted stop lamp arrangement that differs from what is required or permitted in this section may retain the original high-mounted stop lamps provided they remain fitted in their original position and perform as intended by the vehicle manufacturer.

Lighting

4-12 Rear-registration-plate illumination lamps

Summary of legislation

Applicable legislation

- Land Transport Rule: Vehicle Lighting 2004

Mandatory equipment

1. At least one rear-registration-plate illumination lamp.
2. A vehicle (eg a vintage or veteran vehicle) manufactured without lamps, or with lamps that cannot meet specified requirements, may obtain a WoF if:
 - a) the vehicle has a valid vehicle identity card with a lighting equipment endorsement, and
 - b) the vehicle meets the conditions of that endorsement.

Performance

3. A rear-registration-plate illumination lamp must operate in a way that is appropriate for the lamp and the vehicle.
4. A lamp must emit a diffuse light that is substantially white.
5. A rear-registration-plate illumination lamp must emit a steady light.
6. The light source of the lamp must not be visible from the rear of the vehicle.
7. A lamp must illuminate the figures and letters of the plate so that they are visible from 20 m during normal darkness.
8. Where a lamp comprises an array of light sources (eg LEDs), at least 75% of these must operate.

Modifications

9. A rear-registration-plate illumination lamp that is affected by a modification must meet equipment, condition and performance requirements.

Reasons for rejection

Mandatory equipment

1. A vehicle is not fitted with at least one rear-registration-plate illumination lamp.
2. A vehicle (eg a vintage or veteran vehicle) does not meet standard rear-registration-plate illumination lamp requirements, and:
 - a) does not have a valid vehicle identity card with a lighting equipment endorsement, or
 - b) does not meet the conditions of the lighting equipment endorsement in its vehicle identity card.

Performance

3. The lamp emits a light that is not:
 - a) substantially white, or
 - b) steady, or
 - c) diffuse.
4. The lamps are not bright enough to show up the registration plate text from 20 m in normal darkness.
5. The light source of a lamp is visible from the rear of the vehicle.

Note 1 Definitions

Rear-registration-plate illumination lamp means a lamp designed to illuminate the rear registration plate of a vehicle.

Modify means to change a vehicle from its original state by altering, substituting, adding or removing a structure, system, component or equipment, but does not include repair.

Repair means to restore a damaged or worn vehicle, its structure, systems, components or equipment to within safe tolerance of its condition when manufactured, including replacement with undamaged or new structures, systems, components or equipment.

Note 2 A vehicle originally manufactured with a rear-registration-plate illumination lamp arrangement that differs from what is required or permitted in this section may retain the original rear-registration-plate illumination lamps provided they remain fitted in their original position and perform as intended by the vehicle manufacturer.

Lighting 4-13 Rear reflectors

Summary of legislation

Applicable legislation

- Land Transport Rule: Vehicle Lighting 2004

Mandatory and permitted equipment

1. A group M or N vehicle must be fitted with at least one pair of rearward-facing reflectors at a height from the ground not exceeding 1.5 m, or if this is not practicable due to the shape of the bodywork of the vehicle, not exceeding 2.1 m.
2. A class LE vehicle must be fitted with at least one rearward-facing reflector that reflects light that is visible from 100 m.
3. A rearward-facing reflector must be positioned to the rear of the vehicle.
4. A reflector must be of an area that allows it to reflect light to improve the visibility of the vehicle to other road users, but it must not cause them undue dazzle or discomfort.
5. A retrofitted pair of reflectors must be symmetrically mounted as far towards each side of the vehicle as is practicable.

Condition

6. A reflector must be in good condition.

Performance

7. A reflector must operate in a way that is appropriate for the reflector and the vehicle.
8. A reflector must reflect white light as substantially red light.
9. A reflector must provide sufficient light reflection to fulfil its intended purpose.

Modifications

10. A rear reflector that is affected by a modification:
 - a) must meet equipment, condition and performance requirements, and
 - b) does not require LVV specialist certification.

Reasons for rejection

Mandatory and permitted equipment

1. A group M or N vehicle:
 - a) is not fitted with at least one red rearward-facing reflector on each side, or
 - b) is fitted with a red rearward-facing reflector that is not in a pair.
2. A class LE vehicle is not fitted with at least one red rearward-facing reflector.
3. A reflector is not positioned to the rear of the vehicle.
4. A retrofitted reflector is fitted at a height from the ground exceeding 1.5 m (or 2.1 m where fitting below 1.5 m is not practicable due to the shape of the bodywork of the vehicle).
5. A retrofitted pair of reflectors is not:
 - a) symmetrically mounted, or
 - b) mounted as far towards each side of the vehicle as is practicable.

Condition

6. A mandatory reflector's ability to reflect light is affected by excessive:
 - a) fading, or
 - b) scratching or other damage.

Performance

7. The reflected light from a mandatory reflector is not visible from 100 m.
8. The reflected light from a reflector is not red.

Note 1 Definitions

Reflector means a distinct item of lighting equipment that is designed to reflect incident light back towards the light source, but does not include reflective material (such as reflective tape).

Reflective material means any material that is designed to reflect incident light back towards the light source and includes reflective tape, but does not include a reflector.

Note 2 A vehicle originally manufactured with a rear reflector arrangement that differs from what is required or permitted in this section may retain the original rear reflectors provided they remain fitted in their original position and perform as intended by the vehicle manufacturer.

Lighting 4-13 Rear reflectors

Summary of legislation

Applicable legislation

- Land Transport Rule: Vehicle Lighting 2004

Mandatory equipment

1. Refer to general vehicle pages.
2. A rearward-facing reflector fitted to a class NB or NC vehicle must have an area of at least 30 cm² and be fitted within 150 mm on the right and left extremities of the vehicle.

Condition

3. Refer to general vehicle pages.

Performance

4. Refer to general vehicle pages.

Modifications

5. Refer to general vehicle pages.

Reasons for rejection

Mandatory equipment

1. Refer to general vehicle pages.
2. A rearward-facing reflector fitted to a class NB or NC vehicle:
 - a) does not have an area of at least 30 cm², or
 - b) is not fitted within 150 mm on the right and left extremities of the vehicle.

Condition

3. Refer to general vehicle pages.

Performance

4. Refer to general vehicle pages.

Modifications

5. Refer to general vehicle pages.

Lighting 4-14 Reversing lamps

Summary of legislation

Applicable legislation

- Land Transport Rule: Vehicle Lighting 2004

Permitted equipment

- One or two reversing lamps fitted at the rear of the vehicle.
- A retrofitted pair of reversing lamps must be symmetrically mounted as far towards each side of the vehicle as is practicable.

Condition

- A reversing lamp must be in good condition.

Performance

- A reversing lamp must operate in a way that is appropriate for the lamp and the vehicle.
- A reversing lamp, when operated, must emit a diffuse light or a dipped beam of light that is substantially white (**Note 3**).
- A reversing lamp must emit a steady light.
- A reversing lamp may operate only when the reverse gear is engaged or the headlamps are turned off.
- Where a reversing lamp comprises an array of light sources (eg LEDs), at least 75% of these must operate.

Modifications

- A reversing lamp that is affected by a modification:
 - must meet equipment, condition and performance requirements, and
 - does not require LVV specialist certification.

Reasons for rejection

Permitted equipment

- A vehicle is fitted with more than two reversing lamps at the rear of the vehicle.
- A retrofitted pair of reversing lamps is not:
 - symmetrically mounted, or
 - mounted as far towards each side of the vehicle as is practicable.

Condition

- A lamp is insecure, obscured or contains visible moisture or dirt.
- A lens is missing, or has a hole, crack or other damage that allows moisture or dirt to enter.
- A reflector is damaged or has deteriorated so that light output is reduced.

Performance

- A lamp controlled by gear engagement continues to display a light to the rear when the reverse gear is disengaged.
- A lamp controlled by a manual switch continues to display a light to the rear while the headlamps are switched on.
- When engaged, a lamp emits light that is not:
 - substantially white (**Note 3**), or
 - steady, or
 - diffuse or a dipped beam.
- Where a lamp comprises an array of light sources (eg LEDs), fewer than 75% of these operate.

Note 1 Definitions

Reversing lamp means a lamp designed to illuminate the area behind the vehicle while it is reversing and to warn other road users that the vehicle is reversing or about to reverse.

Note 2 A reversing lamp that does not comply with equipment, condition and performance requirements must be made to comply or be disabled so that it does not emit a light.

Note 3 Vehicles first registered in New Zealand before 27 February 2005 were allowed to use rear indicator lamps as reversing lamps. Although the light emitted is amber rather than white, this arrangement is still permitted for these vehicles.

Note 4 A vehicle originally manufactured with a reversing lamp arrangement that differs from what is required or permitted in this section may retain the original reversing lamps provided they remain fitted in their original position and perform as intended by the vehicle manufacturer.

Lighting 4-15 Cosmetic lamps

Summary of legislation

Applicable legislation

- Land Transport Rule: Vehicle Lighting 2004

Permitted equipment

1. A vehicle may be fitted with one or more lamps not specified in **Table 4-15-1**, provided they are fitted so that light sources are not visible in those regions specified in **Figure 4-15-1**.
2. A lamp must be fitted in a fixed position on the vehicle and positioned so that no part of the light source is situated within 250 mm of a mandatory lamp.

Performance

3. A lamp must:
 - a) only emit light that is diffuse, and
 - b) not emit light that flashes or otherwise varies in intensity or colour, and
 - c) be fitted in a way, and be of a luminance that ensures, that it does not dazzle, confuse or distract other road users, and
 - d) not emit a light that revolves, rotates or otherwise moves, and
 - e) not cause confusion as to the orientation of the vehicle, and
 - f) not emit a red light that is directly visible from the front of the vehicle, and
 - g) not emit a light other than red or amber if the light is directly visible from the rear of the vehicle.

Reasons for rejection

Permitted equipment

1. A cosmetic lamp (ie one not listed in **Table 4-15-1**) that is fitted to a vehicle:
 - a) has a part of its light-emitting surface positioned within 250 mm of any mandatory lamp, or
 - b) is not mounted in a fixed position, or
 - c) is positioned so that its light-emitting surface is visible within the shaded areas in **Figure 4-15-1**.

Performance

2. When switched on, a cosmetic lamp with a light-emitting surface not visible within the shaded areas in **Figure 4-15-1** emits a light that:
 - a) is not diffuse, or
 - b) flashes or otherwise varies in intensity or colour, or
 - c) revolves, rotates or otherwise moves, or
 - d) is too bright and likely to dazzle other road users, or
 - e) is likely to cause confusion about the orientation of the vehicle, or
 - f) is red when seen directly from the front, or
 - g) is not red or amber when seen directly from the rear.

Lighting 4-15 Cosmetic lamps (cont.)

Table 4-15-1. Lamps that are not cosmetic lamps

Lamps covered in the VIRM	Other lighting equipment not requiring inspection
Headlamps	Reflective material
Stop lamps	Interior lamps <i>Designed to illuminate the interior of the vehicle for the convenience of passengers</i>
High-mounted stop lamps	Work lamps
Direction indicator lamps	<i>White or amber high-intensity lamps that are not necessary for the operation of the vehicle but are designed to illuminate the area around the vehicle or the vehicle itself</i>
Position lamps (includes side-marker lamps and end-outline marker lamps)	Scene lamps <i>Work lamps designed to provide a fixed or movable beam of light to illuminate the area around the vehicle or the vehicle itself</i>
Rear-registration-plate illumination lamps	Alley lamps <i>Work lamps designed primarily to provide a fixed or movable beam of light to the side of the vehicle it is fitted to</i>
Rear reflectors	Flashing or revolving beacons
Fog lamps	Illuminated vehicle-mounted signs <i>Includes PSV destination signs, taxi signs and variable message signs operated by enforcement officers, under a traffic management plan or permitted by other legislation</i>
Daytime running lamps	
Cornering lamps	
Reversing lamps	
PSV interior lamps	

Note 1 A rear or side cosmetic lamp that does not comply with requirements for condition or performance must be made to comply, or be disabled so that it does not emit a light.

Note 2 Definitions

Lamp means a device designed to emit light, and includes an array of separate light sources that appear as a continuous illuminated surface.

Cosmetic lamp means any lamp that is not listed in **Table 4-15-1**.

Note 3 A forward-facing cosmetic lamp that does not comply with the equipment, condition and performance requirements must be made to comply or be removed from the vehicle.

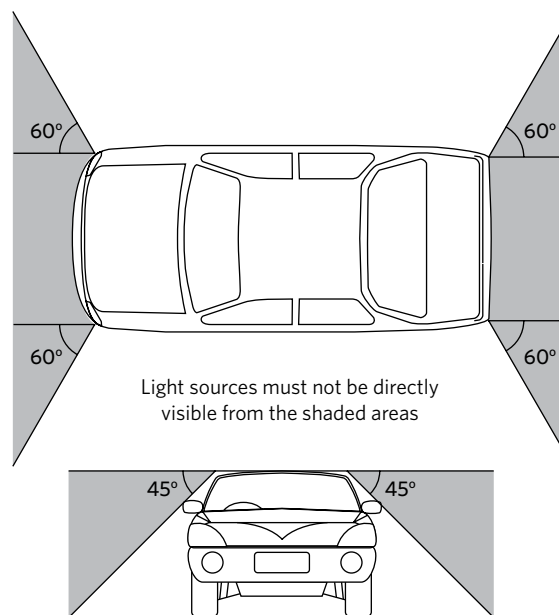

Figure 4-15-1. Visibility angles for cosmetic lamps

Lighting 4-15 Cosmetic lamps

Summary of legislation

Applicable legislation

- Land Transport Rule: Vehicle Lighting 2004

Permitted equipment

1. A vehicle may be fitted with one or more lamps not specified in **Table 4-15-1**, provided they are fitted so that light sources are not visible in those regions specified in **Figure 4-15-1**.
2. A lamp must be fitted in a fixed position on the vehicle and positioned so that no part of the light source is situated within 250 mm of a mandatory lamp.

Performance

3. A lamp must:
 - a) only emit light that is diffuse, and
 - b) not emit light that flashes or otherwise varies in intensity or colour, and
 - c) be fitted in a way, and be of a luminance that ensures, that it does not dazzle, confuse or distract other road users, and
 - d) not emit a light that revolves, rotates or otherwise moves, and
 - e) not cause confusion as to the orientation of the vehicle, and
 - f) not emit a red light that is directly visible from the front of the vehicle, and
 - g) not emit a light other than red or amber if the light is directly visible from the rear of the vehicle.

Reasons for rejection

Permitted equipment

1. A cosmetic lamp (ie one not listed in **Table 4-15-1**) that is fitted to a vehicle:
 - a) has a part of its light-emitting surface positioned within 250 mm of any mandatory lamp, or
 - b) is not mounted in a fixed position, or
 - c) is positioned so that its light-emitting surface is visible within the shaded areas in **Figure 4-15-1**.

Performance

2. When switched on, a cosmetic lamp with a light-emitting surface not visible within the shaded areas in **Figure 4-15-1** emits a light that:
 - a) is not diffuse, or
 - b) flashes or otherwise varies in intensity or colour, or
 - c) revolves, rotates or otherwise moves, or
 - d) is too bright and likely to dazzle other road users, or
 - e) is likely to cause confusion about the orientation of the vehicle, or
 - f) is red when seen directly from the front, or
 - g) is not red or amber when seen directly from the rear.

Lighting 4-15 Cosmetic lamps (cont.)

Table 4-15-1. Lamps that are not cosmetic lamps

Lamps covered in the VIRM	Other lighting equipment not requiring inspection
Headlamps	Reflective material
Stop lamps	Interior lamps <i>Designed to illuminate the interior of the vehicle for the convenience of passengers</i>
High-mounted stop lamps	Work lamps
Direction indicator lamps	<i>White or amber high-intensity lamps that are not necessary for the operation of the vehicle but are designed to illuminate the area around the vehicle or the vehicle itself</i>
Position lamps (includes side-marker lamps and end-outline marker lamps)	Scene lamps <i>Work lamps designed to provide a fixed or movable beam of light to illuminate the area around the vehicle or the vehicle itself</i>
Rear-registration-plate illumination lamps	Alley lamps <i>Work lamps designed primarily to provide a fixed or movable beam of light to the side of the vehicle it is fitted to</i>
Rear reflectors	Flashing or revolving beacons
Fog lamps	Illuminated vehicle-mounted signs
Daytime running lamps	<i>Includes PSV destination signs, taxi signs and variable message signs operated by enforcement officers, under a traffic management plan or permitted by other legislation</i>
Cornering lamps	
Reversing lamps	
PSV interior lamps	

Note 1 A rear or side cosmetic lamp that does not comply with requirements for condition or performance must be made to comply, or be disabled so that it does not emit a light.

Note 2 A forward-facing cosmetic lamp fitted to a class NC vehicle first registered in New Zealand before 27 February 2005 that does not comply with the equipment, condition and performance requirements, must be made to comply or be disabled so that it does not emit a light. All other forward-facing cosmetic lamps that do not comply must be made to comply or be removed from the vehicle.

Note 3 Definitions

Lamp means a device designed to emit light, and includes an array of separate light sources that appear as a continuous illuminated surface.

Cosmetic lamp means any lamp that is not listed in **Table 4-15-1**.

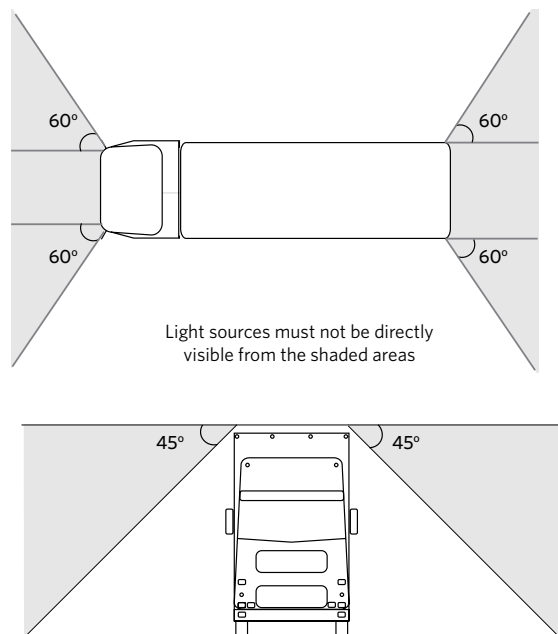

Figure 4-15-1. Visibility angles for cosmetic lamps

Lighting**4-16 PSV audible and visible reversing warning devices****Summary of legislation****Applicable legislation**

- Land Transport Rule: Passenger Service Vehicles 1999

Mandatory equipment

1. A heavy motor vehicle that can carry more than 12 persons, which entered service on or after 1 July 2000, must be fitted with a device that operates when the reverse gear is engaged and the engine is running, and which gives an audible and visible external warning when the vehicle is reversing.

Reasons for rejection**Mandatory equipment**

1. A heavy motor vehicle that can carry 13 or more persons, which entered service on or after 1 July 2000, is not fitted with a reversing warning device that operates when the reverse gear is engaged and the engine is running.

Condition and performance

2. With reverse gear engaged and the engine running, the reversing warning device does not give:
 - a) an audible external warning, or
 - b) a visible external warning (usually the reversing lamps).

Lighting

4-17 PSV interior lighting

Summary of legislation

Applicable legislation

- Land Transport Rule: Passenger Service Vehicles 1999

Condition and performance

1. Interior lights must be positioned so that they adequately illuminate doorways, aisles and steps, but without interfering with the driver's vision when the doors are closed.

Reasons for rejection

1. An interior light for the purpose of illuminating a doorway, aisle or step:
 - a) does not function, or
 - b) interferes with the driver's vision when the doors are closed.

Lighting

4-17 PSV interior lighting

Summary of legislation

Applicable legislation

- Land Transport Rule: Passenger Service Vehicles 1999

Condition and performance

1. Interior lights must be positioned so that they adequately illuminate doorways, aisles and steps, but without interfering with the driver's vision when the doors are closed.

Reasons for rejection

1. An interior light for the purpose of illuminating a doorway, aisle or step:
 - a) does not function, or
 - b) interferes with the driver's vision when the doors are closed.

