

Forklifts

1 Introduction

2 Vehicle exterior

2-1 External projections

2-2 Dimensions

3 Vehicle structure

3-1 Structure

4 Lighting

4-1 Headlamps

4-2 Front and rear fog lamps

4-3 Cornering lamps

4-4 Daytime running lamps

4-5 Direction indicator lamps

4-6 Forward-facing position lamps

4-7 Rearward-facing position lamps

4-8 Side-marker lamps

4-9 End-outline marker lamps

4-10 Stop lamps

4-11 High-mounted stop lamps

4-12 Rear registration-plate illumination lamps

4-13 Rear reflectors

4-14 Reversing lamps

4-15 Cosmetic lamps

5 Vision

5-1 Glazing

5-2 Sun visors

5-3 Windscreen wipe and wash

5-4 Rear-view mirrors

6 Entrance and exit

6-1 Door and hinged panel retention systems

7 Vehicle interior

7-1 Seats and seat anchorages

7-3 Head restraints

7-7 Interior impact

7-12 Speedometer

7-13 Audible warning devices

8 Brakes

8-1 Service brake and parking brake

9 Steering

9-1 Steering and suspension systems

10 Tyres, wheels and hubs

10-1 Tyres and wheels

10-2 Hubs and axles

10-3 Mudguards

11 Exhaust

11-1 Exhaust system

11-2 Visible exhaust smoke

12 Towing connections

12-1 Towing connections

13 Miscellaneous items

13-1 Engine and drive train

13-2 Fuel system

13-3 LPG/CNG fuel system

Forklifts 1 Introduction

Inspection and certification of forklifts: Warrant of fitness requirements

This section specifies the requirements that are applicable to the inspection and certification of forklifts for the purpose of issuing a warrant of fitness (WoF).

A forklift is defined as a motor vehicle (not fitted with self-laying tracks) designed principally for lifting, carrying and stacking goods by means of one or more tines, platens or clamps.

General requirements

1. A forklift that is operated on the road, ie that is registered, requires a WoF. Therefore, the vehicle inspector may inspect a forklift only if it has a registration plate attached to it.
2. Forklifts are required to comply with WoF requirements only as far as is practicable for their design and type. The requirements in this section are what the NZTA considers to be practicable in relation to the inspection and certification of forklifts.
3. Modifications that affect a safety requirement do not require low volume vehicle (LVV) or heavy vehicle specialist (HVS) certification unless specified otherwise. However, if the vehicle inspector has concerns about the modification, they must obtain additional information from a relevant person before passing the vehicle for WoF.
4. A forklift is not required to have a permanent vehicle identifier. If the forklift has a permanent vehicle identifier, such as the manufacturer's serial number, it must be recorded on the checksheet and on the NZTA computer system.
5. This section applies to both light and heavy forklifts. Heavy forklifts, that is those with a gross vehicle mass (GVM) greater than 3500 kg, may be inspected and certified for a WoF only if the inspecting organisation and vehicle inspector have current 'Heavy vehicle, exempt from CoF' authorisation.
6. For the purpose of this section, the GVM can generally be determined by adding the unladen weight of the forklift (including fuel in the fuel system and any equipment and accessories necessary to operate the forklift), the crew and the forklift's lifting capacity.

Vehicle exterior

2-1 External projections

Summary of legislation

Applicable legislation

- Land Transport Rule: External Projections 2001

Permitted equipment

1. A forklift may be fitted with a protruding ornamental or functional object or fitting.

Condition and performance

2. A protruding ornamental object or fitting must not be likely to injure a person.
3. A protruding object or fitting that has a functional purpose must be installed so that the risk of the object or fitting causing injury to a person is minimised.
4. Components of a forklift, including damaged or corroded body panels, must be such that the risk of their hooking a vehicle, or hooking or grazing a person, is minimised.
5. A protruding object or fitting must not adversely affect driver vision or driver control.

Reasons for rejection

Condition and performance

1. The risk of a component (**Note 1**) hooking a vehicle, or hooking or grazing a person, has not been minimised.
2. An ornamental object or fitting (**Note 2**) protrudes in such a way that it is likely to injure a person.
3. A protruding object or fitting that has a functional purpose (**Note 2**) is fitted in a way that does not reduce the risk of injury to a person.
4. A component, object or fitting is not securely attached to the vehicle.
5. A protruding object or fitting adversely affects the driver's vision or control.

Note 1 Components include damaged, corroded and exposed body panels.

Note 2 Definitions

The external projections requirements relate to the design and maintenance of objects and fittings that protrude from the exterior of the motor vehicle with regard to the safety of other motor vehicles, pedestrians and cyclists.

Ornamental object or fitting means an object or fitting that does not have a practical purpose, eg bonnet emblems.

Functional object or fitting means an object or fitting that has a practical purpose.

Vehicle exterior 2-2 Dimensions

Summary of legislation

Applicable legislation

- Land Transport Rule: Vehicle Dimensions and Mass 2002

Mandatory equipment

- A forklift that exceeds the dimensions in **Table 2-2-1** must be fitted with additional equipment set out in **Table 2-2-2**.

Reasons for rejection

Mandatory equipment

- A forklift exceeds the dimension requirements set out in **Table 2-2-1** and is not fitted with the appropriate hazard warning equipment set out in **Table 2-2-2**.
- A required revolving amber beacon cannot be activated and deactivated.

Table 2-2-1. Dimension requirements (see Figure 2-2-4)

Dimension	Maximum distance	Comments
Width	2.5 m	Measurement does not include: <ul style="list-style-type: none"> collapsible mirrors which extend no more than 240 mm from the body direction indicators and side-marker lamps cab exterior grab rails that extend no more than 50 mm from the side of the body ropes, lashings, straps, chains and related connectors and tensioning devices that extend no more than 25 mm from either side, and that are not permanently or rigidly fixed to the vehicle the bulge towards the bottom of a tyre.
Overall length	12.6 m (no tow coupling fitted) 11.5 m (tow coupling fitted)	Measurement does not include collapsible mirrors.
Height	4.25 m	Measurement does not include load restraining devices (ropes, lashings, straps, chains, covers and related connectors and tensioning devices) that extend no more than 25 mm above the vehicle, and that are not permanently or rigidly fixed to the vehicle.
Forward distance	8.5 m (tow coupling fitted) 9.5 m (no tow coupling fitted)	<ul style="list-style-type: none"> Measured from the rear axis (Note 1) to the front of the vehicle Measurement does not include collapsible mirrors
Rear overhang	Forklift GVM 3500 kg or less: <ul style="list-style-type: none"> 4 m Forklift GVM greater than 3500 kg: <ul style="list-style-type: none"> with rearmost axle being a non-steering axle: 4 m or 70% of wheelbase (whichever is less) with rearmost axle being a steering axle: 4.25 m or 70% of wheelbase (whichever is less) 	<ul style="list-style-type: none"> Rear overhang is measured from the rear axis (Note 1) to the rear of the vehicle
Front overhang	3 m	<ul style="list-style-type: none"> Front overhang is measured from the front edge of the driver's seat in the rearmost position to the front of the vehicle.

Vehicle exterior

2-2 Dimensions (cont.)

Table 2-2-2. Hazard warning equipment requirements for vehicles that exceed the dimensions in Table 2-2-1

Vehicle category	Dimension	Limits (up to and including)	Required hazard warning equipment
Category 1	Width/forward distance (see Figure 2-2-3) Length Front overhang Rear overhang	2.5 m/11.4 m, or 3.1 m/10.5 m, or 3.7 m/8.5 m, or 25 m, or 7 m, or 7 m	Flags ¹ or panels ² fitted on each side at the front and rear
Category 2 (not including category 1)	Width/forward distance (see Figure 2-2-3) Length Front overhang Rear overhang	2.5 m/13.3 m, or 4.5 m/8.5 m, or 35 m 10 m, or 10 m	<ol style="list-style-type: none"> 1. Panels² fitted on each side at the front and rear 2. OVERSIZE sign³ fitted at the front and rear if more than 3.1 m wide 3. Revolving amber beacon fitted to the cab roof if more than 3.7 m wide
Category 3 (not including category 2)	Width/forward distance (see Figure 2-2-3)	2.5 m/20 m 5 m/20 m 5 m/8.5 m	<ol style="list-style-type: none"> 1. Panels² fitted on each side at the front and rear 2. OVERSIZE sign³ fitted at the front and rear if more than 3.1 m wide 3. Revolving amber beacon fitted to the cab roof if more than 3.7 m wide
Category 4 (not including category 3)	Width/forward distance (see Figure 2-2-3)	11 m/20 m 11 m/8.5 m	<ol style="list-style-type: none"> 1. Panels² fitted on each side at the front and rear 2. OVERSIZE sign³ fitted at the front and rear if more than 3.1 m wide 3. Revolving amber beacon fitted to the cab roof if more than 3.7 m wide

1 Flags:

- must be fluorescent yellow
- must be at least 400 mm long × 300 mm wide.

2 Hazard warning panels

- must be reflective yellow-green with a reflective orange diagonal stripe
- must be of at least of the minimum dimensions and of the colours specified in **Figure 2-2-1**:

3 OVERSIZE sign

- must be black lettering on a yellow-green background
- must be at least 300 mm × 1100 mm in size
- may be in two parts: OVER and SIZE.

Note 1 Definitions

The **rear axis**

- a) in relation to a vehicle with only one non-steering axle, means that axle,
- b) in relation to a vehicle with a non-steering axle set of two axles, means:

- i. midway between those axles, if each axle has an equal number of tyres on it, or
 - ii. two-thirds of the distance from the lesser-tyred axle towards the greater-tyred axle, if one axle has twice as many tyres on it as the other axle
- c) in relation to a vehicle with a non-steering tri-axle set or a non-steering quad-axle set, or an overdimension vehicle with more than three axles, means midway between the extreme axles of the set
- d) in relation to a vehicle whose rear axle set includes one or more steerable axles in conjunction with one or more non-steering axles, means midway between the extreme non-steering axles of the set.

Front axis means the centre of the foremost axle of a rigid vehicle with motive power.

Wheelbase means the distance from a vehicle's rear axis to its front axis.

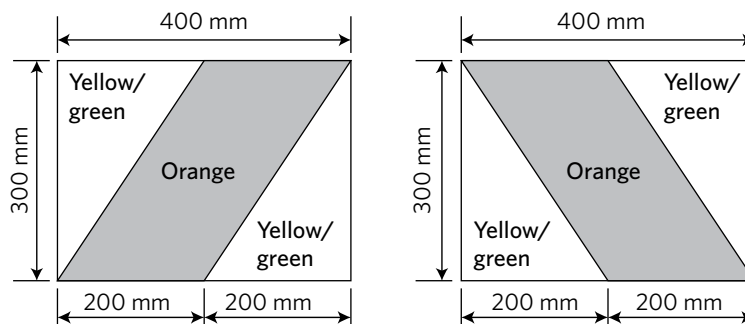

Figure 2-2-1. Hazard panel details

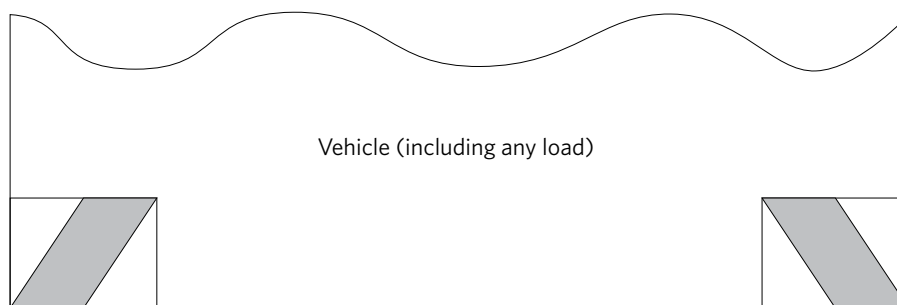

Figure 2-2-2. Hazard panel location and orientation

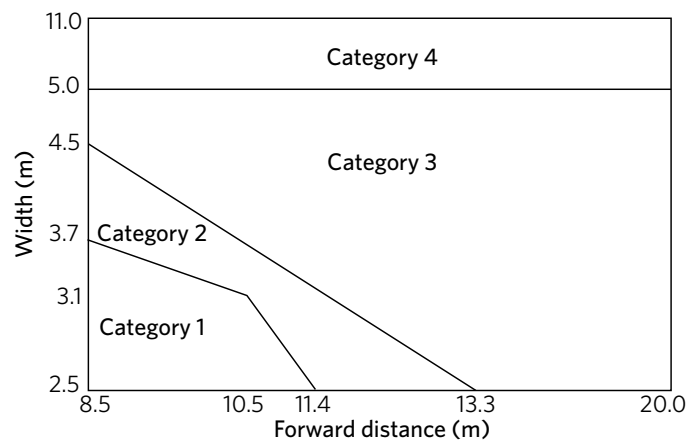

Figure 2-2-3. Overdimension vehicle categories for width/forward distance thresholds

Use this figure to determine vehicle category in **Table 2-2-2**

Vehicle exterior

2-2 Dimensions (cont.)

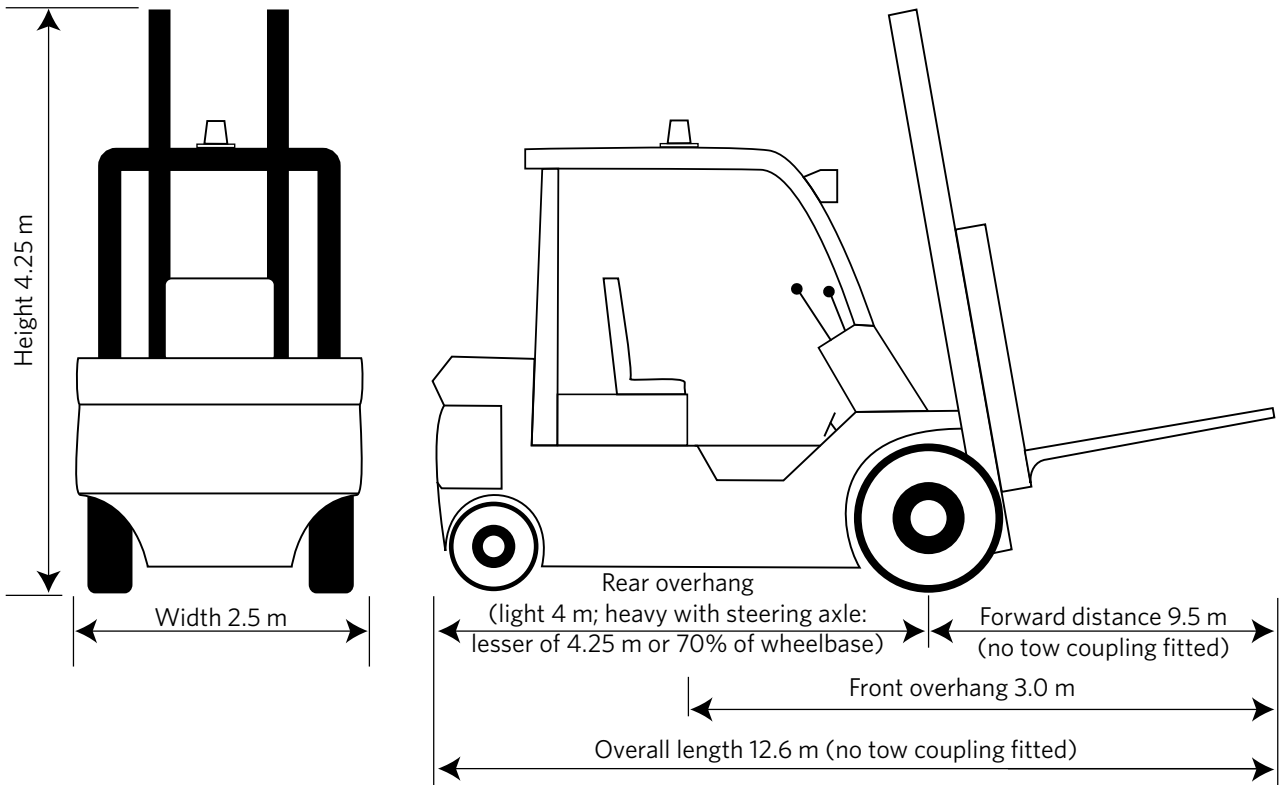

Figure 2-2-4. Dimension requirements

Vehicle structure

3-1 Structure

Summary of legislation

Applicable legislation

- Land Transport Rule: Vehicle Standards Compliance 2002, clause 7.4

Condition

- The forklift must be safe to be operated.
- The components and materials must be fit for their purpose and within safe tolerance of their state when manufactured or modified.

Reasons for rejection

Condition

- The structure of the forklift has visible:
 - deformation from the original shape that has affected the vehicle's structural integrity (**Note 1** and **Note 3**), or
 - cracking, or
 - fracture, or
 - any corrosion, damage or repair that the inspector considers has caused weakening of a load-bearing structure.
- A rollover protection structure, or overhead protection structure or cab is not securely attached to the forklift.

Note 1 The structural inspection of a forklift does not include the occupant safety frame, except for its attachment to the vehicle body or chassis.

Note 2 Corrosion damage is where the metal has been eaten away, which is evident by pitting. The outward sign of such corrosion damage is typically displayed by the lifting or bubbling of paint. In extreme cases, the area affected by the corrosion damage will fall out and leave a hole.

Note 3 The vehicle inspector may request additional relevant information from a repairer or other relevant person. The vehicle inspector should withhold the WoF if there is reason to believe that the vehicle has:

- structural damage, or
- inadequate structural repair(s), or
- corrosion damage

to the extent that it could affect the vehicle's structural strength or one of the vehicle's safety requirements. If the owner questions the decision, the vehicle inspector should recommend the vehicle owner obtain further written assessment from the equipment manufacturer or other suitable person.

Lighting 4-1 Headlamps

Summary of legislation

Applicable legislation

- Land Transport Rule: Vehicle Lighting 2004

Mandatory and permitted equipment (Note 6)

- A forklift:
 - must be fitted with:
 - one pair of dipped-beam headlamps, or
 - one pair of forward-facing work lamps (**Note 1**).
- A forklift may be fitted with one or two pairs of main-beam headlamps.
- A warning device may be fitted that indicates that the main-beam headlamps are switched on.
- A retrofitted pair of headlamps must be symmetrically mounted as far towards each side of the vehicle as is practicable.

Prohibited equipment

- A dipped-beam headlamp designed solely for a left-hand drive vehicle, where the maximum intensity of the beam is dispersed to the right, must not be fitted.

Condition

- A headlamp or a mandatory forward-facing work lamp must:
 - be in sound condition, and
 - not be obscured.

Performance

- A lamp must operate in a way that is appropriate for the lamp and the vehicle.
- A lamp must emit a steady light.
- A lamp must provide sufficient illumination and light output to illuminate the road ahead.
- A pair of lamps must emit light that is approximately of equal colour and intensity when switched on.
- A lamp must emit a beam that is substantially white or amber.
- A main-beam headlamp must be capable of being dipped or turned off from the driver's position.
- A warning device that indicates that the main-beam lamps are in operation must be in good working order.
- When the headlamps are switched on and the vehicle's front wheels are pointing in the straight-ahead position:
 - the centre of a headlamp beam must be either parallel to or to the left of the longitudinal centreline of the vehicle, and

Reasons for rejection

Mandatory and permitted equipment (Note 6)

- A forklift is not fitted with either:
 - one pair of dipped-beam headlamps, or
 - one pair of forward-facing work lamps (**Note 1**).
- A forklift is fitted with more than:
 - one pair of dipped-beam headlamps, or
 - two pairs of main-beam headlamps.
- A forklift is fitted with a headlamp that is not in a pair.
- A retrofitted pair of headlamps is:
 - not fitted symmetrically, or
 - not fitted as far towards each side of the vehicle as is practicable.
- A forklift is fitted with a dipped-beam headlamp where the maximum intensity of the beam is projected to the right.

Condition

- A lamp is insecure, or contains visible moisture or dirt.
- A lens is missing or has a hole, crack or other damage that allows moisture or dirt to enter.
- A reflector is damaged or has deteriorated so that light output is reduced.
- A mandatory lamp is obscured.
- A main-beam headlamp warning device is obscured from the driver's vision.

Performance

- When switched on, a headlamp emits a light that is:
 - not substantially white or amber, or
 - not approximately equal in colour or intensity to the other lamp in a pair, or
 - not steady, or
 - not bright enough to illuminate the road ahead, eg due to modification, deterioration or an incorrect light source, or

Lighting

4-1 Headlamps (cont.)

- b) the centre of a main-beam headlamp beam must be either parallel to or dipping down from the horizontal and
 - c) the centre of a dipped-beam headlamp beam must dip at an angle specified in **Table 4-1-1**.
15. The dipped-beam headlamps must illuminate the road ahead for 50 m in normal darkness.
 16. A headlamp must be fitted with a light source that is specified by the vehicle manufacturer or the headlamp manufacturer.

Reasons for rejection

- e) too bright, causing significant dazzle to other road users, eg due to an incorrect light source.
11. When the dipped-beam headlamps are switched on (with wheels pointing straight ahead):
 - a) a lamp does not operate, or
 - b) more than two lamps operate on dipped beam, or
 - c) the light beam produces an incorrect beam pattern, is not focused, or is reduced or altered, or
 - d) the centreline of the light beam is too far to the left or slopes down too far so that the headlamp is no longer capable of illuminating the road at least 50 m ahead (**Figure 4-1-1**), or
 - e) the centreline of the light beam:
 - i. projects to the right of the vehicle's centreline, or
 - ii. does not dip at an angle specified in **Table 4-1-1**.
 12. When the main-beam headlamps are switched on (with wheels pointing straight ahead):
 - a) a lamp does not operate, or
 - b) more than four lamps operate on main beam, or
 - c) the centreline of the light beam projects to the right of the vehicle's centreline or up from the horizontal, or
 - d) the lamps are not capable of being switched to dipped beam or turned off from the driver's seating position, or
 - e) a main-beam headlamp warning device does not indicate to the driver that the main-beam headlamps are switched on.
 13. On a forklift with no headlamps, when the forward-facing work lamps are switched on a mandatory lamp does not operate.
 14. On a forklift with no headlamps, when the forward-facing work lamps are switched on a lamp emits a light that is:
 - a) not substantially white or amber, or

Reasons for rejection

- b) not approximately equal in colour or intensity to the other lamp in a pair, or
- c) not steady, or
- d) not bright enough to illuminate the road ahead, eg due to modification, deterioration or an incorrect light source, or
- e) dazzling to other road users, eg due to inappropriate alignment (**Figure 4-1-8**).

Table 4-1-1. Allowable dipped-beam headlamp alignment

	Headlamp type	Distance from ground to centre of light source	Dip rate of beam centre: lower and upper limits		
			Percent (%)	mm/3 m	Degrees (°)
EITHER	Any headlamp dipped beam	N/A	As specified by the vehicle or headlamp manufacturer		
OR	Headlamp with symmetric dipped-beam pattern	N/A	3.0-3.5	90-105	1.7-2.0
OR	Headlamp with asymmetric dipped-beam pattern and distance from ground to centre of light source	less than 0.8 m	1.0-1.5	30-45	0.57-0.85
		0.8-1.2 m	1.0-2.0	30-60	0.57-1.15
		more than 1.2 m	2.0-2.5	60-75	1.15-1.43

Table 4-1-2. Dipped-beam angle conversions

Percent (%)	mm/3 m	Degrees (°)
1.0	30	0.6
1.1	33	0.6
1.2	36	0.7
1.3	39	0.7
1.4	42	0.8
1.5	45	0.9
1.6	48	0.9
1.7	51	1.0
1.8	54	1.0
1.9	57	1.1
2.0	60	1.1
2.1	63	1.2
2.2	66	1.3

Percent (%)	mm/3 m	Degrees (°)
2.3	69	1.3
2.4	72	1.4
2.5	75	1.4
2.6	78	1.5
2.7	81	1.5
2.8	84	1.6
2.9	87	1.7
3.0	90	1.7
3.1	93	1.8
3.2	96	1.8
3.3	99	1.9
3.4	102	1.9
3.5	105	2.0

Lighting 4-1 Headlamps (cont.)

Note 1 Definitions

Work lamp means a high-intensity lamp, which is not necessary for the operation of the vehicle but is designed to illuminate a work area or scene, and includes a scene lamp, a spot lamp and an alley lamp. In the case of a forklift without headlamps, forward-facing work lamps must be fitted to illuminate the road ahead during the hours of darkness.

Headlamp means a lamp designed to illuminate the road ahead of a vehicle, and that is a:

- a) dipped-beam headlamp (single lamp), or
- b) main-beam (high-beam) headlamp (single lamp), and includes a driving lamp, or
- c) combination of a dipped-beam headlamp and a main-beam headlamp (dual-lamp unit).

Note 2 If the dipped-beam headlamps are able to be adjusted from the driver's seating position, the alignment must be checked with the adjustment at its highest position.

Note 3 If the vehicle is fitted with self-levelling suspension, the alignment must be checked with the suspension at its normal level.

Note 4 If a headlamp is fitted with a readily removable cover, other than a clear protective cover, this must be removed for inspection of the headlamp.

Note 5 A vehicle originally manufactured with a headlamp arrangement that differs from what is required or permitted in this section may retain the original headlamps provided they remain fitted in their original position and perform as intended by the vehicle manufacturer.

Note 6 A forklift that has no or non-compliant headlamps may be issued with a WoF provided the forklift:

- a) complies with all other applicable WoF requirements, and
- b) is not operated during the hours of darkness.

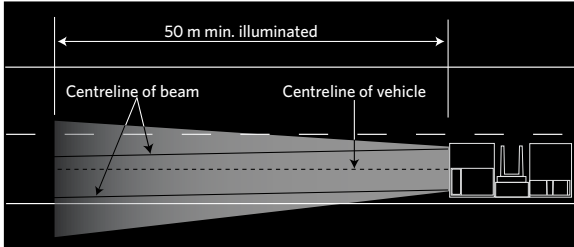

Figure 4-1-1. Minimum illuminated area

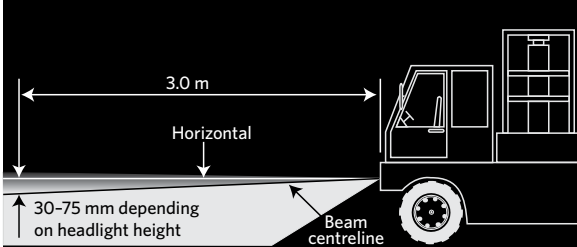

Figure 4-1-2. Asymmetric dipped beam

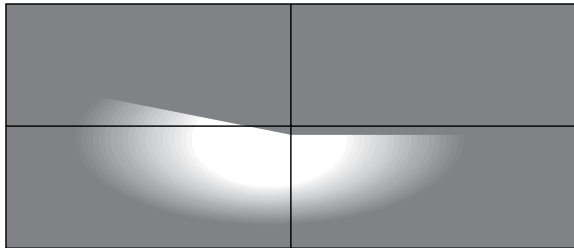

Figure 4-1-3. Asymmetric dipped-beam headlamp pattern on light board

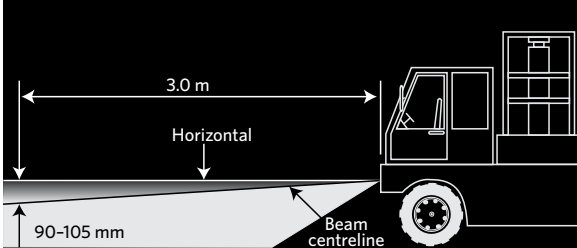

Figure 4-1-4. Symmetric dipped beam

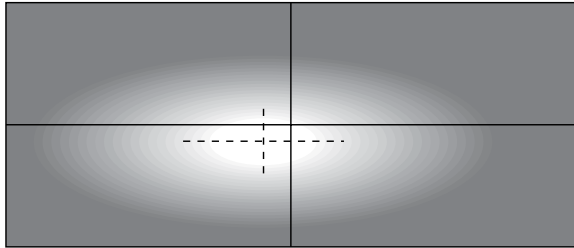

Figure 4-1-5. Symmetric dipped-beam headlamp pattern on light board

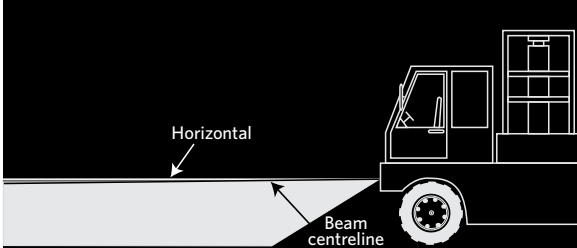

Figure 4-1-6. Main (high) beam

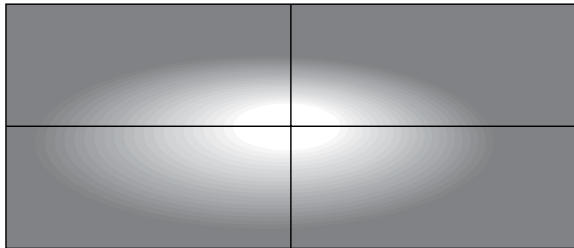

Figure 4-1-7. Main- (high-) beam headlamp pattern on light board

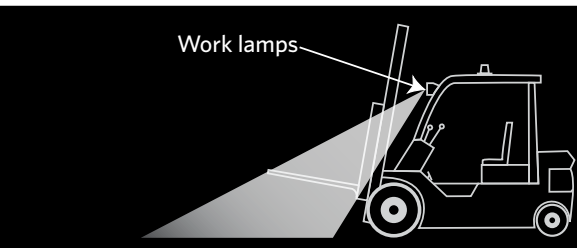

Figure 4-1-8. Work lamp beam pattern

Lighting 4-2 Front and rear fog lamps

Summary of legislation

Applicable legislation

- Land Transport Rule: Vehicle Lighting 2004

Permitted equipment

1. A forklift may be fitted with:
 - a) one pair of front fog lamps, and
 - b) one or two rear fog lamps.
2. A retrofitted pair of fog lamps must be symmetrically mounted as far as is practicable towards each side of the vehicle.
3. A retrofitted front fog lamp must not be positioned higher than the dipped-beam headlamps.
4. A vehicle may be fitted with a warning device that indicates that a front or rear fog lamp is in operation.

Condition

5. A front fog lamp must be in sound condition.
6. A rear fog lamp must be in sound condition if it emits a light.
7. A fog lamp must not be obscured.

Performance

8. A fog lamp must operate in a way that is appropriate for the lamp and the vehicle.
9. A fog lamp must emit a steady light.
10. A front fog lamp must provide sufficient light output to illuminate the road ahead in conditions of severely reduced visibility.
11. A rear fog lamp must provide sufficient light output to indicate the presence of the vehicle on the road in conditions of severely reduced visibility.
12. The light emitted from a front fog lamp must be substantially white or amber.
13. The light emitted from a rear fog lamp must be diffuse and substantially red in colour.
14. A pair of fog lamps must emit light that is approximately equal in colour and intensity.
15. The centre of a front fog lamp beam must be parallel to or to the left of the longitudinal centreline of the vehicle.
16. The centre of a front fog lamp beam must be permanently dipped at an angle of at least 3%.
17. A fog lamp must be able to be turned off from the driver's seating position.
18. A front or rear fog lamp warning device must be in good working order.
19. Where a fog lamp comprises an array of light sources (eg LEDs), at least 75% of these must operate.

Reasons for rejection

Permitted equipment

1. A forklift is fitted with:
 - a) only one front fog lamp, or
 - b) more than one pair of front fog lamps.
2. A forklift is fitted with more than two rear fog lamps.
3. A retrofitted pair of fog lamps is:
 - a) not fitted symmetrically, or
 - b) not fitted as far towards each side of the vehicle as is practicable, or
 - c) positioned higher than the dipped-beam headlamps.

Condition

4. A lamp is insecure, obscured or contains visible moisture or dirt.
5. A lens is missing or has a hole, crack or other damage that allows moisture or dirt to enter.
6. A reflector is damaged or has deteriorated so that light output is reduced.
7. A fog lamp warning device, if fitted, is obscured from the driver's vision.

Performance

8. When switched on, a front fog lamp does not operate.
9. When switched on, a front fog lamp emits light that:
 - a) is not projected to the front, or
 - b) produces an incorrect beam pattern (**Figure 4-2-1**), or
 - c) is not substantially white or amber to the front, or
 - d) is not approximately equal in colour or intensity to the other lamp in the pair, or
 - e) is not steady, or
 - f) is not bright enough to illuminate the road ahead in conditions of severely reduced visibility, eg due to modification, deterioration or an incorrect light source, or

Reasons for rejection

- g) is too bright, and could dazzle other road users, eg due to an incorrect light source, or
 - h) has a beam centre to the right of the vehicle's centreline, or
 - i) has a beam that is not permanently dipped, or
 - j) has a beam centre that dips at an angle of less than 3% (**Figure 4-2-1**).
10. When switched on, a rear fog lamp emits light that is not:
- a) projected to the rear, or
 - b) diffuse, or
 - c) substantially red, or
 - d) approximately equal in colour or intensity to the other lamp in a pair, or
 - e) steady, or
 - f) bright enough to indicate the presence of the vehicle from the rear in conditions of severely reduced visibility, eg due to modification, deterioration or an incorrect light source.
11. A fog lamp cannot be switched off from the driver's seating position.
12. Where a fog lamp comprises an array of light sources (eg LEDs), fewer than 75% of these operate.
13. A fog lamp warning device, if fitted, does not operate.

Note 1 Fog lamp means a front or rear lamp designed to aid the driver or other road users in conditions of severely reduced visibility, including fog or snow, but not including clear atmospheric conditions under the hours of darkness.

Note 2 A rear fog lamp that does not comply with equipment, condition and performance requirements must be made to comply or be disabled so that it does not emit a light.

Note 3 If a front fog lamp is fitted with a readily removable cover, other than a clear protective cover, this must be removed for inspection of the fog lamp.

Note 4 A vehicle originally manufactured with a front- or rear-fog lamp arrangement that differs from what is required or permitted in this section may retain the original front or rear fog lamps provided they remain fitted in their original position and perform as intended by the vehicle manufacturer.

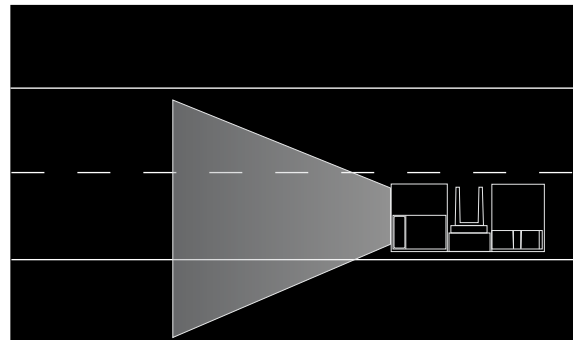

(a) Pattern on the road

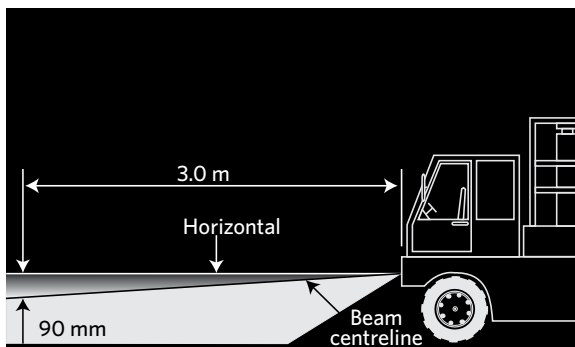

(b) Beam dip angle

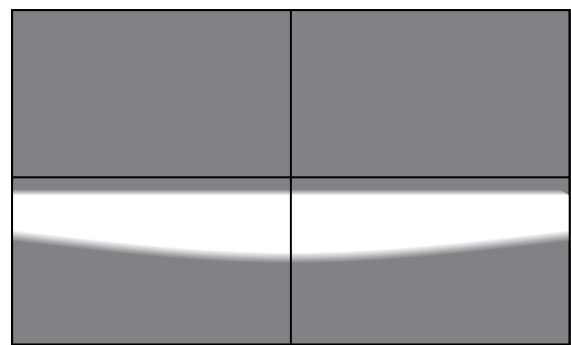

(c) Pattern on light board

Figure 4-2-1. Front fog lamp characteristics

Lighting 4-3 Cornering lamps

Summary of legislation

Applicable legislation

- Land Transport Rule: Vehicle Lighting 2004

Permitted equipment

1. One pair of cornering lamps fitted by the forklift manufacturer.

Condition

2. A cornering lamp must be in sound condition.

Performance

3. A cornering lamp must operate in a way that is appropriate for the lamp and the vehicle.
4. A cornering lamp must emit light that is substantially white or amber.
5. A pair of cornering lamps must emit light that is approximately equal in colour and intensity.
6. A cornering lamp must emit a steady light.
7. A cornering lamp must provide sufficient light output to illuminate the road ahead in the direction of the turn.
8. A cornering lamp must be correctly aligned.
9. Where a cornering lamp comprises an array of light sources (eg LEDs), at least 75% of these must operate.

Reasons for rejection

Permitted equipment

1. A forklift is fitted with:
 - a) only one lamp, or
 - b) more than one pair of lamps, or
 - c) a lamp that either:
 - i. was not originally fitted by the forklift manufacturer, or
 - ii. is not fitted in the original position.

Condition

2. A lamp is insecure or contains visible moisture or dirt.
3. A lens is missing, or has a hole, crack or other damage that allows moisture or dirt to enter.
4. A lamp's reflector is damaged or has deteriorated so that light output is reduced.

Performance

5. When activated by switching on the direction indicator lamp or by turning the steering wheel, a cornering lamp does not:
 - a) operate, or
 - b) project in the direction of the turn.
6. A cornering lamp emits light that is:
 - a) not substantially white or amber, or
 - b) not approximately equal in colour or intensity to the other lamp in a pair, or
 - c) not steady, or
 - d) not bright enough to illuminate the road ahead in the direction of the turn, eg due to modification, deterioration or an incorrect light source, or
 - e) too bright, causing dazzle to other road users, eg due to an incorrect light source or misalignment.
7. Where a cornering lamp comprises an array of light sources (eg LEDs), fewer than 75% of these operate.

Note 1 **Cornering lamp** means a lamp that is designed to emit light at the front of a vehicle to supplement the vehicle's headlamps by illuminating the road ahead in the direction of the turn.

Lighting

4-4 Daytime running lamps

Summary of legislation

Applicable legislation

- Land Transport Rule: Vehicle Lighting 2004

Prohibited equipment

1. A forklift must not be fitted with daytime running lamps.

Reasons for rejection

Prohibited equipment

1. A forklift is fitted with daytime running lamps.

Note 1 Daytime running lamp means a lamp designed to emit a low-intensity light forward of a vehicle to make it more easily seen in the daytime.

Lighting 4-5 Direction indicator lamps

Summary of legislation

Applicable legislation

- Land Transport Rule: Vehicle Lighting 2004

Permitted equipment

1. A forklift may be fitted with one or two pairs of lamps to the front and rear of the vehicle.
2. A forklift may be fitted with one or two side-facing lamps on each side.
3. A suitable device may be fitted that indicates to the driver the failure of a mandatory lamp.
4. A retrofitted pair of lamps must be mounted symmetrically as far towards each side of the forklift as is practicable.
5. On forklifts of American origin, the stop lamp and direction indicator lamp function may be combined in one lamp.

Condition

6. A direction indicator lamp must:
 - a) be in sound condition, and
 - b) not be obscured.

Performance

7. A direction indicator lamp must operate in a way that is appropriate for the lamp and the vehicle.
8. A direction indicator lamp must emit a light that is substantially:
 - a) red or amber to the rear, and
 - b) white or amber to the front, and
 - c) amber to the side.
9. A lamp must flash at a fixed frequency in the range of 1 to 2 Hertz.
10. Each lamp in a pair must, when operated, emit a light of approximately equal intensity, colour and frequency.
11. The lamp-failure indicating device, if fitted, must function.
12. A lamp must emit a light that is visible from 100 m during normal daylight and 200 m in normal darkness.
13. If a vehicle of American origin is fitted with combined stop and indicator lamps, the indicator lamps may override the stop lamps so that the stop lamps operate as direction indicators.
14. Where a lamp comprises an array of light sources (eg LEDs), at least 75% of these must operate.

Reasons for rejection

Permitted equipment

1. A forklift is fitted with more than:
 - a) two pairs of lamps at the rear, or
 - b) two pairs of lamps at the front, or
 - c) two side-facing lamps on each side.
2. A forklift is fitted with a lamp that is not in a pair.
3. A retrofitted pair of lamps is not:
 - a) symmetrically mounted, or
 - b) mounted as far towards each side of the forklift as is practicable.

Condition

4. A lamp is insecure, obscured or contains visible moisture or dirt.
5. A lens is missing, or has a hole, crack or other damage that allows moisture or dirt to enter.
6. A reflector is damaged or has deteriorated so that light output is reduced.

Performance (Note 2)

7. When switched on, a direction indicator lamp:
 - a) does not operate, or
 - b) does not begin flashing within one second of switching on, or
 - c) flashes:
 - i. faster than two flashes per second, or
 - ii. slower than one flash per second, or
 - iii. at a different rate from other lamps on the same side.
8. When switched on, a direction indicator lamp emits a light that is:
 - a) not substantially amber or red to the rear, or
 - b) not substantially white or amber to the front, or
 - c) not substantially amber to the side, or

Reasons for rejection

- d) not approximately equal in colour or intensity to the other lamp in a pair, or
 - e) not bright enough to be visible from 100 m in normal daylight and from 200 m in normal darkness, eg due to modification, deterioration or an incorrect light source, or
 - f) too bright causing significant dazzle to other road users, eg due to an incorrect light source, or
 - g) altered, eg due to damage or modification.
11. On a forklift of American origin fitted with combined stop and indicator lamps, the stop lamp function is not overridden by the indicator function.
 12. Where a lamp comprises an array of light sources (eg LEDs), fewer than 75% of these operate.

Note 1 **Direction indicator lamp** means a lamp designed to emit a flashing light to signal the intention of the driver to change the direction of the vehicle to the right or to the left.

Note 2 A rear- or side-facing direction indicator lamp that does not comply with equipment, condition and performance requirements must be made to comply or disabled so that it does not emit a light.

Note 3 A vehicle originally manufactured with a direction-indicator-lamp arrangement that differs from what is required or permitted in this section may retain the original direction indicator lamps provided they remain fitted in their original position and perform as intended by the vehicle manufacturer.

Lighting 4-6 Forward-facing position lamps

Summary of legislation

Applicable legislation

- Land Transport Rule: Vehicle Lighting 2004

Permitted equipment

1. A forklift may be fitted with one or two pairs of forward-facing position lamps.
2. A forklift exceeding 2 m in width must be fitted with one pair of lamps.
3. A retrofitted pair of lamps must be symmetrically mounted as far towards each side of the vehicle as is practicable.
4. A retrofitted lamp must be mounted at a height from the ground not exceeding 2.1 m.
5. A forklift may be fitted with one additional pair of forward-facing position lamps that must be symmetrically mounted as far towards the top corners of the vehicle as is practicable (top-mounted lamps).
6. A lamp must be positioned to the front of the vehicle.

Condition

5. A forward-facing position lamp must:
 - a) be in sound condition.
 - b) not be obscured.

Performance

6. A forward-facing position lamp must operate in a way that is appropriate for the lamp and the vehicle.
7. A lamp must emit a light that is:
 - a) diffuse, and
 - b) substantially white or amber, and
 - c) steady, and
 - d) sufficient to indicate to other road users the presence and dimensions of the vehicle, and
 - e) visible from 200 m in normal darkness, and
 - f) of approximately equal intensity and colour to the other lamp of a pair.
8. Where a lamp comprises an array of light sources (eg LEDs), at least 75% of these must operate.

Reasons for rejection

Permitted equipment

1. A forklift is fitted with more than two pairs of lamps.
2. A forklift exceeding 2 m in width is not fitted with one pair of lamps.
3. A retrofitted pair of lamps is not:
 - a) symmetrically mounted, or
 - b) mounted as far towards each side of the vehicle as is practicable.
4. A retrofitted lamp is mounted at a height from the ground exceeding 2.1 m.
5. A pair of top-mounted lamps, if fitted, is not:
 - a) symmetrically mounted, or
 - b) mounted as far towards the top corners of the bodywork as is practicable.
6. A lamp is not positioned to the front of the vehicle.

Condition

7. A lamp is insecure or contains visible moisture or dirt.
8. A lens is missing, or has a hole, crack or other damage that allows moisture or dirt to enter.
9. A lamp's reflector is damaged or has deteriorated so that light output is reduced.

Performance

10. When switched on, a forward-facing position lamp does not operate.
11. When switched on, a forward-facing position lamp emits a light that is not:
 - a) substantially white or amber, or
 - b) diffuse, or
 - c) projected to the front, or
 - d) approximately equal in colour or intensity to the other lamp in a pair, or
 - e) steady, or
 - f) bright enough to be visible from 200 m in normal darkness, eg due to modification, deterioration or an incorrect light source.

Lighting

4-6 Forward-facing position lamps (cont.)

Note 1 **Position lamp** means a low-intensity lamp that is designed to indicate to road users the presence and dimensions of a vehicle, being:

- a) a forward-facing position lamp (front side lamp), or
- b) a rearward-facing position lamp (rear side lamp or tail lamp), or
- c) a side-marker lamp, or
- d) an end-outline marker lamp (including cab roof lamp).

Note 2 A vehicle originally manufactured with a forward-facing position lamp arrangement that differs from what is required or permitted in this section may retain the original forward-facing position lamps provided they remain fitted in their original position and perform as intended by the vehicle manufacturer.

Lighting 4-7 Rearward-facing position lamps

Summary of legislation

Applicable legislation

- Land Transport Rule: Vehicle Lighting 2004

Mandatory and permitted equipment

1. A forklift first registered in New Zealand on or after 1 January 1978 and that is more than 1.5 m wide must be fitted with one or two pairs of rearward-facing position lamps.
2. A forklift that was first registered in New Zealand before 1 January 1978 or that does not exceed 1.5 m in width must be fitted with:
 - a) one single rearward-facing position lamp in the centre or to the right of the centre of the vehicle, or
 - b) one or two pairs of rearward-facing position lamps.
3. A retrofitted pair of lamps, other than top-mounted lamps, must be mounted:
 - a) symmetrically as far towards each side of the vehicle as is practicable, and
 - b) at a height from the ground not exceeding 2.1 m.
4. A forklift may be fitted with an additional pair of rearward-facing position lamps symmetrically mounted as far towards each side and top of the bodywork of the vehicle as possible (top-mounted lamps).
5. A lamp must be positioned to the rear of the vehicle.

Condition

6. A rearward-facing position lamp must:
 - a) be in sound condition, and
 - b) not be obscured.

Performance

7. A rearward-facing position lamp must operate in a way that is appropriate for the lamp and the vehicle.
8. A lamp must emit a light that is:
 - a) diffuse, and
 - b) substantially red, and
 - c) steady, and
 - d) sufficient to indicate to other road users the presence and dimensions of the vehicle, and
 - e) visible from a distance of 200 m in normal darkness, and
 - f) of approximately equal intensity and colour to the other lamp of the pair.
9. A retrofitted mandatory lamp must be visible within angles of 15° above and below the horizontal, and within 45° inboard and 80° outboard.
10. Where a lamp comprises an array of light sources (eg LEDs), at least 75% of these must operate.

Reasons for rejection

Mandatory and permitted equipment

1. A forklift first registered in New Zealand on or after 1 January 1978 that is more than 1.5 m wide:
 - a) is not fitted with one pair of lamps, or
 - b) is fitted with more than three pairs of lamps, or
 - c) is fitted with a lamp that is not in a pair.
2. A forklift first registered in New Zealand before 1 January 1978 or that is less than 1.5 m wide is:
 - a) not fitted with one pair of lamps, or
 - b) fitted with more than one single lamp, or
 - c) fitted with more than three pairs of lamps.
3. A retrofitted lamp, other than a top-mounted lamp, is mounted at a height from the ground exceeding 2.1 m.
4. A single lamp is fitted to the left of the centre of the vehicle.
5. A retrofitted pair of lamps is not:
 - a) symmetrically mounted, or
 - b) mounted as far towards each side of the vehicle as is practicable.
6. A pair of top-mounted lamps is not:
 - a) symmetrically mounted, or
 - b) mounted as far towards the top corners of the bodywork as is practicable.

Condition

7. A lamp is insecure, or contains visible moisture or dirt.
8. A lens is missing, or has a hole, crack or other damage that allows moisture or dirt to enter.
9. A lamp's reflector is damaged or has deteriorated so that light output is reduced.
10. A mandatory lamp is obscured.

Performance

11. When switched on, a mandatory lamp does not operate.

Reasons for rejection

12. When switched on, a lamp emits a light that is not:
 - a) substantially red, or
 - b) diffuse, or
 - c) projected to the rear, or
 - d) approximately equal in colour or intensity to the other lamp in a pair, or
 - e) steady, or
 - f) bright enough to be visible from 200 m in normal darkness, eg due to modification, deterioration or an incorrect light source.
13. A non-OE mandatory lamp mounted outside the original position emits a light that is not visible within:
 - a) 15° above and below the horizontal, or
 - b) 45° inboard or 80° outboard.
14. A modification to the vehicle has reduced the visibility angles of a mandatory lamp to less than (**Figure 4-7-1**):
 - a) 15° above and below the horizontal, or
 - b) 45° inboard or 80° outboard.
15. Where a lamp comprises an array of light sources (eg LEDs), fewer than 75% of these operate.

Note 1 Definition

Position lamp means a low-intensity lamp that is designed to indicate to road users the presence and dimensions of a vehicle, being:

- a) a forward-facing position lamp (front side lamp), or
- b) a rearward-facing position lamp (rear side lamp or tail lamp), or
- c) a side-marker lamp, or
- d) an end-outline marker lamp (including cab roof lamp).

Note 2 A permitted rearward-facing position lamp that does not comply with equipment, condition and performance requirements must be made to comply or be disabled so that it does not emit a light.

Note 3 An original equipment (OE) lamp is one that is fitted by the vehicle manufacturer in the original position, or is an equivalent replacement or aftermarket lamp suitable for the position provided by the vehicle manufacturer for that lamp. All other lamps are considered retrofitted (ie non-OE).

Note 4 A vehicle originally manufactured with a rearward-facing position lamp arrangement that differs from what is required or permitted in this section may retain the original rearward-facing position lamps provided they remain fitted in their original position and perform as intended by the vehicle manufacturer.

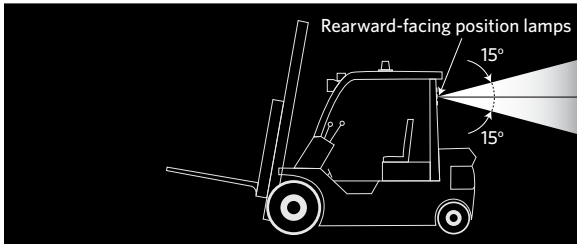

(a) Vertical beam angles

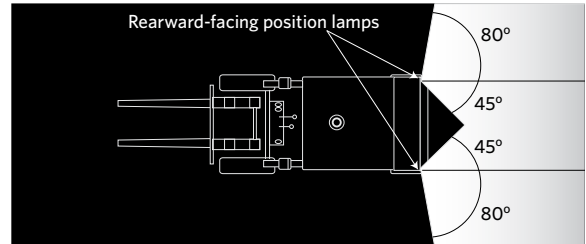

(b) Horizontal beam angles

Figure 4-7-1. Rearward-facing position lamp beam angles

Lighting 4-8 Side-marker lamps

Summary of legislation

Applicable legislation

- Land Transport Rule: Vehicle Lighting 2004

Permitted and prohibited equipment

1. A forklift with a length of 6 m or more may be fitted with one or more side-marker lamps.
2. A forklift with a length of less than 6 m must not be fitted with side-marker lamps.

Condition

3. A lamp must be in good condition.

Performance

4. A side-marker lamp must be operated in a way that is appropriate for the lamp and the vehicle.
5. A side-marker lamp must emit light that is:
 - a) diffuse, and
 - b) substantially red or amber to the rear, and
 - c) substantially white or amber to the front, and
 - d) steady.
6. Where a side-marker lamp comprises an array of light sources (eg LEDs), at least 75% of these must operate.

Reasons for rejection

Prohibited equipment

1. A forklift that has a length of less than 6 m is fitted with side-marker lamps.

Condition

2. A lamp is insecure or contains visible moisture or dirt.
3. A lens is missing, or has a hole, crack or other damage that allows moisture or dirt to enter.
4. A reflector is damaged or has deteriorated so that light output is reduced.

Performance

5. When switched on, a lamp emits a light that is not:
 - a) diffuse, or
 - b) substantially red or amber to the rear, or
 - c) substantially white or amber to the front, or
 - d) steady.
6. Where a lamp comprises an array of light sources (eg LEDs), fewer than 75% of these operate.

Note 1 Definitions

Side-marker lamp means a position lamp designed to be fitted to the side of a vehicle or its load.

Position lamp means a low-intensity lamp that is designed to indicate to road users the presence and dimensions of a vehicle being:

- a) a forward-facing position lamp (front side lamp), or
- b) a rearward-facing position lamp (rear side lamp or tail lamp), or
- c) a side-marker lamp, or
- d) an end-outline marker lamp (including cab roof lamp).

Note 2 A side-marker lamp that does not comply with the equipment, condition and performance requirements must be made to comply or be disabled so that it does not emit a light.

Lighting 4-9 End-outline marker lamps

Summary of legislation

Applicable legislation

- Land Transport Rule: Vehicle Lighting 2004

Mandatory, permitted and prohibited equipment

1. A vehicle in **Table 4-9-1** must or may be fitted with end-outline marker lamps as specified in the table.
2. A vehicle not listed in **Table 4-9-1** must not be fitted with end-outline marker lamps.
3. The position of the lamps must be such that it gives an indication of the vehicle's dimensions.

Condition

4. A end-outline marker lamp must be:
 - a) in good condition, and
 - b) not obscured (if a mandatory lamp).

Performance

5. An end-outline marker lamp must operate in a way that is appropriate for the lamp and the vehicle.
6. Cab roof lamps must emit a light that is visible from 100 m in normal daylight and from 200 in normal darkness.
7. A lamp must emit a light that is diffuse and substantially red to the rear and white or amber to the front.
8. A lamp must provide sufficient light output so that the vehicle's dimensions are easily indicated to other road users.
9. Where an end-outline marker lamp comprises an array of light sources (eg LEDs), at least 75% of these must operate.

Reasons for rejection

Mandatory, permitted and prohibited equipment

1. A vehicle listed in **Table 4-9-1**:
 - a) is not fitted with lamps required in **Table 4-9-1**, or
 - b) is fitted with lamps that exceed the numbers permitted in **Table 4-9-1**.
2. A vehicle not listed in **Table 4-9-1** is fitted with end-outline marker lamps.
3. An end-outline marker lamp is so positioned that it does not indicate the dimensions of the vehicle.

Condition

4. A lamp is insecure or contains visible moisture or dirt.
5. A lens is missing or has a hole, crack or other damage that allows moisture or dirt to enter.
6. A reflector is damaged or has deteriorated so that light output is reduced.
7. A mandatory lamp is obscured.

Performance

8. When switched on, a mandatory lamp does not operate.
9. When switched on, a lamp emits a light that is not:
 - a) substantially red to the rear, or
 - b) substantially white or amber to the front, or
 - c) diffuse, or
 - d) steady, or
 - e) bright enough to be visible from 100 m in normal daylight and 200m in normal darkness, eg due to modification, deterioration or an incorrect light source.
9. Where a lamp comprises an array of light sources (eg LEDs), fewer than 75% of these operate.

Lighting 4-9 End-outline marker lamps (cont.)

Table 4-9-1. Fitting requirements for end-outline marker lamps

	Vehicle type	Vehicle manufactured before 1/4/2011	Vehicle manufactured from 1/4/2011
A	<ul style="list-style-type: none"> A vehicle with a GVM exceeding 11,300 kg A vehicle with a towing connection and a total length exceeding 9.2 m.. 	<ul style="list-style-type: none"> must be fitted with two forward-facing end-outline marker lamps on the cab roof, and may be fitted with a total of 12 forward-facing end-outline marker lamps (including the cab roof lamps), and may be fitted with a total of six rearward-facing end-outline marker lamps. 	Not applicable.
B	<ul style="list-style-type: none"> A vehicle with a GVM exceeding 12,000 kg that exceeds 2.1 m in overall width A vehicle fitted with a towing connection that has a GCM exceeding 12,000 kg and where the vehicle exceeds 2.1 m in overall width. 	<ul style="list-style-type: none"> must be fitted with two forward-facing and two rearward-facing end-outline marker lamps that indicate the height of the vehicle may be fitted with a maximum of 12 forward-facing and six rearward-facing end-outline marker lamps. 	
C	A vehicle with a GVM of 12,000 kg or less that exceeds 2.1 m in overall width (other than a vehicle in A or B above).	<ul style="list-style-type: none"> must be fitted with two forward-facing and two rearward-facing end-outline marker lamps that indicate the height of the vehicle may be fitted with a maximum of six forward-facing and four rearward-facing end-outline marker lamps. 	
D	A vehicle that exceeds 1.8 m in overall width (other than one in A , B or C above).	<ul style="list-style-type: none"> may be fitted with a maximum of six forward-facing and four rearward-facing end-outline marker lamps. 	

Note **A** vehicle manufactured before 1/4/2011 has the option of complying with either the requirements listed under **A** or with the requirements listed in **B**, **C** or **D** as appropriate

Note 1 Definitions

End-outline marker lamp means a position lamp designed to be fitted near the outer extremity of a vehicle in addition to forward-facing and rearward-facing position lamps, and includes a cab roof lamp.

Position lamp means a low-intensity lamp that is designed to indicate to road users the presence and dimensions of a vehicle, being:

- a forward-facing position lamp (front side lamp), or
- a rearward-facing position lamp (rear side lamp or tail lamp), or
- a side-marker lamp, or
- an end-outline marker lamp (including cab roof lamp).

Note 23 **A** permitted end-outline marker lamp that does not comply with equipment, condition and performance requirements must be made to comply or be disabled so that it does not emit a light.

Lighting 4-10 Stop lamps

Summary of legislation

Applicable legislation

- Land Transport Rule: Vehicle Lighting 2004

Permitted equipment

1. A forklift may be fitted with one or two pairs of stop lamps at the rear which emit a light that is visible from 100 m.
2. A retrofitted pair of stop lamps must be symmetrically mounted as far towards each side of the vehicle as is practicable.
3. A retrofitted stop lamp must be fitted at a height from the ground not exceeding 2.1 m.
4. A forklift may be fitted at the rear with an additional pair of stop lamps provided they are positioned as close as is practicable to the top of the bodywork of the vehicle (top-mounted stop lamps).

Condition

5. A stop lamp must be in sound condition.

Performance

6. A stop lamp must operate in a way that is appropriate for the lamp and the vehicle.
7. The light emitted from a stop lamp must be diffuse light that is substantially red.
8. A stop lamp must operate when a service brake is activated.
9. A stop lamp must emit a steady light.
10. If a vehicle of American origin is fitted with combined stop and direction indicator lamps, the indicator lamps may override the stop lamps so that the stop lamps will operate as direction indicators.
11. Where a stop lamp comprises an array of light sources (eg LEDs), at least 75% of these must operate.

Reasons for rejection

Permitted equipment

1. A forklift is:
 - a) fitted with more than three pairs of stop lamps, or
 - b) fitted with a stop lamp that is not in a pair.
2. A retrofitted stop lamp, other than a top-mounted lamp, is fitted at a height from the ground exceeding 2.1 m.
3. A retrofitted pair of lamps is not:
 - a) symmetrically mounted, or
 - b) mounted as far towards each side of the vehicle as is practicable.
4. A pair of top-mounted stop lamps is not mounted as far as is practicable to the top of the bodywork of the vehicle.

Condition

5. A lamp is insecure or contains visible moisture or dirt.
6. A lens is missing, or has a hole, crack or other damage that allows moisture or dirt to enter.
7. A reflector is damaged or has deteriorated so that light output is reduced.

Performance

8. A lamp operates when the service brake is not applied.
9. A lamp emits a light that is not:
 - a) substantially red, or
 - b) diffuse, or
 - c) steady, or
 - d) projected to the rear, or
 - e) approximately equal in colour or intensity to the other lamp in a pair, or
 - f) bright enough to produce a light that is visible from 100 m in normal daylight, eg due to modification, deterioration or an incorrect light source.
10. Where a lamp comprises an array of light sources (eg LEDs), fewer than 75% of these operate.

Lighting

4-10 Stop lamps (cont.)

Reasons for rejection

12. On a vehicle of American origin fitted with combined stop and direction indicator lamps, the stop lamp function is not overridden by the indicator function.

Note 1 Stop lamp means a lamp that is designed to operate when the service brake is activated.

Note 2 A permitted stop lamp that does not comply with equipment, condition and performance requirements must be made to comply or be disabled so that it does not emit a light.

Note 3 An original equipment (OE) lamp is one that is fitted by the vehicle manufacturer in the original position, or is an equivalent replacement or aftermarket lamp suitable for the position provided by the vehicle manufacturer for that lamp. All other lamps are considered retrofitted (ie non-OE).

Note 4 A vehicle originally manufactured with a stop-lamp arrangement that differs from what is required or permitted in this section may retain the original stop lamps provided they remain fitted in their original position and perform as intended by the vehicle manufacturer.

Lighting

4-11 High-mounted stop lamps

Summary of legislation

Applicable legislation

- Land Transport Rule: Vehicle Lighting 2004

Permitted equipment

1. A forklift may be fitted with one or two high-mounted stop lamps.
2. A lamp must be fitted in a central high-mounted position at the rear of the vehicle.

Condition

3. A high-mounted stop lamp must be in good condition.

Performance

4. A high-mounted stop lamp must operate in a way that is appropriate for the lamp and the vehicle.
5. The light emitted from a high-mounted stop lamp must be diffuse light that is substantially red.
6. A high-mounted stop lamp must emit a steady light.
7. Where a high-mounted stop lamp comprises an array of light sources (eg LEDs), at least 75% of these must operate.

Reasons for rejection

Permitted equipment

1. A forklift is fitted with more than two high-mounted stop lamps.
2. A lamp is not fitted in a central high-mounted position.

Condition

3. A lamp is insecure, or contains visible moisture or dirt.
4. A lens is missing, or has a hole, crack or other damage that allows moisture or dirt to enter.
5. A reflector is damaged or has deteriorated so that light output is reduced.

Performance

6. When the service brake is activated a lamp does not remain steadily illuminated.
7. A lamp operates when the service brake is not activated.
8. A lamp emits a light that is not:
 - a) substantially red, or
 - b) diffuse, or
 - c) projected to the rear, or
 - d) bright enough to be visible from 100 m in normal daylight, eg due to modification, deterioration or an incorrect light source.
9. Where a lamp comprises an array of light sources (eg LEDs), fewer than 75% of these operate.

Note 1 Definitions

High-mounted stop lamp means a stop lamp that is designed to be fitted in a central, high-mounted position at the rear of a vehicle.

Stop lamp means a lamp that is designed to operate when the service brake is activated.

Note 2 A high-mounted stop lamp that does not comply with equipment, condition and performance requirements must be made to comply or be disabled so that it does not emit a light.

Note 3 A vehicle originally manufactured with a high-mounted-stop-lamp arrangement that differs from what is required or permitted in this section may retain the original high-mounted stop lamps provided they remain fitted in their original position and perform as intended by the vehicle manufacturer.

Lighting

4-12 Rear-registration-plate illumination lamps

Summary of legislation

Applicable legislation

- Land Transport Rule: Vehicle Lighting 2004

Permitted equipment

1. A forklift may be fitted with one or more rear-registration-plate illumination lamps.

Performance

2. A rear-registration-plate illumination lamp must operate in a way that is appropriate for the lamp and the vehicle.
3. A lamp must emit a diffuse light that is substantially white.
4. A rear-registration-plate illumination lamp must emit a steady light.
5. The light source of the lamp must not be visible from the rear of the vehicle.
6. A lamp must illuminate the figures and letters of the plate so that they are visible from 20 m during normal darkness.
7. Where a lamp comprises an array of light sources (eg LEDs), at least 75% of these must operate.

Reasons for rejection

Performance

1. The lamp emits a light that is not:
 - a) substantially white, or
 - b) steady, or
 - c) diffuse.
2. The lamps are not bright enough to show up the registration plate text from 20 m in normal darkness.
3. The light source of a lamp is visible from the rear of the vehicle.

Note 1 Rear-registration-plate illumination lamp means a lamp designed to illuminate the rear registration plate of a vehicle.

Note 2 A vehicle originally manufactured with a rear-registration-plate-illumination-lamp arrangement that differs from what is required or permitted in this section may retain the original rear-registration-plate illumination lamps provided they remain fitted in their original position and perform as intended by the vehicle manufacturer.

Lighting 4-13 Rear reflectors

Summary of legislation

Applicable legislation

- Land Transport Rule: Vehicle Lighting 2004

Mandatory and permitted equipment

- A forklift must be fitted with one or more pairs of rearward-facing reflectors at a height from the ground not exceeding 1.5 m, or if this is not practicable due to the shape of the bodywork of the vehicle, not exceeding 2.1 m.
- A rearward-facing reflector must be positioned to the rear of the vehicle.
- A reflector must be of an area that allows it to reflect light to improve the visibility of the vehicle to other road users, but it must not cause them undue dazzle or discomfort.
- A retrofitted pair of reflectors must be symmetrically mounted as far towards each side of the vehicle as is practicable.

Condition

- A reflector must be in good condition and not be obscured.

Performance

- A reflector must operate in a way that is appropriate for the reflector and the vehicle.
- A reflector must reflect white light as substantially red light.
- A reflector must provide sufficient light reflection to fulfil its intended purpose.

Reasons for rejection

Mandatory and permitted equipment

- A forklift:
 - is not fitted with at least one rearward-facing reflector on each side, or
 - is fitted with a rearward-facing reflector that is not in a pair.
- A retrofitted reflector is fitted at a height from the ground exceeding 1.5 m (or 2.1 m where fitting below 1.5 m is not practicable due to the shape of the bodywork of the vehicle).
- A reflector is not positioned to the rear of the vehicle.
- A retrofitted pair of reflectors is not:
 - symmetrically mounted, or
 - mounted as far towards each side of the vehicle as is practicable.

Condition

- A mandatory reflector's ability to reflect light is affected by excessive:
 - fading, or
 - scratching or other damage.
- A mandatory reflector is obscured.

Performance

- The reflected light from a mandatory reflector is not visible from 100 m.
- The reflected light from a reflector is not red.

Note 1 Definitions

Reflector means a discreet item of lighting equipment that is designed to reflect incident light back towards the light source, but does not include reflective material (such as reflective tape).

Reflective material means any material that is designed to reflect incident light back towards the light source, and includes reflective tape, but does not include a reflector.

Note 2 A vehicle originally manufactured with a rear reflector arrangement that differs from what is required or permitted in this section may retain the original rear reflectors provided they remain fitted in their original position and perform as intended by the vehicle manufacturer.

Lighting 4-14 Reversing lamps

Summary of legislation

Applicable legislation

- Land Transport Rule: Vehicle Lighting 2004

Permitted equipment

1. A forklift may be fitted with one or two reversing lamps fitted at the rear of the vehicle.
2. A retrofitted pair of reversing lamps must be symmetrically mounted as far towards each side of the vehicle as is practicable.

Condition

3. A reversing lamp must be in good condition.

Performance

4. A reversing lamp must operate in a way that is appropriate for the lamp and the vehicle.
5. A reversing lamp, when operated, must emit a diffuse light or a dipped beam of light that is substantially white (**Note 3**).
6. A reversing lamp must emit a steady light.
7. A reversing lamp may operate only when the reverse gear is engaged or the headlamps are turned off.
8. Where a reversing lamp comprises an array of light sources (eg LEDs), at least 75% of these must operate.

Reasons for rejection

Permitted equipment

1. A forklift is fitted with more than two reversing lamps at the rear of the vehicle.
2. A retrofitted pair of reversing lamps is not:
 - a) symmetrically mounted, or
 - b) mounted as far towards each side of the vehicle as is practicable.

Condition

3. A lamp is insecure or contains visible moisture or dirt.
4. A lens is missing, or has a hole, crack or other damage that allows moisture or dirt to enter.
5. A reflector is damaged or has deteriorated so that light output is reduced.

Performance

6. A lamp controlled by gear engagement continues to display a light to the rear when the reverse gear is disengaged.
7. A lamp controlled by a manual switch continues to display a light to the rear while the headlamps are switched on.
8. When engaged, a lamp emits light that is not:
 - a) substantially white (**Note 3**), or
 - b) steady, or
 - c) diffuse or a dipped beam.
9. Where a lamp comprises an array of light sources (eg LEDs), fewer than 75% of these operate.

Note 1 **Reversing lamp** means a lamp designed to illuminate the area behind the vehicle while it is reversing and to warn other road users that the vehicle is reversing or about to reverse.

Note 2 A reversing lamp that does not comply with equipment, condition and performance requirements must be made to comply or be disabled so that it does not emit a light.

Note 3 Vehicles first registered in New Zealand before 27 February 2005 were allowed to use rear indicator lamps as reversing lamps. Although the light emitted is amber instead of white, this arrangement is still permitted for these vehicles.

Note 4 A vehicle originally manufactured with a reversing lamp arrangement that differs from what is required or permitted in this section may retain the original reversing lamps provided they remain fitted in their original position and perform as intended by the vehicle manufacturer.

Lighting 4-15 Cosmetic lamps

Summary of legislation

Applicable legislation

- Land Transport Rule: Vehicle Lighting 2004

Permitted equipment

1. A vehicle may be fitted with one or more lamps not specified in **Table 4-15-1**, provided they are fitted so that light sources are not visible in those regions specified in **Figure 4-15-1**.
2. A lamp must be fitted in a fixed position on the vehicle and positioned so that no part of the light source is situated within 250 mm of a mandatory lamp.

Performance

3. A lamp must:
 - a) only emit light that is diffuse, and
 - b) not emit light that flashes or otherwise varies in intensity or colour, and
 - c) be fitted in a way, and be of a luminance that ensures, that it does not dazzle, confuse or distract other road users, and
 - d) not emit a light that revolves, rotates or otherwise moves, and
 - e) not cause confusion as to the orientation of the vehicle, and
 - f) not emit a red light that is directly visible from the front of the vehicle, and
 - g) not emit a light other than red or amber if the light is directly visible from the rear of the vehicle.

Reasons for rejection

Permitted equipment

1. A cosmetic lamp (ie one not listed in **Table 4-15-1**) that is fitted to a vehicle:
 - a) has a part of its light-emitting surface positioned within 250 mm of any mandatory lamps, or
 - b) is not mounted in a fixed position, or
 - c) is positioned so that its light-emitting surface is visible within the shaded areas in **Figure 4-15-1**.

Performance

2. When switched on, a cosmetic lamp with a light-emitting surface not visible within the shaded areas in **Figure 4-15-1** emits a light that:
 - a) is not diffuse, or
 - b) flashes or otherwise varies in intensity or colour, or
 - c) revolves, rotates or otherwise moves, or
 - d) is too bright and likely to dazzle other road users, or
 - e) is likely to cause confusion about the orientation of the vehicle, or
 - f) is red when seen directly from the front, or
 - g) is not red or amber when seen directly from the rear.

Lighting 4-15 Cosmetic lamps (cont.)

Table 4-15-1. Lamps that are not cosmetic lamps

Lamps covered in the VIRM	Other lighting equipment not requiring inspection
Headlamps	Reflective material
Stop lamps	Interior lamps <i>Designed to illuminate the interior of the vehicle for the convenience of passengers</i>
High-mounted stop lamps	Work lamps <i>White or amber high-intensity lamps that are not necessary for the operation of the vehicle but are designed to illuminate the area around the vehicle or the vehicle itself</i>
Direction indicator lamps	Scene lamps <i>Work lamps designed to provide a fixed or movable beam of light to illuminate the area around the vehicle or the vehicle itself</i>
Position lamps (includes side-marker lamps and end-outline marker lamps)	Alley lamps <i>Work lamps designed primarily to provide a fixed or movable beam of light to the side of the vehicle it is fitted to</i>
Rear-registration-plate illumination lamps	Flashing or revolving beacons (except a mandatory beacon required for some overdimension vehicles)
Rear reflectors	Illuminated vehicle-mounted signs <i>Includes PSV destination signs, taxi signs, and variable message signs operated by enforcement officers, under a traffic management plan or permitted by other legislation</i>
Fog lamps	
Daytime running lamps	
Cornering lamps	
Reversing lamps	
PSV interior lamps	

Note 1 A rear or side cosmetic lamp that does not comply with requirements for condition or performance must be made to comply, or be disabled so that it does not emit a light.

Note 2 Definitions

Lamp means a device designed to emit light, and includes an array of separate light sources that appear as a continuous illuminated surface.

Cosmetic lamp means any lamp that is not listed in **Table 4-15-1**.

Note 3 A forward-facing cosmetic lamp that does not comply with the equipment, condition and performance requirements must be made to comply or be removed from the vehicle.

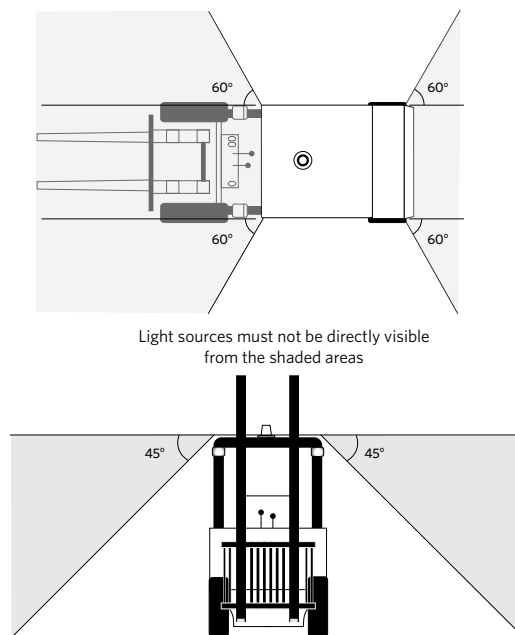

Figure 4-15-1. Visibility angles for cosmetic lamps

Vision 5-1 Glazing

Summary of legislation

Applicable legislation

- Land Transport Rule: Glazing, Windscreen Wipe and Wash, and Mirrors 1999

Glazing condition

- Glazing must be mechanically sound, strong and securely affixed to the vehicle.
- A windscreen and front side windows must be clean and free of obstruction to ensure the driver has sufficient vision through the glazing to operate the vehicle safely.
- A windscreen must not have scratches and other defects that:
 - unreasonably impair vision, or
 - compromise its strength.
- A laminated windscreen must not show signs of discoloration that could unreasonably impair the driver's vision.
- Glazing in roof panels may be tinted.

Glazing performance

- A windscreen must have an overall visible light transmittance (VLT) of at least 70%.
- A front side window must have an overall VLT of at least 35%.
- Glazing must not have a mirrored effect sufficient to dazzle other road users.
- A modification must not:
 - unreasonably impair vision through a windscreen or a front side window, or
 - adversely affect the strength or mechanical performance of the glazing or the vehicle.

Permitted modifications

- A modification that affects glazing is permitted if within the limits in **Table 5-1-1**.

Reasons for rejection

Glazing condition

- A piece of glazing is not mechanically sound, or is not securely affixed to the vehicle.
- A windscreen or front side window is so dirty or obstructed that the driver's vision is unreasonably impaired.
- A windscreen has damage that prevents the wiper blades from working properly.
- A windscreen has scratches, discolouration or other defects that unreasonably impair the driver's vision or compromise the strength of the windscreen.
- A modification:
 - unreasonably impairs driver's vision through the windscreen or a front side window, or
 - adversely affects the strength or mechanical performance of the glazing.

Glazing performance

- The overall visible light transmittance (VLT) (**Note 4**) of a windscreen is less than 70%.
- The overall VLT of a front side window is less than 35%.
- Glazing has a mirrored effect sufficient to dazzle other road users.

Permitted modifications

- A modification that affects glazing is not within the limits in **Table 5-1-1**.

Vision 5-1 Glazing (cont.)

Table 5-1-1. Permitted modifications

Fitting of or modification to:	Modification permitted provided that:
Windscreens	
Stickers	<ul style="list-style-type: none"> ▪ stickers are wholly within 100 mm of the top or bottom edge, or 50 mm of the side edges, unless required or permitted by legislation, eg: <ul style="list-style-type: none"> - a licence label - a road user licence label - a WoF label - an alternative fuel sticker - a current parking permit or other document issued by the local authority - learner L-plates (in sticker format) provided the driver's vision is not unreasonably affected.
Anti-glare band overlay	<ul style="list-style-type: none"> ▪ the overlay is transparent, and ▪ the overlay does not extend below the bottom edge of the vehicle's OE sun visors when they are folded down as far as possible towards the windscreen, and ▪ the overlay does not contain print below a line that is 100 mm below and parallel to the top edge of the windscreen.
Radio antennae	<ul style="list-style-type: none"> ▪ antennae are wholly within 100 mm of any edge.
Front side windows	
Transparent overlays	<ul style="list-style-type: none"> ▪ the overall visible light transmittance (VLT) is not reduced to below 35%.
Stickers	<ul style="list-style-type: none"> ▪ stickers are wholly within 100 mm of the bottom edge, or 50 mm of any other edge, unless required or permitted by legislation. ▪ manufacturer's operating instructions may be applied to or incorporated in the glazing.
Radio antennae	<ul style="list-style-type: none"> ▪ antennae are wholly within 100 mm of any edge.
Rear and rear side windows (behind the driver's seat)	
Overlays and other modifications	<ul style="list-style-type: none"> ▪ the vehicle is equipped on both sides with external rear-view mirrors.
Stickers	<ul style="list-style-type: none"> ▪ stickers may be applied anywhere on the glazing, but if not wholly within 100 mm of any edge, the vehicle must be equipped on both sides with external rear-view mirrors.
Radio antennae	<ul style="list-style-type: none"> ▪ in-service requirements for condition and performance are met.
Fitting of or modification to:	Modification always permitted:
Monsoon shields	<ul style="list-style-type: none"> ▪ in-service requirements for condition and performance must be met.
Electric demisters	
Sunroofs (overlays and stickers applied anywhere on the glazing, radio antennae, and electric demisters)	

Definitions

Windscreen means all glazing extending across the front of the vehicle that is not parallel to the vehicle's centreline but does not include a wind deflector. No fitting or overlays of stickers are permitted to the windscreen except those previously mentioned.

Overlay means a transparent, translucent or opaque self-adhesive or clinging film that is applied to large areas, or the whole, of a piece of glazing, including anti-glare band overlays and stoneguard overlays.



Sticker means a self-adhesive or clinging film, with or without print on it, that is applied for purposes such as advertising, identification, information, decoration or legal reasons.

Anti-glare band overlay means a tinted overlay that is transparent and that is applied along the top edge of the windscreen for the purpose of reducing glare from the sun.

Damage includes any unrepaired damage and attempted visible repairs.

Visible light transmittance (VLT) is the proportion of visible light that passes through glazing, measured perpendicular to the glazing. Overall VLT is the VLT of the glazing together with any overlays.

Any OE opaque edging (usually black) is not considered part of the windscreen when determining the boundaries permitted for stickers, print on an anti-glare band or radio antennae.

Vision**5-2 Sun visors****Summary of legislation****Applicable legislation**

- Land Transport Rule: Vehicle Equipment 2004
- Land Transport Rule: Interior Impact 2002

Permitted equipment

1. A forklift may be fitted with sun visors (**Note 1**).

Performance

2. The condition of sun visors must be such that the likelihood of injury to occupants is minimised.
3. A driver's sun visor must be effective.

Reasons for rejection**Condition**

1. A sun visor (**Note 1**):
 - a) is insecurely mounted, or
 - b) for the driver, cannot be adjusted from the normal driving position, or
 - c) cannot maintain its adjusted position, or
 - d) has been modified or has deteriorated, and the likelihood of injury to vehicle occupants has not been minimised.

Performance

2. A driver's sun visor does not effectively aid the driver's vision by intercepting the glare from the sun.

Note 1 Sun visor means any attachment mounted above the inside of the windscreen and provided for the purpose of shielding the eyes of the driver and other front seat passengers from solar glare.

Vision 5-3 Windscreen wipe and wash

Summary of legislation

Applicable legislation

- Land Transport Rule: Glazing, Windscreen Wipe and Wash, and Mirrors 1999

Mandatory equipment

- A forklift that is fitted with a windscreen must have a windscreen wipe system.
- Windscreen wipers must be power driven, unless they follow OE specifications in a vehicle manufactured before 1 January 1960.

Permitted equipment

- A forklift may be fitted with a wash system.

Condition

- A forklift's windscreen wipe and wash system must be efficient and within the vehicle manufacturer's operating limits.

Performance

- The equipment fitted must be capable of keeping an adequate area of the windscreen clean and clear so that the vehicle may be operated safely under all reasonably foreseeable conditions.

Reasons for rejection

Mandatory equipment

- A forklift that has a windscreen is not fitted with a windscreen wipe system.
- A forklift manufactured on or after 1 January 1960 is fitted with wipers that are not power driven.

Condition

Windscreen wipe system

- The wiper operating device is missing.
- A wiper arm or wiper blade is:
 - missing, or
 - insecure, or
 - damaged so as to affect the performance of the wipers.
- The wiper operating mechanism is:
 - missing, or
 - insecure, or
 - damaged so as to affect the performance of the wipers.

Windscreen wash system

- A wash system component is missing or insecure.
- The wash operating device is missing.

Performance

Windscreen wipe system

- A windscreen wiper does not wipe the windscreen effectively, preventing adequate forward vision by the driver.
- The wipe operating device is unable to activate the wipe system.

Windscreen wash system

- A windscreen wash nozzle does not discharge washer liquid directly onto the windscreen.
- The wash operating device is unable to activate the wash system.

Vision 5-4 Rear-view mirrors

Summary of legislation

Applicable legislation

- Land Transport Rule: Glazing, Windscreen Wipe and Wash, and Mirrors 1999

Mandatory equipment

1. A forklift must be fitted with a rear-view mirror.

Permitted equipment

2. Additional rear-view mirrors may be fitted.

Condition

3. A rear-view mirror must be:
 - a) securely attached so that the risk of injury is minimised, and
 - b) mounted so that vibration does not inhibit the driver's required clear view to the rear, and
 - c) sufficiently adjustable, and able to maintain its position.

Performance

4. A rear-view mirror must provide a clear view to the rear of:
 - a) the forklift itself, and
 - b) the forklift's load, and
 - c) any towed trailer and its load.
5. A rear-view mirror must be sufficiently isolated from vibrations.

Reasons for rejection

Mandatory equipment

1. A forklift is not fitted with at least one rear-view mirror.

Condition

2. A rear-view mirror:
 - a) is not mounted securely, or
 - b) cannot be adjusted, or
 - c) cannot maintain its adjusted position, or
 - d) is corroded or dirty, or
 - e) is damaged so that it increases the risk of injury to vehicle occupants.

Performance

3. A rear-view mirror:
 - a) does not provide a clear view to the rear of the vehicle, or
 - b) is not sufficiently isolated from vibrations.

Entrance and exit

6-1 Door and hinged panel retention systems

Summary of legislation

Applicable legislation

- Land Transport Rule: Door Retention Systems 2001
- Land Transport Rule: Vehicle Standards Compliance 2002, section 7.4

Mandatory equipment

1. A forklift fitted with doors used by the driver or passengers for entrance and exit of the vehicle must have a door retention system.

Condition

2. A door retention system and its mountings must be safe and structurally sound.
3. A door used for the entrance and exit of the driver or passengers must be operable by any occupant seated by the door from inside the vehicle.
4. The forklift must be designed and constructed using components and materials that are fit for their purpose, and within safe tolerance of their state when manufactured or modified.

Performance

5. A door retention system must be in good working order.
6. A door used for entrance and exit must open and close easily.
7. A door used for entrance and exit must remain secure in a closed position during the operation of the vehicle.

Reasons for rejection

Mandatory equipment

1. A forklift fitted with doors used by the driver or passengers for entrance and exit of the vehicle does not have a door retention system.

Condition

2. A hinge for a door or other hinged panel is not securely attached to both the vehicle body and to the door or other hinged panel, eg due to loose connections, corrosion or other damage.
3. A door used for entrance and exit of the driver or passengers cannot be opened from the inside.

Performance

4. A door used for entrance and exit of the driver or passengers does not open or close easily, eg a door is sticking or requires unreasonable force to open.
5. A door or other hinged panel does not remain secure in a closed or locked position.

Note 1 Corrosion damage is where the metal has been eaten away, which is evident by pitting. The outward sign of such corrosion damage is typically displayed by the lifting or bubbling of paint. In extreme cases, the area affected by the corrosion damage will fall out and leave a hole.

Vehicle interior

7-1 Seats and seat anchorages

Summary of legislation

Applicable legislation

- Land Transport Rule: Seats and Seat Anchorages 2002

Mandatory equipment

1. A driver's seat in a forklift must remain fitted.
2. A seat in a forklift must be fitted to the vehicle structure by means of seat anchorages.

Condition and performance

3. Seats and seat anchorages must be safe, strong, in sound condition and compatible in strength with each other and with the vehicle structure.
4. The driver's seat and its anchorages must be designed, constructed and maintained to enable the driver to have proper control of the vehicle.
5. Seats and seat anchorages must be securely attached to the vehicle structure.
6. When a seatbelt or any part of the seatbelt is integral to a seat, the seat and seat anchorages must be compatible in strength with the seatbelt or with that part of the seatbelt attached to the seat.

Reasons for rejection

Mandatory equipment

1. A driver's seat is not fitted in a forklift that was originally fitted with a driver's seat.
2. A seat is not attached to the vehicle structure by seat anchorages.

Condition and performance

3. A seat frame or structure has been weakened, eg due to damage, corrosion or excessive wear.
4. The adjustment mechanism of a driver's seat:
 - a) does not operate, or
 - b) is worn ,causing excessive movement of the seat.
5. The attachment of the seat to the seat anchorage is loose or weakened by damage.
6. The attachment of the seat anchorage to the vehicle structure is loose or weakened by damage.
7. The driver's seat is in such a condition that it does not allow the driver to have proper control of the vehicle.

Note 1 A seat may be capable of being rotated or placed to face in different directions.

Note 2 Corrosion damage is where the metal has been eaten away, which is evident by pitting. The outward sign of such corrosion damage is typically displayed by the lifting or bubbling of paint. In extreme cases, the area affected by the corrosion damage will fall out and leave a hole.

Vehicle interior**7-3 Head restraints****Summary of legislation****Applicable legislation**

- Land Transport Rule: Head Restraints 2001

Permitted equipment

1. A forklift may be fitted with head restraints.

Condition and performance

2. The external surfaces and padding of a head restraint must not have deteriorated to the extent that the likelihood of injury to an occupant of the vehicle is increased.
3. An adjustable head restraint must remain able to be adjusted and locked into position.

Reasons for rejection**Condition and performance**

1. The external surfaces and padding of a head restraint have deteriorated to the extent that they are likely to injure a vehicle occupant.
2. An adjustable head restraint is unable to remain locked in its adjusted position.

Vehicle interior

7-7 Interior impact

Summary of legislation

Applicable legislation

- Land Transport Rule: Interior Impact 2001

Condition and performance

1. Interior fittings, controls and surfaces in the passenger compartments must be such that the likelihood of injury to occupants is minimised.

Reasons for rejection

Condition and performance

1. Where an interior fitting, control or surface has been modified or has deteriorated, the likelihood of injury to occupants has not been minimised.

Vehicle interior 7-12 Speedometer

Summary of legislation

Applicable legislation

- Land Transport Rule: Vehicle Equipment 2004

Mandatory equipment

1. A forklift first registered in New Zealand on or after 1 December 1951 that is capable of a speed exceeding 50 km/h must be fitted with a speedometer (**Note 1**).
2. A vehicle is not required to have a speedometer if the speedometer or associated equipment:
 - a) has been removed for repair and there are no undue delays by the vehicle owner in having it replaced, or
 - b) is out of repair, repair is impracticable and a suitable replacement is not available.

Performance

3. The speedometer must be in good working order and operate while the vehicle is moving forward.

Reasons for rejection

Mandatory equipment

1. A forklift first registered in New Zealand on or after 1 December 1951 that is capable of a speed exceeding 50 km/h is not fitted with a speedometer, and the vehicle operator cannot produce acceptable written evidence (**Note 2**) that:
 - a) the speedometer has been removed for repair, or
 - b) there are no undue delays by the vehicle owner in having the speedometer replaced.

Condition and performance

2. The speedometer:
 - a) does not operate as intended when the vehicle is moving forward, or
 - b) is obscured from the driver's vision, or
 - c) does not indicate the vehicle's speed in km/h or mph.
3. Reason for rejection 2(a), 2(b) or 2(c) applies and the vehicle operator cannot produce acceptable written evidence (**Note 2**) that repair of the speedometer or associated equipment is impracticable or that a suitable replacement is not available.

Note 1 **Speedometer** means an instrument in a motor vehicle that is used to determine forward speed of the vehicle in kilometres per hour (km/h) or miles per hour (mph).

Note 2 Acceptable written evidence is documentation provided by the speedometer repairer or supplier. A copy of the documentation must be kept on file with the checksheet.

Vehicle interior**7-13 Audible warning devices****Summary of legislation****Applicable legislation**

- Land Transport Rule: Vehicle Equipment 2004

Mandatory equipment

1. A forklift must be fitted with a device (horn) that is audible to other road users.

Permitted equipment

2. A forklift may be fitted with a bell, whistle or siren that is part of an anti-theft car alarm, personal security alarm or a reversing warning device.

Performance

3. The device must be in good working order.
4. The device must be capable of giving a warning that is audible under normal traffic conditions from a distance of at least 100 m.

Reasons for rejection**Mandatory equipment**

1. A forklift is:
 - a) not fitted with a horn, or
 - b) fitted with a bell or whistle that is not part of an anti-theft car alarm, personal security alarm or a reversing warning device.

Performance

2. The horn does not operate when activated.
3. The horn operates when not activated.
4. The sound from the horn is not steady and continuous, eg the horn plays a tune.
5. The horn is not audible at a distance of 100 m.

Brakes

8-1 Service brake and parking brake

Summary of legislation

Applicable legislation

- Land Transport Rule: Light-Vehicle Brakes 2002
- Land Transport Rule: Heavy-Vehicle Brakes 2006

Mandatory equipment

1. A forklift must have:
 - a) a service brake, and
 - b) a parking brake.

Permitted equipment

2. A forklift may be fitted with a warning system that is part of, or associated with, the use of a brake component or system.

Condition

3. A brake must be in good condition and within safe tolerance of its state when manufactured.
4. The brake friction surfaces must be within safe tolerance of their state when manufactured, and must not be scored, weakened or damaged to the extent that the safety performance of the brake is adversely affected.

Performance

5. The service brake must be able to be applied in a controlled and progressive manner.
6. When the brake is applied:
 - a) the vehicle or its controls must not vibrate to the extent that control of the vehicle is adversely affected, and
 - b) the braking effort on each wheel must provide stable and efficient braking without adverse effect on the directional control of the vehicle, and
 - c) if the vehicle is equipped with an anti-lock braking system (ABS), the wheels must not lock, other than when the speed of the vehicle falls below the ABS activation parameters set by the vehicle manufacturer.
7. A brake warning system must function correctly (does not apply to a brake pad wear warning system).

Service brake

8. The service brake of a forklift that is operated on a hard, dry, level surface that is free of loose material and without assistance from the compression of the engine or other retarders, must operate in the following manner:
 - a) the service brake must stop the unladen forklift (GVM 3500 kg or less) within a distance of 9 m from a speed of 30 km/h (average brake efficiency of 40%), or

Reasons for rejection

Mandatory equipment

1. A forklift does not have a service brake.
2. A forklift does not have a parking brake.

Condition

Service brake

3. There is corrosion damage (**Note 2**) within 150 mm of a brake component mounting point.
4. The **service brake pedal**:
 - a) is insecure, or
 - b) is spongy (indicating air in the system), or
 - c) creeps, or
 - d) has a non-slip surface which has deteriorated to such an extent that the brake cannot be safely applied, or
 - e) has excessive travel.
5. A **vacuum hose or pipe** (including connections) is:
 - a) insecure, or
 - b) leaking, or
 - c) damaged (cracked, chafed, twisted, stretched, or corroded, eg showing signs of pitting or a noticeable decrease in the pipe's outside diameter).
6. The **brake vacuum servo** (brake booster) is:
 - a) not functioning fully or adequately, or
 - b) leaking, or
 - c) insecure.
7. The **brake master cylinder** is:
 - a) leaking brake fluid, or
 - b) insecure, or
 - c) excessively corroded.
8. A **brake valve** is:
 - a) not operating (has eg a seized load sensing valve), or
 - b) leaking brake fluid, or
 - c) insecure, or
 - d) excessively corroded.

Brakes**8-1 Service brake and parking brake (cont.)**

- b) the service brake must stop the unladen forklift (GVM more than 3500 kg) within a distance of 7 m from a speed of 30 km/h (average brake efficiency of 50%), or
- c) the service brake must stop the unladen forklift (with a maximum speed of 20-29 km/h) within a distance of 4 m from a speed of 20 km/h (average brake efficiency of 40%), or
- d) the service brake must stop the unladen forklift (with a maximum speed of less than 20 km/h) within a distance of 4 m from its maximum speed.

Parking brake

- 9. A parking brake must hold the unladen forklift at rest on a slope of one in six.

Reasons for rejection

- 9. A brake pipe (including connections) is:
 - a) leaking brake fluid, or
 - b) insecure, or
 - c) deformed from its original shape, or
 - d) chafed, or
 - e) corrosion damaged, eg there are signs of pitting or a noticeable increase in the pipe's outside diameter.
- 10. A flexible hydraulic brake hose (including connections):
 - a) is leaking brake fluid, or
 - b) is insecure, or
 - c) bulges under pressure, or
 - d) is twisted, stretched or chafed, or
 - e) has an external sheathing which is cracked to the extent that the reinforcing cords are exposed, or
 - f) has metal connections which are excessively corroded, or
 - g) has an end fitting that is not attached to the hose by means of swaging, machine crimping or a similar process (**Note 3**).
- 11. A brake calliper:
 - a) shows visible signs of leaking, or
 - b) is insecure.
- 12. A brake backing plate is:
 - a) insecure, or
 - b) severely corroded, or
 - c) deformed from its original shape, or
 - d) cracked, or
 - e) contaminated by brake fluid, oil or grease.
- 13. A wheel cylinder:
 - a) shows visible signs of leaking, or
 - b) is insecure, or
 - c) is seized.

Reasons for rejection

14. An **ABS system component** is damaged, insecure or missing.
15. A **brake disc or drum** is:
 - a) worn beyond manufacturer's specifications (where visible without removing vehicle components), or
 - b) fractured or otherwise damaged (where visible without removing vehicle components), or
 - c) contaminated by brake fluid, oil or grease.
16. **Brake friction material** (where visible without removing vehicle components) is:
 - a) worn below manufacturer's specifications, or
 - b) separating from the brake pad backing plate or brake shoe, or
 - c) contaminated by brake fluid, oil or grease.
17. A **service brake component** shows signs of heating or welding after original manufacture.

Parking brake

18. The **parking brake lever**:
 - a) has excessive travel, or
 - b) is insecure, or
 - c) has mounting which is damaged, corroded, distorted or fractured within 150 mm of the lever mounting, or
 - d) mechanism or lever pivot bearing is worn or damaged so that the parking brake could be easily released by accident.
19. The **parking brake cable**:
 - a) is knotted, frayed or excessively corroded, or
 - b) has an auxiliary tensioner fitted, or
 - c) has otherwise deteriorated so that it may affect the parking brake performance.
20. A **parking brake actuating rod or guide**:
 - a) is excessively corroded, or
 - b) is excessively worn, or
 - c) has otherwise deteriorated so that it may affect the parking brake performance.

Brakes**8-1 Service brake and parking brake (cont.)****Reasons for rejection**

21. A parking brake component shows signs of heating or welding after original manufacture.

Performance**Service brake**

22. The service brake cannot be applied in a controlled and progressive manner.

23. When the service brake is applied without assistance from the engine:

- a) the unladen forklift (GVM 3500 kg or less) does not stop within 9 m from a speed of 30 km/h (average brake efficiency of 40%), or
- b) the unladen forklift (GVM more than 3500 kg) does not stop within 7 m from a speed of 30 km/h (average brake efficiency of 50%), or
- c) the unladen forklift (maximum speed 20–29 km/h) does not stop within 4 m from a speed of 20 km/h (average brake efficiency of 40%), or
- d) the unladen forklift (maximum speed less than 20 km/h) does not stop within 4 m from its maximum speed.

24. When the service brake is applied:

- a) the vehicle vibrates under braking to the extent that the control of the vehicle is adversely affected, or
- b) the brake fails to release immediately after the brake pedal has been released, or
- c) the directional control is affected (eg there is swerving to one side, or the brakes on one side apply more slowly than on the other side).

25. The brake system warning lamp or self-check system, if fitted, indicates a defect in the brake system (this does not apply to brake pad wear warning systems).

Parking brake

26. When the parking brake is applied it does not hold:

- a) the vehicle at rest on a slope of one in six (ie a 17% or 9° slope), or
- b) the wheels on a common axle stationary against attempts to drive the vehicle away.



Note 1 Definitions

Service brake means a brake for intermittent use that is normally used to slow down and stop a vehicle.

Parking brake means a brake readily applicable and capable of remaining applied for an indefinite period without further attention. A parking brake may be lever operated, or may be a transmission lock or a service brake that is capable of being locked in the applied position.

Note 2 Corrosion damage is where the metal has been eaten away, which is evident by pitting. The outward sign of such corrosion damage is typically displayed by the lifting or bubbling of paint. In extreme cases, the area affected by the corrosion damage will fall out and leave a hole.

Note 3 Hose end fittings that can be undone using hand tools are unacceptable.

Note 4 If a brake is fitted with an inspection port plug, this must be removed for inspection of the brake components.

Steering

9-1 Steering and suspension systems

Summary of legislation

Applicable legislation

- Land Transport Rule: Steering Systems 2001

Mandatory equipment

1. A forklift capable of a speed of more than 50 km/h and equipped with a modified or aftermarket steering system with no direct mechanical connection between the driver's means of control and the wheels, or other means of changing the vehicle's direction, must have at least one additional means of steering.

Condition

2. The steering system and associated systems and components that directly or indirectly affect the directional control of the vehicle must be:
 - a) sound and in good condition, and
 - b) strong, durable and fit for their purpose, taking into account whether adverse effects have resulted from a loss of integrity of any protective system used by a relevant component.

Performance

3. The steering system and associated systems and components that directly or indirectly affect the directional control of the vehicle must provide the vehicle with safe, efficient, convenient and sensitive control.

Reasons for rejection

Mandatory equipment

1. A forklift capable of exceeding a speed of 50 km/h equipped with a modified or aftermarket steering system with no direct mechanical connection between the driver's means of control and the wheels, or other means of changing the vehicle's direction, does not have at least one additional means of steering.

Condition

2. The **steering wheel**:
 - a) is insecurely attached to the steering shaft, or
 - b) shows excessive movement indicating unacceptable wear or looseness in the steering box or rack or steering column bearings, or
 - c) has a rim covering which is insecure so that the directional control of the vehicle is affected.
3. The **steering column** is insecure.
4. The **power steering**:
 - a) has been disconnected, or
 - b) system does not operate correctly, requiring unreasonable force to steer the vehicle, or
 - c) has a hose, pump drive, drive belt or pump mounting that is insecure, damaged, or has significantly deteriorated, or
 - d) has a significant fluid leak.
5. The **hydrostatic steering system**:
 - a) has been disconnected, or
 - b) does not operate correctly, eg requiring unreasonable force to steer the vehicle, or
 - c) has a hose, pump drive, drive belt, cylinder, including their mountings, that is insecure, damaged or significantly deteriorated, or
 - d) has any fluid leakage, except for minor seepage.
6. A **linkage or joint between the steering column shaft and steering box or rack**:
 - a) is insecure, or

Reasons for rejection

- b) is damaged, significantly corroded, distorted or cracked, or
 - c) shows signs of welding or heating after original manufacture, or
 - d) has play beyond manufacturer's specifications, or does not operate smoothly without roughness or stiffness, or
 - e) is fouling on the vehicle structure, wheel, tyre or brake system component.
7. The steering box or rack:
- a) is insecure, or
 - b) is damaged, significantly corroded, distorted or cracked, or
 - c) shows signs of welding or heating after original manufacture, or
 - d) has play beyond manufacturer's specifications, or
 - e) does not operate smoothly without roughness or stiffness, or
 - f) has an excessive fluid leak.
8. A steering rack gaiter is missing, insecure or split.
9. A steering linkage or joint (Note 2):
- a) is insecure, or
 - b) is damaged, significantly corroded, distorted or cracked, or
 - c) shows signs of welding or heating after original manufacture, or
 - d) has play beyond manufacturer's specifications, or
 - e) does not operate smoothly without roughness or stiffness, or
 - f) is fouling on the vehicle structure, wheel tyre or brake system component, or
 - g) shows signs of plastic injection.
10. A steering arm or associated component:
- a) is insecure, or

Reasons for rejection

- b) is damaged, significantly corroded, distorted or cracked, or
 - c) shows signs of welding or heating after original manufacture.
11. A kingpin or suspension joint (Note 2):
- a) is insecure, or
 - b) is damaged, significantly corroded, distorted or cracked, or
 - c) shows signs of welding or heating after original manufacture, or
 - d) has play beyond the manufacturer's specifications, or
 - e) does not operate smoothly without roughness or stiffness, or
 - f) shows signs of plastic injection.
12. A lock stop is loose or damaged.
13. A steering or suspension component mounting point:
- a) is insecure, or
 - b) has corrosion damage, buckling or fractures within 150 mm of a mounting point.
14. Any other suspension component:
- a) is insecure or missing, or
 - b) is damaged, significantly corroded, distorted or cracked, or
 - c) shows signs of welding or heating after original manufacture, or
 - d) has play beyond manufacturer's specifications, or
 - e) does not operate smoothly without roughness or stiffness, or
 - f) has excessive leakage of damping fluid, or
 - g) shows excessive play, roughness or stiffness in a strut upper support bearing, or
 - h) is a replacement urethane suspension bush that is not voided or shaped to allow for similar movement to an OE bush.

Reasons for rejection

15. There is corrosion damage (**Note 3**) within 150 mm of a suspension component mounting point.

Performance

16. During operation the forklift cannot be controlled in a safe, efficient convenient and sensitive manner, eg:
- a) the vehicle veers significantly to one side, or
 - b) the vehicle requires unreasonable force to steer, or
 - c) the steering is unreasonably stiff, rough or light, or
 - d) the vehicle does not handle safely under normal conditions of road use, eg the suspension is excessively hard or soft, or there is excessive body roll.

Note 1 Definition

Steering system means those components, parts and systems that connect the driver's controls to the vehicle's wheels or tracks by means of which the direction of motion of a vehicle is controlled.

Note 2 A damaged boot on a steering or suspension joint is not a ground for rejection; however, the vehicle's owner should be advised.

Note 3 Corrosion damage is where the metal has been eaten away, which is evident by pitting. The outward sign of such corrosion damage is typically displayed by the lifting or bubbling of paint. In extreme cases, the area affected by the corrosion damage will fall out and leave a hole.

Tyres, wheels and hubs

10-1 Tyres and wheels

Summary of legislation

Applicable legislation

- Land Transport Rule: Tyres and Wheels 2001

Mandatory equipment

Tyres

1. Tyres must be compatible with the vehicle to which they are fitted.
2. Tyres on the same axle must be of the same size designation and construction, and of the same tread pattern type.
3. Asymmetric tyres must be fitted in axle sets in accordance with manufacturer's instructions.
4. A unidirectional tyre must be fitted to a wheel position corresponding to its direction of rotation.
5. The speed category of a tyre must be compatible with the maximum legal speed limit for the vehicle, or the vehicle's maximum speed.
6. A forklift must not be fitted with a metal tyre or other non-pneumatic tyre (**Note 1**), or with a tyre with studs, cleats, lugs or other gripping devices.

Wheels

7. A wheel must be:
 - a) sufficiently strong for the type of vehicle to which it is fitted, and
 - b) compatible with the vehicle to which it is fitted, and
 - c) compatible with the tyre rim profile, flange height and valve fitment.
8. There must be adequate clearance for the brake, hub, suspension and steering mechanism, and body parts.

Permitted equipment

9. A forklift may be fitted with retreaded tyres.

Condition

Tyres (excluding spare tyres and space-saver tyres)

10. A tyre must be of good quality and construction, fit for its purpose and maintained in a safe condition.
11. A tyre must not have worn, damaged or visible cords apparent by external examination.
12. A heavy vehicle radial-ply tyre may have visible cords in the tyre tread area provided the tyre is in a safe condition. To assess whether such a tyre is in safe condition, the vehicle inspector may take into account written evidence from a person who has current specialist tyre knowledge and experience, particularly in heavy vehicle tyre inspection.
13. A tyre must have a tread pattern depth of not less than 1.5 mm (excluding any tie-bar or tread-depth indicator strip) around the whole circumference of the tyre:

Reasons for rejection

Mandatory equipment (see Note 2)

Tyres

1. Tyres on the same axle are not of the same:
 - a) size designation, or
 - b) construction type (ie mixed steel ply, fabric radial ply, bias/cross ply), or
 - c) tread pattern type (mixed asymmetric, directional, normal highway, traction).
2. An asymmetric tyre is fitted to a vehicle with the 'inside' tyre wall facing outwards.
3. A unidirectional tyre is fitted contrary to its correct direction of rotation.
4. A tyre has a speed category (**Table 10-1-1**) that is less than the speed limit for the vehicle or less than the vehicle's maximum speed if this is less than the speed limit (**Notes 3 and 4**).
5. The forklift has one or more of the following types of tyre fitted (**Note 1**):
 - a) a space-saver tyre, or
 - b) a metal tyre, or
 - c) a tyre with studs, cleats, lugs or other gripping devices.
6. A tyre is not compatible with the vehicle to which it is fitted, eg a tyre that is marked with any of the following:
 - a) 'FOR TRAILER USE ONLY'
 - b) 'ADV' (Agricultural Drawn Vehicle)
 - c) 'RACING PURPOSES ONLY'.

Wheels

7. A wheel is not compatible with the tyre fitted to it for rim profile, flange height or valve fitment.
8. A wheel is:
 - a) not compatible with the vehicle to which it is fitted.
or
 - b) not correctly attached to the vehicle.

Tyres, wheels and hubs

10-1 Tyres and wheels (cont.)

- a) within all principal grooves that contain tread-depth indicators, or
 - b) if the tyre does not normally have tread-depth indicators, across at least three-quarters of the tyre tread width.
14. The regrooving of a tyre is permitted only if the tyre is identified as being specifically designed for regrooving after manufacture.
15. A tyre that is fitted to a forklift must be maintained at a safe inflation pressure.

Spare tyre

16. If the forklift carries a spare tyre, the tyre must be securely attached on or in the vehicle.

Wheels

17. The components of the wheel assembly must be in good condition.
18. The wheel must be securely attached to the hub.

Reasons for rejection

Condition

Tyres (excluding spare tyres)

9. There are signs that a tyre is fouling on another part of the vehicle.
10. A pneumatic tyre shows damage that is likely to compromise its ability to operate in a safe manner or lead to premature tyre failure, such as:
- a) a lump or bulge that is likely to be caused by separation of the tyre structure, or
 - b) a cut or crack in a side wall or tread more than 25 mm long that reaches the cords (see **Note 5** for visible cords in the tread area of heavy vehicle radial-ply tyres), or
 - c) exposed or cut cords (see **Note 5** for visible cords in the tread area of heavy vehicle radial-ply tyres), or
 - d) the tread of a retreaded tyre shows signs of separation, or
 - e) nails or other sharp objects embedded in the tyre, or
 - f) significant perishing, eg due to age, moisture or exposure.
11. A pneumatic tyre has a string type repair visible from the outside.
12. A tyre is noticeably under- or over-inflated.
13. A non-pneumatic tyre is significantly disintegrated or shows signs that are likely to be the result of separation or partial failure of the tyre structure.
14. Tyre repairs have not been carried out in accordance with acceptable industry practice.
15. A tyre has insufficient tread to allow safe operation of the vehicle.

Spare tyres

16. A spare tyre, if carried, is not securely attached to or stored in the vehicle.

Wheels

17. There are signs that a wheel is fouling on another part of the vehicle.

Reasons for rejection

18. A wheel is:
- cracked, or
 - significantly damaged, distorted or has deteriorated, or
 - not securely attached to the hub.
19. A wheel nut is:
- missing, or
 - loose, or
 - deteriorated, or
 - the incorrect type, or
 - has insufficient thread engagement to the wheel stud.

Table 10-1-1. Tyre speed symbol categories

Speed symbol - speed category (km/h)							
A1 - 5	A5 - 25	B - 50	F - 80	L - 120	Q - 160	U - 200	Y - 300
A2 - 10	A6 - 30	C - 60	G - 90	M - 130	R - 170	H - 210	ZR - over 240
A3 - 15	A7 - 35	D - 65	J - 100	N - 140	S - 180	V - 240	
A4 - 20	A8 - 40	E - 70	K - 110	P - 150	T - 190	W - 270	

Note 1 A forklift may be fitted with non-pneumatic tyres such as solid rubber tyres or tyres filled with polyurethane.

Note 2 Definitions:

Asymmetric tyre means a tyre which, through tread pattern or construction, is required to be fitted to a vehicle so that one particular sidewall faces outwards.

Construction, in relation to a tyre, means

- for a pneumatic tyre, the type of carcass (including ply orientation and ply rating or load index)
- for any other tyre, characteristics relating to size, shape and material.

Cross ply means a pneumatic tyre structure in which the ply cords in the tyre carcass extend to the beads and are laid at alternate angles, which are substantially less than 90 degrees, to the centreline of the tread. This tyre structure is also referred to as 'bias ply' or 'diagonal ply'.

Directional tyre means a tyre with a tread pattern designed to operate in one direction only, and marked accordingly.

Pneumatic tyre means a tyre that, when in use, is inflated by air or gas introduced from time to time under pressure so as to enclose under normal inflation a cushion of air or gas forming altogether at least half of the total area of an average cross-section of a tyre so inflated.

Protective belt, sometimes called a protective ply or breaker, means an optional layer of ply material (cords) located immediately under the tread to minimise damage to the structural belts beneath.

Radial ply means a pneumatic tyre structure in which the ply cords, which extend from bead to bead, are laid at approximately 90 degrees to the centreline of the tread, the carcass being stabilised by an essentially inextensible circumferential belt.

Repair means to restore a damaged or worn vehicle, its structure, systems, components or equipment to within safe tolerance of its condition when manufactured, including replacement with undamaged or new structures, systems, components or equipment.

Tyres, wheels and hubs

10-1 Tyres and wheels (cont.)

Rim means that part of the wheel on which the tyre is mounted and supported.

Speed category means a code allocated to a tyre by a tyre manufacturer that indicates the maximum vehicle speed for which the use of the tyre is rated. It is either marked on the tyre or can be obtained from the tyre manufacturer or a reference guide.

Tube means an inflatable elastic liner, in the form of a hollow ring fitted with an inflation valve assembly, designed for insertion into certain tyre assemblies to provide a cushion of air or gas that, when inflated, supports the wheel (also known as an 'inner tube').

Tyre carcass means that structural part of a pneumatic tyre other than the tread and outermost rubber of the sidewalls that, when inflated, contains the gas that supports the load.

Tyre load rating means the maximum load a tyre can carry at the corresponding cold inflation pressure prescribed by the tyre manufacturer and the speed indicated by its speed category symbol.

Wheel means a rotating load-carrying member between the tyre and the hub, which usually consists of two major parts, the rim and the wheel disc, and which may be manufactured as one part, or permanently attached to each other, or detachable from each other.

Wheel centre-disc means that part of the wheel that is the supporting member between the hub and the rim.

Note 3 The tyre load index and speed category are usually marked on the tyre. Where the tyre is not marked, the load and speed rating information must be obtained from the tyre manufacturer or a reference guide of tyre ratings before the tyre can be passed.

Note 4 Sometimes a retreaded or repaired tyre has had its speed rating removed. Where a tyre has been repaired or retreaded in accordance with standard NZS 5423 (Repairing and retreading car, truck and bus tyres), the tyre must be marked with NZS 5423 and, if a car tyre, have the speed rating removed. In such a case, a missing speed rating is acceptable for WoF/CoF (unless the inspector believes on reasonable grounds that the tyre would not have had the required minimum speed rating for the vehicle in the first place).

Note 5 Where a heavy vehicle radial-ply tyre has visible cords in the tread area, the vehicle inspector may pass such a tyre for CoF provided the tyre is in a safe condition, eg only the protective cord layer (protective belt, see **Figure 10-1-1**) is visible. When determining whether such a tyre is in a safe condition, the vehicle inspector may take into account written evidence from a person who has current specialist tyre knowledge and experience, particularly in heavy vehicle tyre inspection.

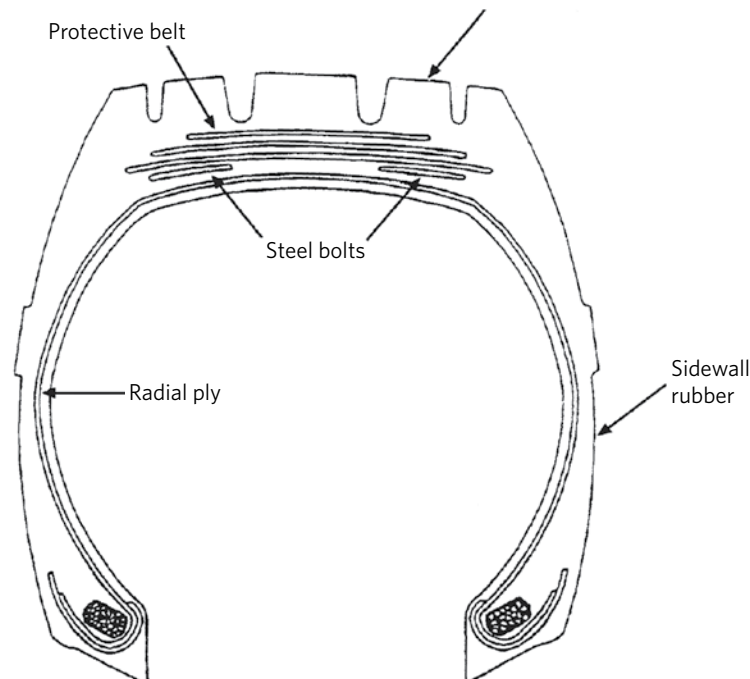

Figure 10-1-1. Cross-sectional representation of a heavy vehicle radial-ply tyre

Tyres, wheels and hubs

10-2 Hubs and axles

Summary of legislation

Applicable legislation

- Land Transport Rule: Tyres and Wheels 2001

Condition

1. The components of the assembly must be in good condition.
2. The hub and axle must be sufficiently strong for the type of vehicle to which they are fitted.
3. The hub and axle must have a suitable and correctly adjusted geometry.

Reasons for rejection

Condition

1. A hub (**Note 1**):
 - a) is not securely attached to the vehicle, or
 - b) has a visible crack, or
 - c) is significantly damaged, distorted or has deteriorated, or
 - d) has a broken or missing wheel stud.
2. A wheel bearing:
 - a) has play beyond the manufacturer's specifications, or
 - b) is over-tight or sounds rough.
3. An axle:
 - a) is insecure, eg has loose U-bolts, or
 - b) is visibly cracked, or
 - c) is significantly damaged, distorted or has deteriorated, or
 - d) shows signs of welding or heating after original manufacture, or
 - e) shows signs of fouling the vehicle structure or a brake, suspension or steering component.

Note 1 Hub means that part of a vehicle that is attached to the axle and rotates on, or with, the axle, and to which the wheel is attached, and includes any bearings.

Tyres, wheels and hubs**10-3 Mudguards****Summary of legislation****Applicable legislation**

- Land Transport Rule: Vehicle Equipment 2004

Permitted equipment

1. A forklift may be fitted with mudguards.

Condition

2. A mudguard must be securely fixed to the vehicle and must be constructed so that it does not present a hazard to road users.

Reasons for rejection**Mudguard condition**

1. A mudguard is not securely fixed to the vehicle.
2. A mudguard is so constructed or damaged that it is likely to present a hazard to road users.

Note 1 Mudguard means a fitting, inclusive of any portion of the vehicle and of any mudflaps attached, that serves to intercept material thrown up by a wheel more or less on the plane of the wheel.

Exhaust 11-1 Exhaust system

Summary of legislation

Applicable legislation

- Land Transport Rule: Vehicle Equipment 2004

Mandatory equipment

1. A forklift with an internal combustion engine must be fitted with an exhaust system (**Note 1**).

Condition

2. An exhaust system must not be constructed or modified in a way that allows a person to interfere readily with its operation or reduce its effectiveness.
3. An exhaust system must be designed, constructed, positioned and maintained in a way that minimises the risk of heat or fumes emitted from the system harming the vehicle's occupants.

Performance

4. An exhaust system must be effective and in good working order.
5. Noise from an exhaust system must not be noticeably and significantly louder than it would have been when the vehicle was manufactured with its original exhaust system.

Reasons for rejection

Mandatory equipment

1. A forklift is not fitted with an exhaust system that includes a means of sound reduction (**Note 1**).

Condition

2. An exhaust system is not securely mounted.
3. The exhaust system is so constructed or modified that its operation or effectiveness can be readily interfered with.
4. The exhaust system is so constructed that emitted heat or fumes are likely to harm vehicle occupants, eg the exhaust gases are not directed away from the perimeter of the vehicle's passenger compartment.

Performance

5. There is a leak of exhaust fumes from the exhaust system.
6. The noise output is noticeably and significantly louder than it would have been when the vehicle was manufactured with its original exhaust system.

Note 1 Exhaust system means a pipe assembly through which the engine exhaust gases pass to the atmosphere and includes some means of sound reduction such as a silencer or resonator.

Note 2 A spark arrestor is not required to be checked.

Exhaust

11-2 Visible exhaust smoke

Summary of legislation

Applicable legislation

- Land Transport Rule: Vehicle Exhaust Emissions 2007

Performance

1. A forklift must not emit clearly visible smoke (**Note 2**) when the engine is running at its normal operating temperature, under either of the following conditions:
 - a) for a continuous period of five seconds when the engine is idling, or
 - b) as the engine is being accelerated rapidly to approximately 2500 revolutions per minute or approximately half the maximum engine speed (whichever is lower).
2. Requirement 1 above does not apply if the driver of the forklift produces documentation that proves that the engine is original equipment for the vehicle and the engine's design does not allow the vehicle to reasonably comply.

Reasons for rejection

Performance

1. A forklift with the engine at normal operating temperature (**Note 1**), other than a forklift in Reason for rejection 2, emits clearly visible smoke (**Technical bulletin 8**) from the exhaust tail pipe (**Note 2**):
 - a) for a continuous period of five seconds when the engine is idling, or
 - b) as the engine is being rapidly accelerated to approximately 2500 rpm or approximately half the maximum engine speed (whichever is lower) (**Note 3**).
2. A forklift fitted with an engine that is designed in a way that the forklift cannot reasonably comply with Reason for rejection 1 emits smoke that is noticeably and significantly more visible than it would have been when the vehicle was manufactured and supplied with the recommended fuel (**Note 4**).

Note 1 Test procedure

- a) Carry out the idling and acceleration tests in Reason for rejection 1. A vehicle that passes both tests with the engine below normal operating temperature is deemed to have passed with the engine at normal operating temperature.
- b) If the vehicle has failed either test, ensure the engine is at normal operating temperature. Then purge the system by increasing the engine speed to 2500 rpm (or half the maximum engine speed if this is lower) and holding it there for about five seconds. Repeat the idling and acceleration tests in Reason for rejection 1.

Note 2 Visible emissions caused by the condensation of water vapour do not count as smoke.

Note 3 During the acceleration test, a diesel-powered vehicle may emit a moderate amount of smoke if this is caused by turbo lag.

Note 4 The vehicle inspector may need to take into account information from the vehicle manufacturer or their representative or other appropriate expert, eg about older or unusual forklifts.

Towing connections

12-1 Towing connections

Summary of legislation

Applicable legislation

- Land Transport Rule: Heavy Vehicles 2004
- Land Transport Rule: Vehicle Standards Compliance 2002, section 7.4

Permitted equipment

1. A forklift may be fitted with a towing connection.

Condition

2. Towing connection components fitted to a vehicle must ensure that a secure connection can be maintained between the towing and towed vehicles under all conditions of loading and operations for which the vehicle was constructed.
3. A vehicle must:
 - a) be safe to be operated, and
 - b) have been constructed using components and materials that are fit for purpose, and
 - c) be within safe tolerance of their state when manufactured.

Reasons for rejection

Condition

1. A towing connection component is:
 - a) not securely attached, or
 - b) missing, or
 - c) cracked, distorted or significantly corroded, or
 - d) worn beyond manufacturer's specifications.
2. A coupling mechanism or safety locking device does not operate smoothly or efficiently, or fasten securely.

Note 1 Corrosion damage is where the metal has been eaten away, which is evident by pitting. The outward sign of such corrosion damage is typically displayed by the lifting or bubbling of paint. In extreme cases, the area affected by the corrosion damage will fall out and leave a hole.

Note 2 Towing connection means the combination of components that enables one vehicle to tow or be towed by another vehicle; it includes a towbar, drawbar, drawbeam and coupling.

Miscellaneous items

13-1 Engine and drive train

Summary of legislation

Applicable legislation

- Land Transport Rule: Vehicle Standards Compliance Rule 2002, section 7.4

Condition and performance

- The vehicle must be safe to be operated.
- The components and materials must be fit for their purpose and within safe tolerance of their state when manufactured or modified.

Reasons for rejection

Condition

- The engine or gearbox is insecurely mounted.
- A driveshaft is bent or severely damaged.
- A driveshaft flange:
 - is insecure, or
 - has a bolt or nut missing.
- A driveshaft support bearing is:
 - insecure, or
 - worn beyond manufacturer's specifications.
- A driveshaft universal joint spider (cross) bearing:
 - is worn so that the movement in the joint is beyond manufacturer's specifications, or
 - caps have loose or missing cap bolts or circlips, or
 - is damaged, displaced or the seals on the spider journals are missing.
- A rubber doughnut-type driveshaft coupling:
 - is worn or damaged beyond manufacturer's specifications, or
 - is split or delaminated so that its mechanical integrity is affected, or
 - securing bolt is loose or missing.
- A driveshaft slip joint (spline) is worn beyond manufacturer's specifications.
- The universals in the driveshaft are not fitted in accordance with manufacturer's specifications.

Miscellaneous items **13-1 Engine and drive train (cont.)**

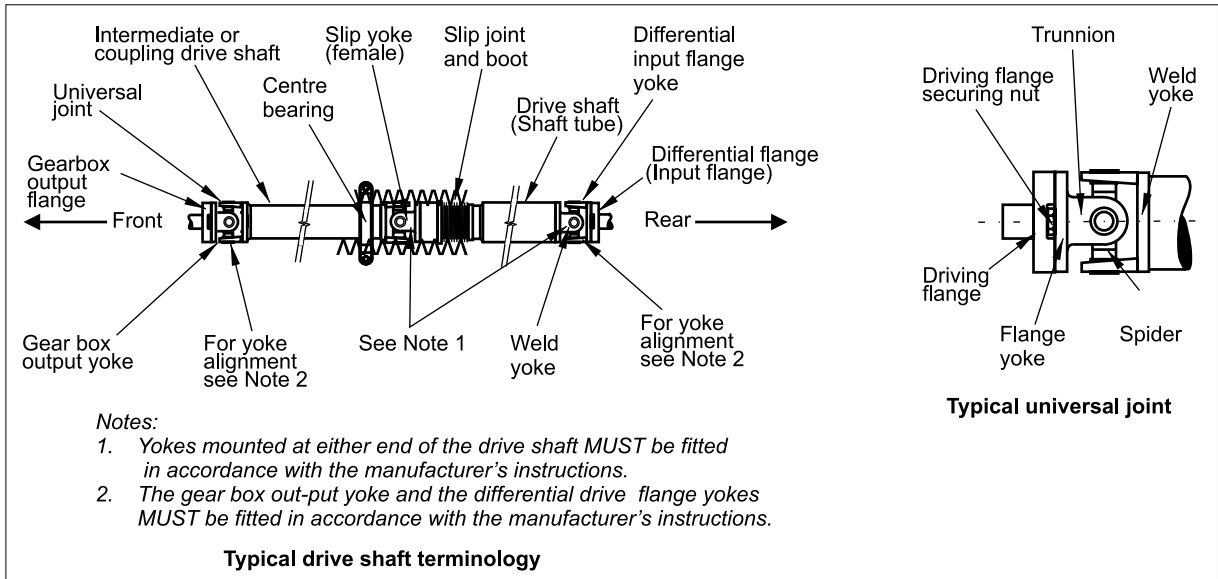

Figure 13-1-1. A typical driveshaft assembly

Miscellaneous items

13-2 Fuel system

Summary of legislation

Applicable legislation

- Land Transport Rule: Vehicle Equipment 2004

Condition and performance

1. Fuel tanks, fuel lines and associated components must be:
 - a) securely mounted, and
 - b) made of suitable materials, and
 - c) in good condition, and
 - d) free from significant leaks, and
 - e) positioned so that the risk of mechanical damage or heat gain is minimised.

Reasons for rejection

Condition

1. There is a noticeable fuel leak from the fuel system.
2. The security of the fuel tank is affected by:
 - a) corrosion damage (**Note 1**), or
 - b) cracking or other damage, or
 - c) insecure or loose tank mountings.
3. A fuel line is insecure or loose so that it is likely to get damaged during normal use of the vehicle.
4. A fuel pipe is severely damaged or excessively corroded.
5. A fuel hose is damaged or perished.
6. The fuel pump is insecure.
7. The fuel filler cap is missing, insecure or likely to allow fuel spillage when the vehicle is in normal use.
8. The fuel tank is fitted with a 'temporary use' fuel filler cap.

Note 1 Corrosion damage is where the metal has been eaten away, which is evident by pitting. The outward sign of such corrosion damage is typically displayed by the lifting or bubbling of paint. In extreme cases the area affected by corrosion damage will fall out and leave a hole.

Miscellaneous items

13-3 LPG/CNG fuel system

Summary of legislation

Applicable legislation

- Land Transport Rule: Vehicle Standards Compliance 2002
- Land Transport Rule: Vehicle Equipment 2004

Permitted equipment

1. A forklift may be fitted with an alternative fuel (LPG or CNG) system.

Condition

2. An LPG or CNG fuel system must be in safe working condition.

Reasons for rejection

Condition

1. An LPG or CNG fuel system component is:
 - a) loose, or
 - b) significantly corroded, distorted or cracked.
2. A gas line:
 - a) shows signs of corrosion damage (**Note 1**), such as pitting, or
 - b) is bulging, or
 - c) is insecure, or
 - d) is damaged, such as cut or crimped.
3. There is a noticeable gas leak.
4. There is corrosion damage, distortion or fracture within 300 mm of a tank mounting (this requirement is not applicable where the tank is mounted on the counterweight).

Note 1 Corrosion damage is where the metal has been eaten away, which is evident by pitting. The outward sign of such corrosion damage is typically displayed by the lifting or bubbling of paint. In extreme cases, the area affected by the corrosion damage will fall out and leave a hole.

Note 2 LPG/CNG fuel system means a fuel storage and conducting system that is used to provide liquid petroleum gas (LPG) or compressed natural gas (CNG) for the purpose of propulsion of a vehicle.

