

Land Transport Safety Authority  
of New Zealand

# Vehicle Inspection Requirements Manual Alternative Fuel System Certification



Holders of NZ Transport Agency PRS manuals must record amendments to this manual in the 'Technical information record' contained in the 'Master records' section of the PRS manual.

Amendment number	Date	Page numbers	Pages inserted by	Signature
			Name	



1	Purpose and scope	2		
2	Overview of the manual	3		
3	The inspection and certification process	5		
	3.1	Duties and responsibilities	5	
		3.1.1	General duties and responsibilities	5
		3.1.2	Inspection and certification	6
		3.1.3	Revocation of an Alternative Fuel Inspection Certificate	7
		3.1.4	Performance review	7
		3.1.5	Investigations	8
	3.2	Establishing whether the vehicle requires alternative fuel system inspection and certification	10	
	3.3	Establishing whether the vehicle may be inspected for alternative fuel system inspection and certification	11	
	3.4	Establishing whether the vehicle complies	11	
	3.5	Checksheets	12	
	3.6	Issuing the Alternative Fuel Inspection Certificate	14	
		3.6.1	Expiry dates	14
		3.6.2	Completing and affixing the Alternative Fuel Inspection Certificate	14
	3.7	Collecting fees	15	
4	Complaints	17		
5	Inspection premises and equipment	18		
	5.1	Premises specifications	18	
		5.1.1	Access and exit specifications	18
		5.1.2	Inspection area specifications	18
		5.1.3	Minimum under-body inspection area specifications	19
		5.1.4	Equipment	19
		5.1.5	Compliance with statutory requirements	20
6	Appointments	20		
	6.1	Vehicle inspectors	20	
	6.2	Inspecting organisations	20	
7	Definitions and abbreviations	22		
8	Sample certification documents	25		
9	Improvement suggestion form	29		

The New Zealand Transport Agency (NZTA) has prepared this document to assist vehicle inspectors and inspecting organisations achieve correct and consistent standards of alternative fuel system inspection and certification.

The purpose of this manual is to enhance the safety of in-service vehicles in New Zealand by conveying to the NZTA appointed vehicle inspectors and inspecting organisations the conditions of their appointment and the requirements for the inspection and certification of vehicles for operation in-service.

The scope of this manual is to set out the statutory requirements for in-service alternative fuel system inspections. This manual is restricted to the in-service vehicle inspection requirements for vehicles fitted with alternative fuel systems using compressed natural gas (CNG) and liquefied petroleum gas (LPG). Vehicles may be inspected for alternative fuel system certification only if the system uses gas for the propulsion of the vehicle. Alternative fuel systems driving auxiliary engines or other equipment may not be inspected for alternative fuel system certification.

Additional manuals are available from:

Driver and Vehicle Certification Unit  
Transport Registry Centre  
NZ Transport Agency  
PO Box 11 777  
Palmerston North 4442  
Fax: 06 953 6282  
Phone: 0800 587 287

Amendments to this manual will be issued from time to time as inspection requirements change and improvements are made. Suggestions for improvement should be made using the form provided at the end of this introduction.

**The manual is structured into four main parts:**

## 1. Introduction

The introduction explains the duties and responsibilities of the inspecting organisation and vehicle inspector, the inspection and certification process, complaints procedures, inspection premises and equipment, and the appointment of vehicle inspectors and inspecting organisations. It also includes definitions and abbreviations, sample certification documents and an improvement suggestion form. The introduction is relevant to all vehicles requiring alternative fuel system inspection and certification.

## 2. LPG fuel system inspection and certification

This part of the manual covers the requirements for vehicles that use LPG for propulsion.

## 3. CNG fuel system inspection and certification

This part of the manual covers the requirements for vehicles that use CNG for propulsion.

For each inspection item, the inspection requirement pages are mostly divided into two columns. These columns are then broken up into **Mandatory equipment, Permitted equipment, Condition, and Performance**.

The Summary of legislation column summarises the legislation that is relevant to in-service inspection and certification.

The Reasons for rejection column specifies the vehicle defects that must result in the vehicle being rejected for alternative fuel system certification. The condition and performance reasons for rejection apply to mandatory, permitted, and modified equipment, unless otherwise stated. The Director has imposed these requirements in accordance with Land Transport Rule: Vehicle Standards Compliance 2002, subclause 2.3(1).

Outside the two columns are tables, notes, and illustrations for additional guidance, as referred to in the columns.

## 4. Technical bulletins

These may be issued if more lengthy explanation is required to cover such things as individual vehicle models, specific inspection items and so on.

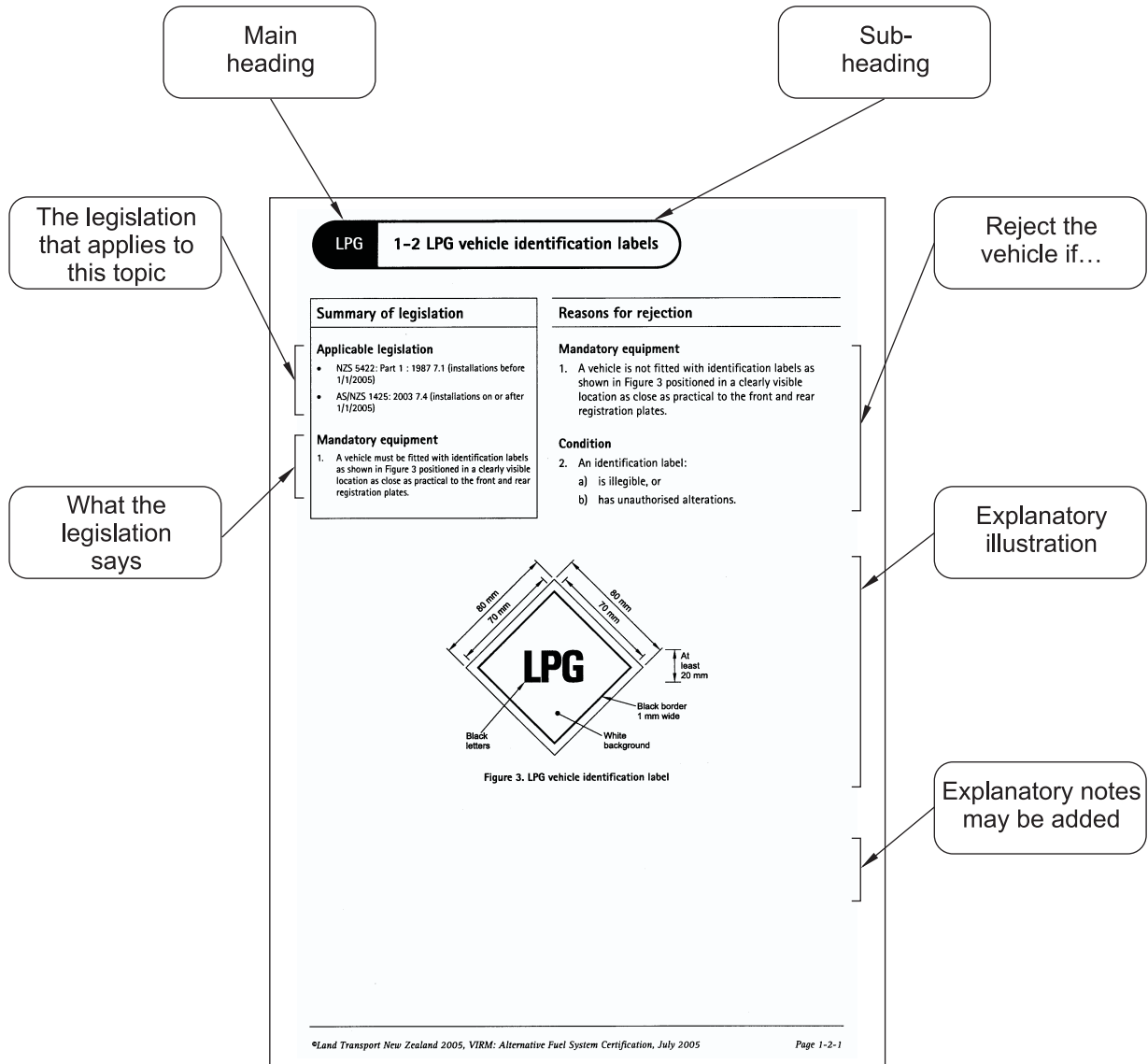

Figure 1. Layout of pages in the manual

In order to inspect and certify a vehicle for alternative fuel certification the vehicle inspector and inspecting organisation must take the following steps:

1. Know the vehicle inspector's and inspecting organisation's responsibilities (subclause 3.1).
2. Identify whether the alternative fuel system requires an Alternative Fuel Inspection Certificate (subclause 3.2)
3. Establish whether the alternative fuel system may be inspected for alternative fuel system certification (subclause 3.3)
4. Establish whether the alternative fuel system complies. Subclause 3.4 explains how to use this manual in order to determine the vehicle's compliance with the requirements.
5. Complete the record of determination (checksheet) (subclause 3.5)
6. Issue the Alternative Fuel Inspection Certificate label (subclause 3.6)
7. Collect fees (subclause 3.7)

### 3.1 Duties and responsibilities

#### 3.1.1 General duties and responsibilities

Applicable legislation: Vehicle Standards Compliance Rule 2002 (the Rule).

##### 1. Vehicle inspectors and inspecting organisations [Definitions in the Rule]

Vehicle inspector means an individual appointed by the Director [of Land Transport] under 2.2(1) [of the Rule] to carry out inspection and certification activities in accordance with requirements and conditions imposed by the Director.

Inspecting organisation means a person or organisation appointed by the Director under 2.2(1) who is responsible for inspection and certification outcomes.

##### 2. Inspection and certification activities [subclause 2.1(1) of the Rule]

Only vehicle inspectors and inspecting organisations appointed by the Director of Land Transport may carry out inspection and certification activities as specified in Land Transport Rule: Vehicle Standards Compliance 2002.

##### 3. Primary duty [subclause 2.1(2) of the Rule]

Vehicle inspectors and inspecting organisations must carry out inspection and certification activities competently and diligently and in accordance with Land Transport Rule: Vehicle Standards Compliance 2002 and with this manual.

##### 4. Inspection and certification activities that can be carried out [subclause 2.2(2) of the Rule]

Vehicle inspectors and inspecting organisations may carry out only those inspection and certification activities for which the Director of Land Transport has appointed them.

##### 5. Requirements, conditions, and period of appointment [subclause 2.3(1) of the Rule]

The Director may specify the period of appointment for a vehicle inspector and inspecting organisation and may impose requirements and conditions as to the performance of the inspection and certification activities, including the performance of those activities at individual sites.

## 6. Fit and proper person [subclause 2.3(3) of the Rule]

It is a condition of an appointment that a vehicle inspector or inspecting organisation continues to be fit and proper.

## 7. Document retention, Advise incorrect certification, Advise vehicle defects [subclause 2.3(4) of the Rule]

It is a condition of an appointment that a vehicle inspector or inspecting organisation:

1. keep all records and associated documents relating to vehicle inspections and certifications for a minimum period of 12 months, and
2. advise the VCU as soon as practicable if there is a reason to believe that the inspection and certification of a vehicle has been carried out incorrectly, and
3. advise the VCU as soon as practicable of a defect in a manufacturer's production run or quality control process of which the inspector or organisation has become aware that may affect the safety performance of a vehicle that has been inspected and certified.

## 8. Delegation [subclause 2.4(1) of the Rule]

A vehicle inspector or inspecting organisation may not delegate any function or power to carry out inspection and certification activities for which they were appointed, except under conditions specified by the Director in writing.

### 3.1.2 Inspection and certification

#### 1. Alternative fuel inspection and certification [subclause 7.3(3) of the Rule]

The inspection and certification of a vehicle for operation in-service must be carried out in accordance with requirements and conditions imposed by the Director.

**IMPORTANT:** This manual contains the Director's requirements and conditions.

#### 2. Determining compliance of a vehicle's alternative fuel system [section 2 of the Rule, clause 7.4 of the Rule and TR76 reg 90K(2)(a)–(c)]

A vehicle's alternative fuel system may be certified for operation in-service only if a vehicle inspector or inspecting organisation has identified the vehicle and has determined, on reasonable grounds, that the vehicle's system meets all of the following:

1. the system is safe to be operated under normal conditions of use, and
2. the system has been designed and constructed using components and materials that are fit for their purpose, and is within safe tolerance of its state when manufactured or modified, and
3. every component of the alternative fuel system and the system as a whole is in a safe working condition, and
4. the system fully complies with the applicable requirements and the Director's imposed conditions and requirements in this manual.

### **3. Information to take into account when determining compliance of a vehicle [subclause 7.4(3) of the Rule]**

A vehicle inspector or inspecting organisation, in making a determination, must take into account:

- a) information obtained from inspecting the vehicle and associated documents, and
- b) additional relevant information, if any, about the vehicle issued by a manufacturer, modifier, repairer, or other relevant person of which the inspector or organisation is aware.

### **4. LPG and CNG fuel system specialist certification [clause 7.2(b)(v) & 7.5(1)(ba) of the Rule]**

A vehicle that, since it was last issued with an alternative fuel inspection certificate, has been modified in a way that affects the LPG or CNG fuel system must undergo alternative fuel system specialist inspection and certification.

**Note:** An alternative fuel installation certificate and an alternative fuel installation compliance plate are evidence of LPG or CNG fuel system specialist inspection and certification.

#### **3.1.3 Revocation of an Alternative Fuel Inspection Certificate**

##### **1. Revocation of evidence of vehicle inspection and conditional permit [subclause 11.3(1) of the Rule]**

The Director may revoke, by giving written notice to a vehicle's operator, an Alternative Fuel Inspection Certificate issued under Land Transport Rule: Vehicle Standards Compliance 2002 if the Director believes, on reasonable grounds, that:

- a) the vehicle does not comply with applicable requirements, or
- b) the Alternative Fuel Inspection Certificate was issued on the basis of an incorrect determination.

##### **2. Re-inspection and re-certification of a vehicle [clause 11.4 of the Rule]**

If an Alternative Fuel Inspection Certificate has been revoked, the Director may require in writing that a vehicle inspector or inspecting organisation:

- a) repeat the inspection and certification of the vehicle, and
- b) issue, if appropriate, an Alternative Fuel Inspection Certificate, and
- c) meet the costs of the activities undertaken under (a) and (b).

#### **3.1.4 Performance review**

##### **1. Director may monitor and review performance [subclause 3.1(1) of the Rule]**

The Director may monitor and review the performance of a vehicle inspector or inspecting organisation in complying with the requirements and conditions imposed by the Director, including the performance of inspection and certification activities at individual sites.

The requirements and conditions are contained in this manual and in the Performance Review System Manual.

##### **2. Providing information to the Director [subclause 3.1(2) & (3) of the Rule]**

In monitoring and reviewing performance, the Director may require a vehicle inspector or inspecting organisation to undergo such monitoring and review and provide such information as the Director reasonably considers relevant. A vehicle inspector or inspecting organisation must comply with a requirement from the Director.

### 3. Costs of monitoring and review [subclause 3.1(4) of the Rule]

A vehicle inspector or inspecting organisation must bear the costs of the monitoring and reviewing of their performance in accordance with any prescribed fee.

#### 3.15 Investigations

##### 1. Investigations [subclause 3.2(1) of the Rule]

If the Director has reason to believe that a vehicle inspector or inspecting organisation has failed to comply with any of the conditions of their appointment, or has failed to comply with Land Transport Rule: Vehicle Standards Compliance 2002 (the Rule) or with this manual, the Director may require the inspector or organisation to undergo such an investigation and to provide such information as the Director reasonably considers appropriate.

##### 2. Notification of action (remedial action, suspension or revocation, but not immediate suspension or imposing of conditions) [subclause 3.2(3) of the Rule]

Following an investigation and before carrying out action, the Director must notify the vehicle inspector or inspecting organisation in writing of:

- a) the action that is being considered, and
- b) the reasons for the action that is being considered, and
- c) the date by which submissions may be made to the Director in respect of the action that is being considered, which must be at least 21 days after the notice was given, and
- d) where appropriate, the date on which the action that is being considered will take effect, which unless the Director determines otherwise, must be at least 28 days after the notice was given.

##### 3. Responding to a notification of action [subclause 3.2(5) of the Rule]

If a vehicle inspector or inspecting organisation is notified as above, they must ensure that all information that they wish the Director to consider in relation to the action that is being considered is received by the Director within the period specified in the notice or within any further period that the Director may allow.

##### 4. Director must consider submissions [subclause 3.2(6) of the Rule]

The Director must consider the submissions made and information supplied, and must:

- a) decide whether or not to take the action that is being considered, and
- b) as soon as is practicable, provide written notification to the vehicle inspector or inspecting organisation of:
  - the Director's decision, and
  - if appropriate, the date on which the action is to take effect, and
  - if appropriate, the right of appeal under section 106 of the Land Transport Act 1998.

##### 5. Remedial action, suspension, revocation [subclause 3.2(2) of the Rule]

If, following an investigation, the Director is satisfied that the vehicle inspector or inspecting organisation has failed to comply with any of the conditions of their appointment, or failed to comply with the Rule or this manual, the Director may do one or more of the following:

- a) require that remedial action, such as training, be undertaken by the inspector or organisation

- b) suspend the whole or any part of the appointment of the inspector or organisation for a specified period or until specified conditions are met
- c) revoke the whole or any part of the appointment of the inspector or organisation.

#### **6. Immediate suspension or imposing of conditions [subclause 3.3(1) of the Rule]**

If the Director has reason to believe that a vehicle inspector or inspecting organisation has failed to comply with a condition of their appointment or with the Rule or this manual, and that this presents a significant risk to land transport safety, the Director may suspend, with immediate effect, the whole or any part of the appointment, or impose any conditions on the appointment.

#### **7. Notification of immediate suspension or imposing of conditions [subclause 3.3(2) of the Rule]**

Where the Director suspends the whole or any part of an appointment, or imposes conditions on the appointment, the Director must notify the vehicle inspector or inspecting organisation in writing of:

- a) the grounds for the suspension or imposing of conditions
- b) the fact that the inspector or organisation may make submissions to the Director
- c) the right of appeal under section 106 of the Land Transport Act 1998.

#### **8. Director must consider submissions following immediate suspension or imposing of conditions [subclause 3.3(3) of the Rule]**

The Director must, as soon as practicable, consider any submission made and notify the inspector or inspecting organisation in writing of the result of any such consideration.

#### **9. Duration of immediate suspension or imposing of conditions [subclause 3.3(5) of the Rule]**

A suspension or condition imposed remains in force until the Director has determined the action to be taken and that action has been taken.

#### **10. Withdrawal of immediate suspension or imposing of conditions [subclause 3.3(4) of the Rule]**

The Director may at any time withdraw a suspension or condition imposed.

#### **11. Right of appeal [subclause 3.3(6) of the Rule]**

A vehicle inspector or inspecting organisation may appeal under section 106 of the Land Transport Act 1998 against a decision by the Director to immediately suspend or impose conditions.

#### **12. Costs of investigations [subclause 3.2(7) of the Rule]**

The Director may require a vehicle inspector or inspecting organisation to bear the costs associated with an investigation or remedial action in accordance with any prescribed fee.

#### **13. Obligation to comply [subclause 3.2(8) of the Rule]**

A vehicle inspector or inspecting organisation must comply with a requirement of the Director in relation to paragraphs 1, 5, and 12.

### 3.2 Establishing whether the vehicle requires alternative fuel system inspection and certification (Rule 7.2(b)(v))

An Alternative Fuel Inspection Certificate is required for any vehicle fitted with an alternative fuel system that is in working order before it can be issued with a WoF or CoF.

**Note: An alternative fuel system with all the necessary components connected is deemed to be in working order, whether or not it is charged. A system that has had the filler connection removed is deemed to be not in working order.**

The following vehicles do not require alternative fuel system inspection and certification:

1. forklifts, floor sweepers, polishers, tow tractors, elevating work platforms, industrial stationary engines, other LP Gas usage such as the gas supply system for appliances in caravans, mobile homes, or for the propulsion of marine craft
2. any motor vehicle owned by a harbour board, shipping company or stevedoring contractor and used exclusively in connection with the embarking of ships' passengers or for loading and unloading ships' mails, cargo and passenger baggage and used on a public highway only when proceeding unladen from one wharf to another wharf or from its usual place of storage to a wharf and in returning to that place of storage
3. any motor vehicle normally propelled by mechanical power while it is being temporarily towed without the use of its own power.
4. vehicles listed in the table below:

a) a vehicle of class AB, LA or LB that does not have a motor or motors with a total power output of more than 2 kW, and is not operated at a speed exceeding 50 km/h	h) a trailer designed exclusively for agricultural purposes and not operated except when being: <ol style="list-style-type: none"> <li>i) delivered from a manufacturer to the manufacturer's agent, or</li> <li>ii) taken to or from an agricultural show for display or demonstration purposes, or</li> <li>iii) taken from one part of a farm to another part of that farm, or from one farm to another farm owned or managed by the same person, or</li> <li>iv) taken to or from a farm by an agricultural contractor for the purpose of cultivation or harvest other than operations connected with the logging of trees and the cartage of fertiliser or lime or bulk liquids, or</li> </ol>	j) an all-terrain vehicle used: <ol style="list-style-type: none"> <li>i) in moving from the operator's place of residence to a road that is not a public highway, when the distance travelled is less than 3 km, or</li> <li>ii) in connection with its inspection, servicing or repair, or</li> <li>iii) as an agricultural vehicle</li> </ol>
b) an armoured vehicle used exclusively as equipment of the New Zealand Defence Force		
c) a traction engine		
d) a mechanically-propelled roller		
e) a crane fitted with self-laying tracks		
f) an excavator fitted with self-laying tracks		
g) a tractor or any other machine used solely in agricultural, land management or roading operations, whether for traction or otherwise, that is not operated at a speed exceeding 30 km/h, together with any trailer operated only while being towed by that tractor or machine	i) a vehicle normally propelled by mechanical power while it is being temporarily towed without the use of its own power	

### **3.3 Establishing whether the vehicle may be inspected for alternative fuel system certification**

Before a vehicle can be inspected for the purpose of alternative fuel system certification it must meet one of the following requirements:

- a) the number on the registration plate(s) must be the same as that stated on the licence label, and the label must correctly describe the vehicle and be current, or
- b) the number on the registration plate(s) must be the same as that stated on the licence label, and the label must correctly describe the vehicle and must not have been expired for more than 12 months or the vehicle de-registered.

### **3.4 Establishing whether the vehicle complies**

1. Select the CNG or LPG section of this manual depending on which fuel system is installed in the vehicle.
2. Inspect and test the alternative fuel system to determine whether it complies with the requirements set out in this manual, including clause 3.1.2.2.
3. The vehicle inspector or inspecting organisation may refuse to inspect a vehicle which:
  - a) is presented in such a condition that inspection is unreasonably difficult or cannot be completed (components missing, covered in dirt, etc) or
  - b) has an insecure load.
4. The alternative fuel system complies when it has been inspected according to this manual and the alternative fuel inspector determines that no reasons for rejection apply and that it meets all the requirements in 3.1.2(2). The vehicle inspector must pass the vehicle for certification.
5. The alternative fuel system does not comply when it has been inspected according to this manual and the alternative fuel inspector determines that a reason for rejection applies or that it does not meet a requirement in 3.1.2(2). The vehicle inspector must reject the vehicle for certification.
6. Where the inspector requires further information in order to determine compliance with the requirements, the inspector must not certify the vehicle until the information has been obtained.

### 3.5 Checksheets

Applicable legislation: Land Transport Rule: Vehicle Standards Compliance 2002, clause 2.3

1. A checksheet that provides an adequate record of inspection must be used. Checksheet requirements are shown in Table 1 below.
2. The checksheet must be completed in full and the writing must be clearly legible on the original and the duplicate page.
3. Where parts of an alternative fuel system are inspected by different people, all those inspecting the vehicle must be alternative fuel inspectors. The checksheet must record which inspector inspected which part of the system. One inspector must take overall responsibility for the inspection of the alternative fuel system and that inspector must sign the checksheet.
4. An alternative fuel inspector can determine one of two outcomes:
  - a) Passed inspection: Record the determination on the checksheet and issue an Alternative Fuel Inspection Certificate.
  - b) Failed inspection: Record the determination on the checksheet. The reasons for the failed inspection must be clearly stated on the checksheet.
5. The customer copy of the completed checksheet must be supplied to the vehicle owner or operator.

The inspecting organisation copy is retained by the inspecting organisation.

**Table 1. Alternative Fuel Inspection Certificate checksheet requirements**

<b>Requirements for an Alternative Fuel Inspection Checksheet</b>
<p><b>Requirements</b></p> <ol style="list-style-type: none"> <li>1. A checksheet must be authorised by the NZTA Driver and Vehicle Certification Unit Technical Coordinator before use.</li> <li>2. An authorised NZTA logo in bottom right corner with the words 'Authorised by' above it. Authorised use of the logo may be arranged with NZTA Communications.</li> <li>3. An area of at least 100 cm<sup>2</sup> for comments by the Vehicle Inspector.</li> <li>4. Unique numbering of each checksheet.</li> <li>5. Wording as specified below.</li> <li>6. Information items as specified below.</li> <li>7. Pass/fail items as specified below.</li> <li>8. A copy of the printed checksheet must be supplied to the NZTA Driver and Vehicle Certification Unit for their records.</li> </ol> <p><b>Wording to be included</b></p> <ol style="list-style-type: none"> <li>1. The words: 'This checksheet does not constitute an Alternative Fuel Inspection Certificate'</li> <li>2. Words to the effect that rechecks must take place within 28 days of the original inspection, and that after this time a new inspection must be carried out and a new fee paid.</li> <li>3. The words: 'Complaints regarding alternative fuel inspection issues should be first directed to the Alternative Fuel Inspection Certificate issuer'. Additional words may be added to the checksheet to meet the requirements for complaint statements contained in the Introduction in the VIRM: Alternative Fuel System Certification.</li> <li>4. The words: 'The NZTA reserves the right to recheck any vehicle following an inspection.'</li> </ol>

### Items to be on the checksheet

The checksheet shall contain the items of information to be recorded and the list of inspection items to be checked by the Vehicle Inspector.

The items on the checksheet may be listed in any order, but inspection items must be numbered so that comments are easily referenced.

Each inspection item on this list shall have a PASS/FAIL or YES/NO indicator, which must be marked by the Vehicle Inspector after each item is checked.

The method of indicating PASS, FAIL and NOT APPLICABLE, shall be explained on the checksheet.

The inspection items that must be recorded on a checksheet when carrying out an alternative fuel system inspection are listed below in the order in which they appear in the *VIRM: Alternative Fuel System Certification*. Any additional items included must be relevant to the inspection requirements in the *VIRM: Alternative Fuel System Certification*. The checksheet must state if an item is not an inspection requirement.

### Information items

- Customer name and address
- Inspecting Organisation trading name and address
- Inspecting Organisation authority number
  
- Make
- Model
- Odometer reading
- Year
- Year first registered in NZ
- Registration No
- Chassis No/VIN
- Fuel type
  
- Inspection date
- Vehicle Inspector Authority No
- Vehicle Inspector's signature
- Indication of vehicle inspection pass or fail
  
- Re-inspection date
- Vehicle Inspector Authority No
- Vehicle Inspector's signature
- Indication of vehicle inspection pass or fail
  
- Alternative Fuel inspection Certificate expiry date
- Alternative Fuel inspection Certificate No.

### Pass/fail items

#### LPG

- Alternative fuel installation certification
- LPG vehicle identification labels
- Container
- Container attachment
- Container fittings
- Gas proof compartment
- Dual-fuel selector
- Filler connection
- Hydrostatic relief valve
- Safety valve system

- Location and ground clearances
- Liquid filters
- Fuel service line
- System gastightness

**CNG**

- Alternative fuel installation certification
- CNG vehicle identification labels
- Cylinder
- Cylinder attachment
- Fuel system components
- Cylinder compartment
- Location and ground clearances
- Fuel service line
- System gastightness

**3.6 Issuing the Alternative Fuel Inspection Certificate (Rule 7.9 and 9)**

Applicable legislation: Land Transport Rule: Vehicle Standards Compliance 2002, subclause 7.9 and clause 9

**3.6.1 Expiry dates**

The expiry date is whichever occurs first of the following:

1. twelve months from the date of passed inspection, plus up to 14 days of the unexpired portion of the existing certificate, or
2. the first date on which a cylinder or container is due to be tested.

**3.6.2 Completing and affixing the Alternative Fuel Inspection Certificate**

If the vehicle passes the alternative fuel inspection, the new Alternative Fuel Inspection Certificate must be completed in the following manner:

Front side: select the label with the correct month of expiry and record the full expiry date of the inspection certificate.

The diagram illustrates the details of the Alternative Fuel Inspection Certificate label, showing three views: Label record (butt), Label reverse, and Label front.

**Label record (butt):** Contains the registration number (No. 128502), Regd No., Make, Fuel Type, Name of Owner, Address, Date of Examination, and Expiry Date. A note states: "The expiry date is to be 12 calendar months from the date of examination (plus up to 14 days of the unexpired portion of any previous certificate) or the date before which the next fuel cylinder test is due, whichever is the sooner."

**Label reverse:** Contains the registration number (No. 128502), Regd No., Make, Fuel Type, Expiry Date, Installation Certificate No., Authorised Agency, and Authorised Agency No.

**Label front:** Features a grid pattern, the text "Alternative Fuel Certificate", the MAR logo, and "Expires / /".

Labels and arrows point to the following fields:

- Unique serial number
- Vehicle registration number
- Vehicle make
- Fuel type (LPG or CNG)
- Month the certificate expires
- Full expiry date of the Inspection Certificate
- Installation Certificate number
- Name of the Inspecting Organisation
- Inspecting Organisation number ('AVIC ID')
- Signature and number of vehicle inspector

**Figure 2. Alternative Fuel Inspection Certificate details**

Reverse side: record all the following items:

1. vehicle registration number
2. vehicle make
3. fuel type
4. full expiry date of the inspection certificate
5. Alternative Fuel Installation Certificate number
6. name of the inspecting organisation (Authorised Agency)
7. number ('AVIC ID') of the inspecting organisation (Authorised Agency).

Label record (butt): record all of the following:

1. vehicle registration number
2. vehicle make
3. fuel type
4. name of vehicle owner
5. date of passed inspection
6. full expiry date of the inspection certificate
7. signature and authority number of the vehicle inspector.

Each label has a unique number which must be recorded on both copies of the checksheet.

The label record (butt) must be held by the inspecting organisation.

### **Affixing the Alternative Fuel Inspection Certificate**

The Alternative Fuel Inspection Certificate must be affixed by the vehicle inspector or a delegated employee of the inspecting organisation in one of the following positions:

1. If the vehicle is fitted with a windscreen:
  - a) to the inside of the windscreen facing outwards, on the same side as the steering wheel, and
  - b) as close as possible to the edge of the windscreen where it is clearly visible from the outside and is not obscured by the anti-glare band.
2. For any other vehicle, in a position where it can be readily seen.

Not more than one Alternative Fuel Inspection Certificate may be displayed at one time. When issuing a new certificate, the vehicle inspector must remove the existing label.

### **3.7 Collecting fees**

Applicable legislation: Land Transport (Certification and Other Fees) Regulations 1999, Regulations 7 and 8.

**Application for inspection and certification of vehicles for alternative fuel certification**

The fee to be paid by an applicant for inspection and certification of a vehicle for in-service inspection (including alternative fuel system inspection) is the amount fixed by the inspecting organisation that is reasonable, having regard to:

- a) the time spent in inspecting the vehicle to ascertain whether it complies with the relevant requirements, and
- b) any fees payable to Land Transport NZ, and
- c) any standard or usual rate at which the inspecting organisation imposes charges for other work carried out in respect of motor vehicles.

Where a vehicle subject to a Warrant of Fitness fails an alternative fuel system inspection, no additional fee is payable for any subsequent inspection by the same inspecting organisation for the purpose of the same certification, if such application is made within 28 days of the first inspection for the issue of the evidence of vehicle inspection. A fee is payable for an inspection if the vehicle is presented after the 28 days have lapsed.

**Duplicate evidence of vehicle inspection**

The fee to be paid by the vehicle operator to an inspecting organisation for a duplicate of an evidence of vehicle inspection (label) is \$7.50 including GST., which is set by regulation. A duplicate can be issued only if evidence of the original inspection and certification, such as a checksheet, is made available to the inspecting organisation issuing the duplicate certificate.

Customers should be encouraged to direct any complaints to the inspecting organisation in the first instance.

To ensure all written complaints received are investigated, the inspecting organisation must maintain an effective complaints management process, which must meet the following requirements:

1. A clear and concise statement that recognises the positive value of complaints.
2. Clear and concise instructions to all customers on how to register a complaint. This can be accomplished in several ways, eg:
  - a) a conspicuous notice on the work-place wall, or
  - b) a clear statement on any receipt or invoice issued, or
  - c) a clear statement on the inspecting organisation's checksheet.
3. A straightforward explanation of the expected standards for resolution and the customer's right to appeal to Land Transport NZ if they are dissatisfied with the proposed resolution.
4. Documentation of any investigation into a complaint prepared in accordance with the *PRS Manual* so that details of the investigation can be readily checked.
5. Acknowledgment of all written complaints in writing within three working days, and the investigation completed and a resolution proposed to the complainant within 20 working days of the complaint being made.
6. A record of all complaints, both verbal and written, in accordance with the *PRS Manual*.
7. Directions for any customer who wishes to make a complaint or appeal a decision made by an inspecting organisation to contact the Land Transport NZ Helpdesk 0800 699 000.

The inspecting organisation must continue to comply with the applicable requirements in this section and maintain their premises and equipment in a good state of repair at all times.

## 5.1 Premises specifications

### 5.1.1 Access and exit specifications

#### Minimum dimensions<sup>1</sup>

Specification	Light vehicles (passenger vehicles and vans)	Heavy vehicles
Width of access to and exit from the inspection area	2.8 m	3.0 m
Height of access to and exit from the inspection area	2.6 m	4.5 m

<sup>1</sup> Where these dimensions cannot be met, smaller dimensions may be considered for approval on a case by case basis.

#### Other requirements and considerations

- The ground must be even and level, (the ground will be considered level when it can be demonstrated that all vehicle combinations will remain stationary with all brakes released).
- The ground must be constructed of a material that will remain firm in all weather conditions.

### 5.1.2 Inspection area specifications

#### Minimum dimensions<sup>1</sup>

Specification	Light vehicles (passenger vehicles and vans)	Heavy vehicles
Inspection area width	3.5 m	5.0 m
Inspection area height	3.0 m	5.0 m
Inspection area length	6.0 m	12.0 m

<sup>1</sup> Where these dimensions cannot be met, smaller dimensions may be considered for approval on a case by case basis. Similarly, where larger vehicles are likely to be inspected, the dimension requirements may need to be increased to allow for a comfortable and safe inspection.

#### Other requirements and considerations

- The inspection area must be situated within a building, which has a roof, sides, and doors made of permanent building materials.
- The inspection area shall be clear of all structural and equipment intrusions apart from a vehicle hoist where used.
- The inspection area floor must be smooth concrete or tar seal.
- The ground must be even and level, that is, when it can be demonstrated that all vehicle combinations will remain stationary with all brakes released.
- There must be sufficient suitable lighting in the inspection area.

### 5.1.3 Minimum under-body inspection area specifications

Specification At least one of the following as applicable		Light vehicles (passenger vehicles and vans)	Heavy vehicles
Trolley jacks and axle stands		Suitable	Not suitable
Vehicle hoist		Suitable	Not suitable
Inspection pit with suitable ventilation	Width <sup>1</sup>	0.8–1.0 m	0.8–1.0 m
	Depth <sup>1</sup>	1.3 m	1.3 m
	Length <sup>1</sup>	4 m	Side entry: 10 m End entry: 15 m

<sup>1</sup> Where these dimensions cannot be met, smaller dimensions may be considered for approval on a case by case basis. Similarly, where larger vehicles are likely to be inspected, the dimension requirements may need to be increased to allow for a comfortable and safe inspection.

#### Other requirements and considerations

- a) The under-body inspection facility must be centrally aligned within the inspection area.
- b) The pit length is measured at the base of the pit and does not include any steps that may be located at the ends.
- c) There must be sufficient and suitable lighting provided for the under-body inspection.

#### 5.1.4 Equipment

The inspecting organisation must hold the following equipment in good condition and working order:

- a) Industrial quality hand-held inspection lamp suitable for use with alternative fuel ('gas-proof lamp').
- b) Gas leak detection equipment (minimum is equipment for soap bubble test; electronic gas detection equipment is recommended).
- c) Workshop tools for the inspection of alternative fuel (spanners, screwdrivers etc).

Access to the following alternative fuel standards is recommended:

- a) NZS 5422: 1987: Code of practice for the use of LPG and CNG fuels in internal combustion engines: Part 1: LPG fuel and Part 2: CNG fuel
- b) AS/NZS 1425: 2003 LP Gas Fuel Systems for Vehicle Engines
- c) AS/NZS 2739: 2003 Natural Gas (CNG) Fuel Systems for Vehicle Engines
- d) AS/NZS 1425: 2007 LP Gas fuel systems for vehicle engines.

#### 5.1.5 Compliance with statutory requirements

It is the inspecting organisation's responsibility to ensure that the inspection premises and equipment comply with:

- a) Occupational Safety and Health requirements, and
- b) any other relevant Acts, regulations, and local bylaws.

### **6.1 Vehicle inspectors**

Applications for appointment must be sponsored by an employing inspecting organisation.

The candidate must:

- a) be qualified as an automotive technician with NZ Trade Certificate or National Certificate in Motor Industry (Automotive Engineering), and
- b) have an Automotive Trade Extension Certificate in Motor Vehicles Conversion – Petrol to Gas (LPG/CNG)
- c) demonstrate comprehensive knowledge of common alternative fuel systems used in the propulsion of motor vehicles and the requirements in the Vehicle Inspection Requirements Manual: Alternative Fuel System Certification sufficient to inspect and certify a vehicle correctly.
- d) be a fit and proper person (clause 2.6 of the Rule). The criteria considered include:
  - relevant criminal convictions
  - transport related offences
  - relevant warnings, penalties and disciplinary actions imposed
  - relevant complaints
  - the public interest and land transport safety.

Application packs may be obtained from, and applications must be made to:

DVCU Administration

Transport Registry Centre

PO Box 11 777

Palmerston North 4442

Phone 0800 587 287

### **6.2 Inspecting organisations**

Inspecting organisations must:

- a) meet the requirements for inspection premises and equipment, and
- b) be fit and proper (clause 2.6 of the Rule). The criteria considered with any application include:
  - relevant criminal convictions
  - transport related offences
  - relevant warnings, penalties and disciplinary actions imposed
  - relevant complaints
  - the public interest and land transport safety, and
- c) have currently employed a vehicle inspector approved to inspect alternative fuel systems.



**Alternative Fuel Inspection Certificate** means evidence of vehicle inspection relating to the periodic in-service inspection and certification of an alternative fuel system. (Note: This is the alternative fuel inspection label that is affixed to the windscreen.)

**Alternative Fuel System Installation Certificate** means an inspection and certification document relating to the installation of an alternative fuel system (MOT 4069 form).

**Alternative fuel system** means a fuel storage and conducting system that is used to provide liquid petroleum gas, compressed natural gas, or any other pressurised liquid or gaseous fuel (other than petrol or diesel) for the purpose of propulsion of a vehicle.

**Alternative fuel system inspection and certification** means inspection and certification of an alternative fuel system comprising either:

- a) specialist inspection and certification required for the issuing of an Alternative Fuel System Installation Certificate (not covered in this manual), or
- b) in-service inspection and certification required for the issuing of an Alternative Fuel Inspection Certificate.

**Applicable requirement** means any requirement specified or incorporated in an Act, regulation, code or rule that applies to the design, construction, condition, equipment, modification, repair or maintenance of a specific vehicle. All applicable requirements for in-service inspection and certification are contained in this manual.

**Authorised agency, in relation to any alternative fuel system or component of such a system**, means a person or firm who is authorised as an authorised agency by the Director under Regulation 90G of the Traffic Regulations 1976.

**Authorised person, in relation to any alternative fuel system or component of such a system**, means a person who is declared by Regulation 90E of the Traffic Regulations 1976 to be an authorised person, or any person authorised by the Director under Regulation 90F of the Traffic Regulations 1976 as an authorised person.

**Certificate of fitness (CoF)** means evidence of vehicle inspection issued to vehicles listed under 3.3.1 of the Introduction section of the VIRM: In-service Certification.

**Certify** means, in relation to a vehicle, or specific aspects of a vehicle, to make a record of determination that confirms that the vehicle inspector or inspecting organisation has determined that the vehicle or specific aspects of the vehicle complies with the requirements in Land Transport Rule: Vehicle standards Compliance 2002.

**Charged, in relation to any alternative fuel system**, means containing sufficient CNG or LPG to cause a properly fitted and operative fuel gauge for that system to register other than empty. CNG means compressed natural gas.

**Compliance plate** means an attachment to a vehicle in the form of a plate that confirms compliance of the vehicle's alternative fuel system with AS/NZS 2739 or AS/NZS 1425.

**Corrosion damage** is where the metal has been eaten away, which is evident by pitting. The outward signs of such corrosion damage is typically displayed by the lifting or bubbling of paint. In extreme cases, the area affected by the corrosion damage will fall out and leave a hole.

**Deregistered** means that a vehicle's New Zealand registration has been cancelled.

**Determination** means a record, in paper or electronic form, that a vehicle or specific aspect of a vehicle complies or does not comply with requirements in this rule.

**Director** means the Director of Land Transport.

**Evidence of vehicle inspection** in relation to a vehicle means any certificate, label, or document issued as evidence of the completion of the periodic vehicle inspection requirements in respect of that vehicle.

**Forklift** means a motor vehicle (not fitted with self-laying tracks) designed principally for lifting, carrying and stacking goods by means of one or more tines, platens or clamps.

**Inspecting organisation** means a person or organisation appointed by the Director who is responsible for inspection and certification outcomes.

**Inspection and certification** means the performance of two or more of the following, for the purposes of determining compliance with applicable requirements:

- a) examining vehicles
- b) determining whether or not a vehicle or specific aspect of a vehicle complies with applicable requirements
- c) issuing evidence of vehicle inspection, a conditional permit or a certificate of loading
- d) recording and making available information about vehicles (including their systems, components, devices, fittings and equipment).

**Inspection and certification document** means a document required, produced or issued in the inspection and certification process, including a plate, a label, an electronic record, and a checksheet.

**Inspection and certification outcome** in relation to a vehicle means:

- a) production of a record of determination as appropriate to the inspection and certification activity, or
- b) provision of other records and information about the vehicle to the Director or other persons, or
- c) production of evidence of vehicle inspection, conditional permits or certificates of loading.

**LPG** means liquefied petroleum gas.

**Manufacturer's operating limits** means:

- a) in relation to a vehicle, the allowance provided by the vehicle manufacturer in terms of performance capability and dimensions, relative to deterioration, malfunction or damage beyond which the safe performance of the vehicle, as defined by the vehicle manufacturer, is compromised, and
- b) in relation to a system, component or item of equipment, incorporated in or attached to a vehicle, the allowance provided by the system, component or equipment manufacturer in terms of performance capability and dimensions, relative to the deterioration, malfunction or damage, beyond which the safe performance of the system, component or item of equipment (and consequently the vehicle) is compromised.

**Motor vehicle** means a vehicle drawn or propelled by mechanical power, and includes a trailer, but does not include:

- a) a vehicle running on rails
- b) an invalid carriage
- c) a trailer (other than a trailer designed solely for the carriage of goods) that is designed and used exclusively as part of the armament of the New Zealand Defence Force
- d) a trailer running on one wheel and designed exclusively as a speed measuring device or for testing the wear of vehicle tyres
- e) a vehicle designed for amusement purposes and used exclusively within a place of recreation, amusement, or entertainment to which the public does not have access with motor vehicles
- f) a pedestrian-controlled machine.

**OE** means original equipment fitted at the time of manufacture of the vehicle, or a part supplied by the vehicle manufacturer.

**Operate** in relation to a vehicle means to drive or use the vehicle on a road, or to cause or permit the vehicle to be on a road or to be driven on a road, whether or not the person is present with the vehicle.

**Operation in service** in relation to a vehicle means to be operated on the road in New Zealand after having been registered in compliance with registration requirements.

**Repair** means to restore a damaged or worn vehicle, its structure, systems, components or equipment, and includes the replacement of damaged or worn structures, systems, components or equipment with equivalent undamaged or new structures, systems, components or equipment.

**Rule** means Land Transport Rule: Vehicle Standards Compliance 2002: Rule 3500/1.

**Safe tolerance** means the tolerance within which the safe performance of the vehicle, its structure, systems, components or equipment is not compromised, having regard to any manufacturer's operating limits.

**VCU** means the Vehicle Certification Unit of Land Transport New Zealand.

**Vehicle identification number (VIN)** means a group of letters and numbers consisting of 17 characters that:

- a) is affixed to a vehicle in accordance with the relevant standard prescribed under the Traffic Regulations 1976, and
- b) is capable of being decoded to provide identifying information about that vehicle.

**Vehicle inspector** means an individual appointed by the Director to carry out inspection and certification activities in accordance with requirements and conditions imposed by the Director.

**Warrant of fitness (WoF)** means evidence of vehicle inspection issued to a vehicle listed under 3.3.2 of the Introduction section of the VIRM: In-service Certification.

# Introduction

# 8 Sample certification documents

Garage  
copy  
(front)

**Alternative Fuel System Installation Certificate**

This is to certify that the motor vehicle described below has been fitted with an alternative fuel system of the make and type described. The installation complies in full with Land Transport Rule: Vehicle Equipment 2004 and the relevant conditions imposed by the NZ Transport Agency under Land Transport Rule: Vehicle Standards Compliance 2002.

*Please keep this certificate in a safe place*

Vehicle registration no. **XXXXXX**

Make of vehicle: \_\_\_\_\_ Model: \_\_\_\_\_

Fuel system make: \_\_\_\_\_

Model: \_\_\_\_\_ Type of fuel: \_\_\_\_\_

Fuel cylinder make: \_\_\_\_\_ Specification or Standard: \_\_\_\_\_

Number of fuel cylinders fitted: \_\_\_\_\_ Serial nos. \_\_\_\_\_

Total cylinder capacity over all cylinders (litres-CNG only): \_\_\_\_\_ Cylinder test expiry date(s): \_\_\_\_\_

Installed by (print) \_\_\_\_\_  
Signature: \_\_\_\_\_ Date: \_\_\_\_\_

Certified by (print) \_\_\_\_\_ Auth. person reg. no. \_\_\_\_\_  
Signature: \_\_\_\_\_ Date: \_\_\_\_\_

Agency name (print) \_\_\_\_\_ Authorised agent no. \_\_\_\_\_  
Address (print): \_\_\_\_\_  
Signature: \_\_\_\_\_ Date certificate issued: \_\_\_\_\_

Note: Both A and B are to be completed even if the installation and certification are carried out by the same authorised person.

New Zealand Government **Garage Copy** AF4069 11/08

Garage  
copy  
(back)

Details from previous certificates may be obtained from the original authorised agent.

Notes:

Owner's  
copy  
(front)

**Alternative Fuel System Installation Certificate**

This is to certify that the motor vehicle described below has been fitted with an alternative fuel system of the make and type described. The installation complies in full with Land Transport Rule: Vehicle Equipment 2004 and the relevant conditions imposed by the NZ Transport Agency under Land Transport Rule: Vehicle Standards Compliance 2002.

*Please keep this certificate in a safe place*

Vehicle registration no. **XXXXXX**

Make of vehicle: \_\_\_\_\_ Model: \_\_\_\_\_

Fuel system make: \_\_\_\_\_

Model: \_\_\_\_\_ Type of fuel: \_\_\_\_\_

Fuel cylinder make: \_\_\_\_\_ Specification or Standard: \_\_\_\_\_

Number of fuel cylinders fitted: \_\_\_\_\_ Serial nos. \_\_\_\_\_

Total cylinder capacity over all cylinders (litres-CNG only): \_\_\_\_\_ Cylinder test expiry date(s): \_\_\_\_\_

Installed by (print) \_\_\_\_\_  
Signature: \_\_\_\_\_ Date: \_\_\_\_\_

Certified by (print) \_\_\_\_\_ Auth. person reg. no. \_\_\_\_\_  
Signature: \_\_\_\_\_ Date: \_\_\_\_\_

Agency name (print) \_\_\_\_\_ Authorised agent no. \_\_\_\_\_  
Address (print): \_\_\_\_\_  
Signature: \_\_\_\_\_ Date certificate issued: \_\_\_\_\_

Note: Both A and B are to be completed even if the installation and certification are carried out by the same authorised person.

New Zealand Government **Owner's Copy** AF4069 11/08

Owner's  
copy  
(back)

**Notes for holder of this certificate**

This certificate shall be kept in a good and legible condition preferably in the vehicle.

The certificate must be produced at each annual inspection or whenever necessary.

When any cylinder forming part of the alternative fuel system fitted to this vehicle is replaced - or any new cylinder is added - a new Installation Certificate must be issued.

Details from previous certificates may be obtained from the original authorised agent.

Notes:

Figure 3a. Alternative Fuel System Installation Certificate (MOT 4069) – current

# Introduction      8 Sample certification documents cont.

Garage  
copy  
(front)

<b>transportsafety</b>		<b>Alternative Fuel System Installation Certificate</b>	
<p>This is to certify that the motor vehicle described below has been fitted with an alternative fuel system of the make and type described. The installation complies in full with the Traffic Regulations 1976 and the relevant conditions imposed by the Director of Land Transport Safety under those regulations.  <i>Please keep this certificate in a safe place together with all other such certificates issued.</i></p>			
Vehicle Registration No.		209601	
Make of Vehicle	Model		
Fuel System Make			
Model	Type of Fuel		
Fuel Cylinder Make	Specification or Standard		
Number of fuel cylinders fitted	Serial Nos.		
Total cylinder capacity over all cylinders (litres-CNG only)		Cylinder tests expiry date(s)	
<input checked="" type="checkbox"/> Installed by (print)		Auth. Person Reg. No.	
Signature	Date		
<input checked="" type="checkbox"/> Certified by (print)		Auth. Person Reg. No.	
Signature	Date		
<input checked="" type="checkbox"/> Agency Name (print)		Authorised Agent No.	
Address (print)			
Signature	Date Certificate Issued		
<small>Note: Both A and B are to be completed even if the installation and certification are carried out by the same authorised person.</small>			
<b>Garage Copy</b>			

Garage  
copy  
(back)

<p>Details from previous certificates may be obtained from the original authorised agent.</p> <p><b>Notes:</b></p> <p>.....</p> <p>.....</p> <p>.....</p> <p>.....</p> <p>.....</p> <p>.....</p> <p>.....</p>
---

Owner's  
copy  
(front)

<b>transportsafety</b>		<b>Alternative Fuel System Installation Certificate</b>	
<p>This is to certify that the motor vehicle described below has been fitted with an alternative fuel system of the make and type described. The installation complies in full with the Traffic Regulations 1976 and the relevant conditions imposed by the Director of Land Transport Safety under those regulations.  <i>Please keep this certificate in a safe place</i></p>			
Vehicle Registration No.		209601	
Make of Vehicle	Model		
Fuel System Make			
Model	Type of Fuel		
Fuel Cylinder Make	Specification or Standard		
Number of fuel cylinders fitted	Serial Nos.		
Total cylinder capacity over all cylinders (litres-CNG only)		Cylinder tests expiry date(s)	
<input type="checkbox"/> A Installed by (print)		Auth. Person Reg. No.	
Signature	Date		
<input type="checkbox"/> B Certified by (print)		Auth. Person Reg. No.	
Signature	Date		
<input type="checkbox"/> C Agency Name (print)		Authorised Agent No.	
Address (print)			
Signature	Date Certificate Issued		
<small>Note: Both A and B are to be completed even if the installation and certification are carried out by the same authorised person.</small>			
<b>Owner's Copy</b> MOT4069			

Owner's  
copy  
(back)

<p><b>Notes for holder of this certificate</b></p> <p>This certificate shall be kept in a good and legible condition preferably in the vehicle.              The certificate must be produced at each annual inspection or whenever necessary.              When any cylinder forming part of the alternative fuel system fitted to this vehicle is replaced - or any new cylinder is added - a new Installation Certificate must be issued.              Details from previous certificates may be obtained from the original authorised agent.</p> <p><b>Notes:</b></p> <p>.....</p> <p>.....</p> <p>.....</p> <p>.....</p> <p>.....</p> <p>.....</p> <p>.....</p>
--

**Figure 3b. Alternative Fuel System Installation Certificate (MOT 4069) – printed until November 2008**

**LIQUEFIED PETROLEUM GAS COMPLIANCE PLATE**

The autogas installation to which this notice is affixed complies with the requirements of Australian/New Zealand Standard AS/NZS 1425.

INSTALLATION DATE.....STATE .....

COMPLIANCE NO. ....

INSTALLED BY:

    NAME .....LIC/AUTHORIZATION NO. ....

WORKSHOP NO. ....(REP. NO.)

VIN NO. ....

CONTAINER SERIAL NO. ....

CONTAINER TEST STATION STAMP DATE .....

Figure 4. LPG compliance plate

**CNG COMPLIANCE PLATE**

The CNG installation to which this notice is affixed complies with the requirements of AS/NZS 2739

INSTALLATION DATE . . . . . STATE INSTALLED . . . . .

CERTIFICATE OF COMPLIANCE NO. . . . .

INSTALLED BY:

NAME . . . . . LIC. NO. . . . .

VEHICLE IDENTIFICATION NO. . . . .

Figure 5. CNG compliance plate

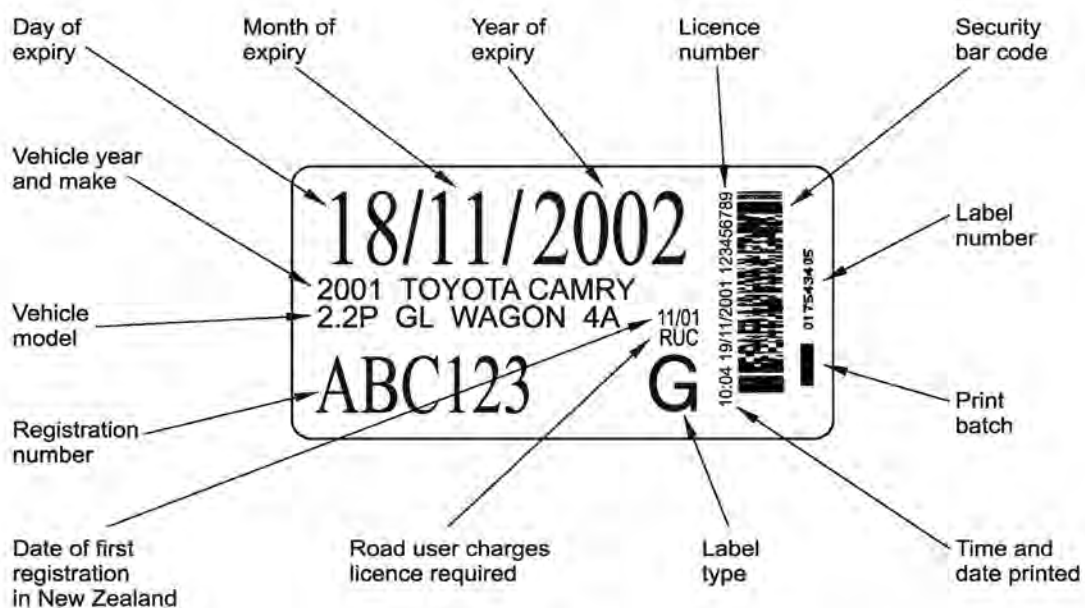

Figure 6. Vehicle licence label



**Vehicle Inspection Requirements Manual: Alternative Fuel System Certification**

Date: \_\_\_\_\_

Inspection Manual topic: \_\_\_\_\_

Page number needing improvement: \_\_\_\_\_

Details of suggested improvement: \_\_\_\_\_

---

---

---

---

---

---

---

Writer's contact details (in case we need to contact you for further clarification)

Name: \_\_\_\_\_

Company name: \_\_\_\_\_

Postal address: \_\_\_\_\_

---

---

Phone/fax/email: \_\_\_\_\_

---

Please send the completed form to:

Technical Publisher

Driver and Vehicle Certification Unit

NZ Transport Agency

PO Box 5084

Wellington 6145

Fax: 04 894 5011

---



Summary of legislation	Reasons for rejection
<p><b>Applicable legislation</b></p> <ul style="list-style-type: none"> <li>• Land Transport Rule: Vehicle Standards Compliance 2002, subclause 7.3(2)</li> <li>• Traffic Regulations 1976: Reg 90K and Reg 90L</li> <li>• AS/NZS 1425: 2003, section 6.9</li> </ul> <p><b>Mandatory equipment</b></p> <ol style="list-style-type: none"> <li>1. A vehicle that is fitted with an alternative fuel system in working order must have an Alternative Fuel System Installation Certificate before it is issued with an Alternative Fuel Inspection Certificate.</li> <li>2. The alternative fuel system must match the details on the installation certificate and fully comply with the requirements of TR76 and any approval granted under them.</li> <li>3. A vehicle fitted with an LPG alternative fuel system to NZS 5422: 1987 must have an identification plate installed preferably in the engine compartment displaying 'LPG', the container identification numbers and the date of installation.</li> <li>4. A vehicle fitted with an LPG alternative fuel system to AS/NZS 1425: 2003 Part 1 must have an LP gas compliance plate (one for each container) securely attached to the body work in the engine bay in a clearly visible location.</li> </ol>	<p><b>Mandatory equipment</b></p> <ol style="list-style-type: none"> <li>1. A vehicle fitted with an alternative fuel system in working order does not have an Alternative Fuel System Installation Certificate (<b>Notes 1 and 2</b>) (<b>Figure 1-1-1</b>).</li> <li>2. A vehicle fitted with an LPG alternative fuel system to NZS 5422: 1987 Part 1 does not have an identification plate installed displaying:             <ol style="list-style-type: none"> <li>a) the text 'LPG', or</li> <li>b) the identification number of each container, or</li> <li>c) the date of installation.</li> </ol> </li> <li>3. A vehicle fitted with an LPG alternative fuel system to AS/NZS 1425: 2003 does not have an LP gas compliance plate (one for each container) securely attached to the body work in the engine bay in a clearly visible location (<b>Figure 1-1-2</b>).</li> <li>4. The installation certificate or identification plate or compliance plate:             <ol style="list-style-type: none"> <li>a) does not match the vehicle, or</li> <li>b) does not match the alternative fuel system fitted to the vehicle, or</li> <li>c) is not legible, or</li> <li>d) is not valid.</li> </ol> </li> </ol>

**Note 1** Installation certificate means an installation certificate issued under regulation 90H of the Traffic Regulations 1976. It must be in the prescribed form (**Figure 1-1-1**), and the issuer must give the owner's copy to the owner and file the garage copy in a secure place.

**Note 2** Where no original installation certificate can be produced, a new installation certificate must be issued.

Garage copy (front)

**transportsafety** Alternative Fuel System Installation Certificate

This is to certify that the motor vehicle described below has been fitted with an alternative fuel system of the make and type described. The installation complies in full with the Traffic Regulations 1976 and the relevant conditions imposed by the Director of Land Transport Safety under those regulations.  
 This copy must be filed in a secure place together with all other such certificates issued.  
 Vehicle Registration No. **209601**

Make of Vehicle \_\_\_\_\_ Model \_\_\_\_\_

Fuel System Make \_\_\_\_\_

Model \_\_\_\_\_ Type of Fuel \_\_\_\_\_

Fuel Cylinder Make \_\_\_\_\_ Specification or Standard \_\_\_\_\_

Number of fuel cylinders fitted \_\_\_\_\_ Serial Nos. \_\_\_\_\_

Total cylinder capacity over all cylinders (litres-CNG only) \_\_\_\_\_ Cylinder tests expiry date(s) \_\_\_\_\_

Installed by (print) \_\_\_\_\_ Auth. Person Reg. No. \_\_\_\_\_  
 Signature \_\_\_\_\_ Date \_\_\_\_\_

Certified by (print) \_\_\_\_\_ Auth. Person Reg. No. \_\_\_\_\_  
 Signature \_\_\_\_\_ Date \_\_\_\_\_

Agency Name (print) \_\_\_\_\_ Authorised Agent No. \_\_\_\_\_  
 Address (print) \_\_\_\_\_  
 Signature \_\_\_\_\_ Date Certificate Issued \_\_\_\_\_

*Note: Both A and B are to be completed even if the installation and certification are carried out by the same authorised person.*

Garage Copy

Garage copy (back)

Details from previous certificates may be obtained from the original authorised agent.

Notes:

Owner's copy (front)

**transportsafety** Alternative Fuel System Installation Certificate

This is to certify that the motor vehicle described below has been fitted with an alternative fuel system of the make and type described. The installation complies in full with the Traffic Regulations 1976 and the relevant conditions imposed by the Director of Land Transport Safety under those regulations.  
 Please keep this certificate in a safe place.  
 Vehicle Registration No. **209601**

Make of Vehicle \_\_\_\_\_ Model \_\_\_\_\_

Fuel System Make \_\_\_\_\_

Model \_\_\_\_\_ Type of Fuel \_\_\_\_\_

Fuel Cylinder Make \_\_\_\_\_ Specification or Standard \_\_\_\_\_

Number of fuel cylinders fitted \_\_\_\_\_ Serial Nos. \_\_\_\_\_

Total cylinder capacity over all cylinders (litres-CNG only) \_\_\_\_\_ Cylinder tests expiry date(s) \_\_\_\_\_

Installed by (print) \_\_\_\_\_ Auth. Person Reg. No. \_\_\_\_\_  
 Signature \_\_\_\_\_ Date \_\_\_\_\_

Certified by (print) \_\_\_\_\_ Auth. Person Reg. No. \_\_\_\_\_  
 Signature \_\_\_\_\_ Date \_\_\_\_\_

Agency Name (print) \_\_\_\_\_ Authorised Agent No. \_\_\_\_\_  
 Address (print) \_\_\_\_\_  
 Signature \_\_\_\_\_ Date Certificate Issued \_\_\_\_\_

*Note: Both A and B are to be completed even if the installation and certification are carried out by the same authorised person.*

Owner's Copy MOT4069

Owner's copy (back)

**Notes for holder of this certificate**

This certificate shall be kept in a good and legible condition preferably in the vehicle.  
 The certificate must be produced at each annual inspection or whenever necessary.  
 When any cylinder forming part of the alternative fuel system fitted to this vehicle is replaced - or any new cylinder is added - a new Installation Certificate must be issued.  
 Details from previous certificates may be obtained from the original authorised agent.

Notes:

Figure 1-1-1. Alternative Fuel System Installation Certificate (MOT 4069)

**LIQUEFIED PETROLEUM GAS COMPLIANCE PLATE**

The autogas installation to which this notice is affixed complies with the requirements of Australian/New Zealand Standard AS/NZS 1425.

INSTALLATION DATE..... STATE .....

COMPLIANCE NO. ....

INSTALLED BY:

NAME .....LIC/AUTHORIZATION NO. ....

WORKSHOP NO. ....(REP. NO.)

VIN NO. ....

CONTAINER SERIAL NO. ....

CONTAINER TEST STATION STAMP DATE .....

Figure 1-1-2. LPG compliance plate details

Summary of legislation	Reasons for rejection
<p><b>Applicable legislation</b></p> <ul style="list-style-type: none"> <li>Traffic Regulations 1976: Reg 90Q</li> <li>NZS 5422: 1987 Part 1, section 7.1</li> <li>AS/NZS 1425: 2003, section 7.4</li> </ul> <p><b>Mandatory equipment</b></p> <ol style="list-style-type: none"> <li>A vehicle must be fitted with identification labels as shown in <b>Figure 1-2-1</b> positioned in a clearly visible location as close as practicable to the front and rear registration plates.</li> </ol>	<p><b>Mandatory equipment</b></p> <ol style="list-style-type: none"> <li>A vehicle is not fitted with identification labels as shown in <b>Figure 1-2-1</b> positioned in a clearly visible location as close as practical to the front and rear registration plates.</li> </ol> <p><b>Condition</b></p> <ol style="list-style-type: none"> <li>An identification label: <ol style="list-style-type: none"> <li>is illegible, or</li> <li>has unauthorised alterations.</li> </ol> </li> </ol>

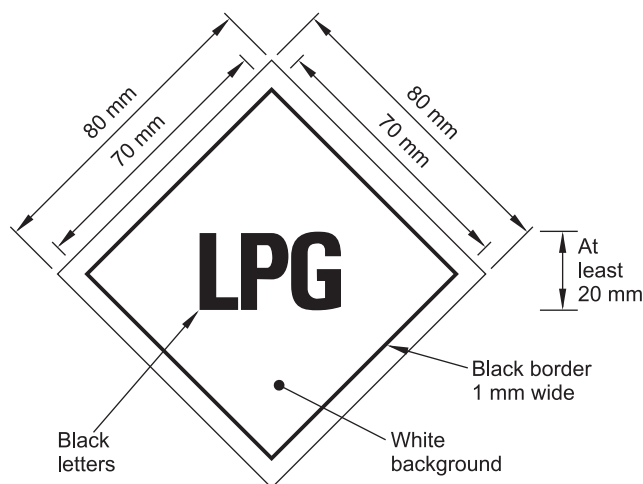

**Figure 1-2-1. LPG vehicle identification label**

**Note 1** AS/NZS 1425: 2003 specifies a red diamond for Australia. Vehicles fitted with red diamonds may retain these, but must also be fitted with the white diamonds specified above.

### Summary of legislation

#### Applicable legislation

- AS/NZS 1425: 2003, section 6.9.2(b)

#### Condition

- The container must be stamped with the test date and the identification mark of the cylinder testing station.
- The date stamp on a container must be within ten years of the next alternative fuels inspection.
- A container must not be damaged by impact to the extent described in **Table 1-3-1**.

### Reason for rejection

#### Condition

- The container's test date and cylinder testing station identification mark:
  - are missing, or
  - are not legible, or
  - have been altered, or
  - have not been stamped on the container.
- There are more than ten years between the test date stamped on the container and the date of the next alternative fuels inspection.
- A container has been damaged by fire.
- A container has visible corrosion damage (**Note 1**).
- A container has been damaged by impact and exceeds any damage limit in **Table 1-3-1**.
- A container has visible cracks or signs of metal fatigue.

**Table 1-3-1. Container impact damage limits**

Dent	Sharp impression or crease	Cuts or gouge	Bulge
Depth exceeds 10% of mean diameter of dent	Length exceeds 75 mm	Length exceeds 75 mm	Container circumference varies by more than 1%
Dent on a weld exceeds 6.5 mm in depth	Penetrates visibly into wall material	Penetrates visibly into wall material	

**Note 1** Container means a pressure vessel, cylinder or tank for the storage of LP Gas to be used as fuel for the internal combustion engine.

**Note 2** Corrosion damage is where the metal has been eaten away, which is evident by pitting. The outward signs of such corrosion damage are typically displayed by the lifting or bubbling of paint. In extreme cases, the area affected by the corrosion damage will fall out and leave a hole.

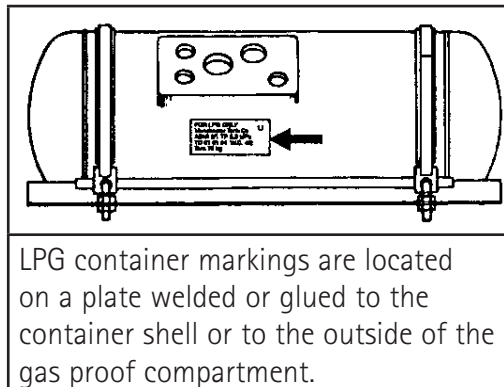

**Figure 1-3-1. Container markings**

**Summary of legislation****Applicable legislation**

- AS/NZS1425: 2003, section 6.9.2 (e)

**Condition**

1. A container attachment must not have any of the following conditions such that the security of the attachment is at risk:
  - a) rust, corrosion, abrasion or impact damage
  - b) loose nuts, worn or stretched bolts
  - c) loose bands, wear under bands, incompatible band materials
  - d) incorrect orientation of the container.

**Reason for rejection****Condition**

1. The security of the container attachment has been affected or weakened by:
  - a) rust, corrosion, abrasion or impact damage, or
  - b) loose nuts, worn or stretched bolts, or
  - c) loose bands, wear under bands, incompatible band materials, or
  - d) incorrect orientation of the container, or
  - e) visible cracks or signs of metal fatigue.

## Summary of legislation

### Applicable legislation

- Traffic Regulations 1976: Reg 90K(2)(c)
- AS/NZS1425: 2003, section 3.3

### Mandatory equipment

1. An alternative fuel system with a fixed LPG container must be fitted with the components in column 1 of **Table 1-5-1**.
2. The components in **Table 1-5-1** must be mounted directly on the container without any intermediate pipe or fitting, except for those components associated with a remote filling arrangement.

#### Filler connection

3. The filler connection must have:
  - a) a cap that is captive (where practicable), and
  - b) a sealing washer.
4. The filler connection must be recessed below the body panel or be provided with equivalent protection.
5. If an automatic fuel limiting valve is fitted, a notice must be displayed at the filler connection that reads AFL FITTED.

#### Safety valve system

6. A safety valve:
  - a) must be mounted with no valve between it and the container, and
  - b) must not discharge towards or into a passenger compartment, and
  - c) must not discharge directly on:
    - i. the container, or
    - ii. bystanders, or
    - iii. adjacent vehicles.
  - d) must release gas:
    - i. into a compartment or sub-compartment, or
    - ii. vertically upward, with a tolerance of 45° from the vertical, at a remote discharge point.

### Permitted equipment

7. An LPG alternative fuel system may be fitted with the components permitted in **Table 1-5-1**.
8. An automatic fuel shut-off device, if fitted, must be mounted directly on the container, with a fuel filter between it and the container that is capable

## Reasons for rejection

### Mandatory equipment

1. A component listed in **Table 1-5-1** is missing.
2. An item in **Table 1-5-1** is not mounted directly on the container without any intermediate pipe or fitting, except for those components associated with a remote filling arrangement or an automatic fuel shut-off device fitted to containers manufactured prior to January 1994.

#### Filler connection

3. The filler connection cap is:
  - a) missing, or
  - b) not held captive by a strap or similar device where it would be practicable to do so.
4. The sealing washer is missing.
5. The filler connection is not protected by the body panel or by something equivalent.
6. An automatic fuel limiting valve is fitted and a notice is not displayed at the filler connection that reads AFL FITTED.

#### Safety valve system

7. A safety valve:
  - a) is mounted with another valve between it and the container, or
  - b) discharges towards or into a passenger compartment, or
  - c) discharges directly on:
    - i. the container, or
    - ii. bystanders, or
    - iii. adjacent vehicles, or
  - d) does not discharge either:
    - i. into a compartment or sub-compartment, or
    - ii. vertically upward with a tolerance of 45° from the vertical.

### Permitted equipment

8. An automatic fuel shut-off device is fitted and:
  - a) it is not mounted directly on the container, or
  - b) there is no fuel filter between it and the container.

Summary of legislation
<p>of removing from the fuel all particulate matter that could cause malfunction of the automatic fuel shut-off device or pressure regulator.</p> <p><b>Condition</b></p> <p>9. Container fittings must be in safe working condition.</p> <p><b>Filler connection</b></p> <p>10. The coupling must be in sound condition and free of foreign matter.</p> <p>11. The sealing washer must be in satisfactory condition.</p> <p>12. The filler connection housing must be soundly attached to the vehicle.</p> <p>13. The remote fill line must not be damaged or twisted.</p>

Reasons for rejection
<p><b>Condition</b></p> <p>9. A fitting is not in safe working condition (<b>Note 1</b>).</p> <p>10. The wording on a label in <b>Table 1-5-1</b> is not clearly legible.</p> <p><b>Filler connection</b></p> <p>11. The coupling is damaged or contains foreign matter.</p> <p>12. The condition of the sealing washer is unsatisfactory.</p> <p>13. The filler connection housing is not soundly attached to the vehicle.</p> <p>14. The remote fill line is damaged or twisted.</p> <p><b>Hydrostatic relief valve</b></p> <p>15. A hydrostatic relief valve is damaged, blocked or has been tampered with.</p>

**Table 1-5-1. Mandatory and permitted LPG alternative fuel system components (Note 1)**

Mandatory LPG alternative fuel system components	Permitted LPG alternative fuel system components
Filler connection Filler cap Filler non-return valve system Automatic fill limiting valve <sup>1</sup> Service valve (fittings to NZS 5422: 1987: Part 1 must have a permanent label with the words SERVICE VALVE or similar) Excess flow valve Safety valve Contents gauge with a label adjacent to the bleed valves with the words STOP FILLING WHEN LIQUID APPEARS	Automatic fuel shut-off device, mounted directly on the container, with a fuel filter between it and the container that is capable of removing from the fuel all particulate matter that could cause malfunction of the automatic fuel shut-off device or pressure regulator. Hydrostatic relief valve Any component that forms part of the originally certified LPG alternative fuel system.

<sup>1</sup>Older systems may have a manual bleed valve instead of an automatic fill limiting valve.

**Note 1 Definitions:**

**Automatic fill limiter** means a provision in the filling system which automatically terminates filling when a predetermined liquid level in the container has been reached.

**Automatic fuel shut-off device** means a provision for automatically shutting off the fuel supply unless certain essential conditions exist.

**Contents gauge** means a gauge which gives a visual indication of the liquid content of the container. This may be read at the container or remotely.

**Excess-flow valve** means a valve normally in the open position which closes automatically when flow in a specified direction exceeds a predetermined limit.

**Hydrostatic relief valve** means a valve whose purpose is to relieve and prevent overpressure in any fuel service line carrying LP Gas liquid.

**Safety valve** means a valve which automatically discharges vapour to atmosphere so as to prevent a predetermined pressure being exceeded. It is activated by the static pressure upstream of the valve.

**Service valve** means a manually operated shut-off valve fitted on the container which can open or shut-off the LP Gas supply to the engine for maintenance servicing or emergency requirements.

## Summary of legislation

### Applicable legislation

- Traffic Regulations 1976: Reg 90K(2)(c)
- AS/NZS1425: 2003, section 6.9.2(j)
- AS/NZS1425: 2003, section 3.17

### Mandatory equipment

1. Where a container is located within the body shell (**Note 1**) of a vehicle, either
  - a) the whole of the container and its attached components and fittings must be enclosed in a compartment that is vented to the atmosphere, or
  - b) the valves, fittings, and pipe connections associated with or attached to the container must be enclosed in a sub-compartment attached to the container and vented to the atmosphere.
2. The service valve and, where appropriate, the fixed liquid level indicator bleed valve, must be readily accessible and operable without the use of tools.
3. Fittings to AS/NZS 1425: 2003: A gastight hatch must be provided with a marking that reads **WARNING: KEEP CLOSED AND GASTIGHT EXCEPT WHEN THE SERVICE VALVE MUST BE OPERATED.**

### Condition

4. The compartment structure, joints, conduit connections and pipe bulkhead seals must not be deteriorated, damaged, kinked or punctured so that gas may leak or gas flow through a vent could be constricted.
5. The compartment or sub-compartment must be gastight.

## Reasons for rejection

### Mandatory equipment

1. A container is located within the body shell of a vehicle and no compartment or sub-compartment is fitted (**Note 1**).
2. The compartment or sub-compartment is not vented to the atmosphere.
3. The service valve is not readily accessible to authorised people or cannot be operated without the use of tools or cannot be operated fully.
4. A fixed liquid level indicator bleed valve is fitted but is not readily accessible when filling or cannot be operated without the use of tools.
5. Fittings to AS/NZS 1425:2003: A gastight hatch is not provided with a marking that reads **WARNING: KEEP CLOSED AND GASTIGHT EXCEPT WHEN THE SERVICE VALVE MUST BE OPERATED.**

### Condition

6. Any of the compartment structure, joints, conduit connections or pipe bulkhead seals are deteriorated, damaged, kinked or punctured so that gas may leak or gas flow through a vent could be restricted.
7. The compartment or sub-compartment is inspected and found not to be gastight (**Note 2**).

**Note 1** **Compartment** means a structure which encloses the whole of the container and its fittings, whose purpose is to collect any gas leakage which might occur, so that it can be discharged to open air. A car boot is not an acceptable compartment under 1 above. **Sub-compartment** means a structure attached to the container, which encloses the container fittings, and whose purpose is to collect any gas leakage which might occur, so that it can be discharged to open air.

**Note 2** AS/NZS 1425: 2003, section 6.8.2 describes a standard gastight test.

## Summary of legislation

### Applicable legislation

- Traffic Regulations 1976: Reg 90K(2)(c)
- AS/NZS1425: 2003, section 6.9.2(h)
- AS/NZS1425: 2003, section 5.9

### Mandatory equipment

1. Where alternative fuels are available the vehicle must be fitted with a fuel selector to prevent the supply of more than one fuel at a time (**Note 1**).
2. Fittings to AS/NZS 1425: 2003: The dual-fuel selector, if visible to the driver in the normal driving position, must be marked to indicate the selected fuel.

### Condition

3. The selector must be in working condition and operable by hand without the use of tools.

### Performance

4. The fuel selector must allow the supply of the alternative fuels one at a time.

## Reasons for rejection

### Mandatory equipment

1. Where LPG is not the only fuel supply, no dual-fuel selector is fitted.
2. Fittings to AS/NZS 1425:2003: The dual-fuel selector is visible to the driver in the normal driving position and is not marked to indicate the selected fuel.

### Condition

3. The dual-fuel selector is:
  - a) not in working condition, or
  - b) requires the use of tools to be operated.
4. The dual-fuel marking are illegible.

### Performance

5. The fuel selector does not allow the supply of the indicated fuel.
6. The fuel selector allows the supply of more than one fuel at a time in positions where this is not intended (**Note 1**).

**Note 1** Some systems are designed to allow petrol and LPG to flow when switching from LPG to petrol.

Summary of legislation	Reasons for rejection
<p><b>Applicable legislation</b></p> <ul style="list-style-type: none"> <li>Traffic Regulations 1976: Reg 90K(2)(c)</li> <li>NZS 5422: Part 1: 1987 2.3</li> <li>AS/NZS1425: 2003, section 6.9.2(o)</li> <li>AS/NZS1425: 2003, section 3.19</li> </ul> <p><b>Mandatory equipment</b></p> <ol style="list-style-type: none"> <li>An installation to NZS 5422: 1987: Part 1 must meet the requirements in the left-hand column of <b>Table 1-8-1</b>.</li> <li>An installation to AS/NZS 1425: 2003 must meet the requirements in the right-hand column or, if this is not practicable, the requirements in the left-hand column of <b>Table 1-8-1</b>.</li> </ol>	<p><b>Mandatory equipment</b></p> <ol style="list-style-type: none"> <li>An installation to NZS 5422: 1987: Part 1 does not meet all the requirements in the left-hand column of <b>Table 1-8-1</b>.</li> <li>An installation to AS/NZS 1425: 2003 does not meet all the requirements in either:             <ol style="list-style-type: none"> <li>the right-hand column of <b>Table 1-8-1</b>, or</li> <li>the left-hand column of <b>Table 1-8-1</b> if the requirements in the right-hand column are not practicable.</li> </ol> </li> </ol>

Table 1-8-1. Location and ground clearance requirements

Requirements from NZS 5422: 1987: Part 1	Requirements from AS/NZS 1425: 2003
<ol style="list-style-type: none"> <li>Containers, fittings and pipework must be mounted inside the perimeter of the vehicle.</li> <li>Container valves on externally mounted containers must be positioned no less than 200 mm from the vehicle extremities.</li> <li>A container must not be fitted:             <ol style="list-style-type: none"> <li>on the roof or above a passenger compartment</li> <li>forward of the rear of the driver's seat in its rearmost position without specific approval</li> <li>in a position beneath the vehicle that decreases the effective ground clearance.</li> </ol> </li> <li>A container located between or behind the axles must be within the zone limit shown in <b>Figure 1-8-1</b>.</li> </ol>	<ol style="list-style-type: none"> <li>The whole of a fuel container, compartment and sub-compartment must lie within the ground clearance zone limits indicated by <b>Table 1-8-2</b> and <b>Figure 1-8-2</b> and <b>Figure 1-8-3</b>.</li> <li>A container must not be mounted outside the body contour to the front or sides of the vehicle.</li> <li>A container must not be mounted outside the body contour to the rear or top of the vehicle without specific approval.</li> <li>A container installed inside a vehicle must not be mounted forward of the rear of the driver's seat in its rearmost position.</li> </ol>

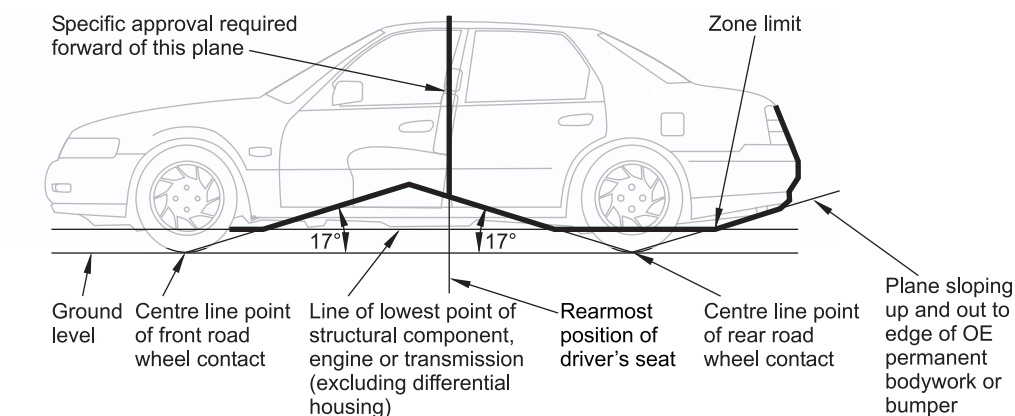
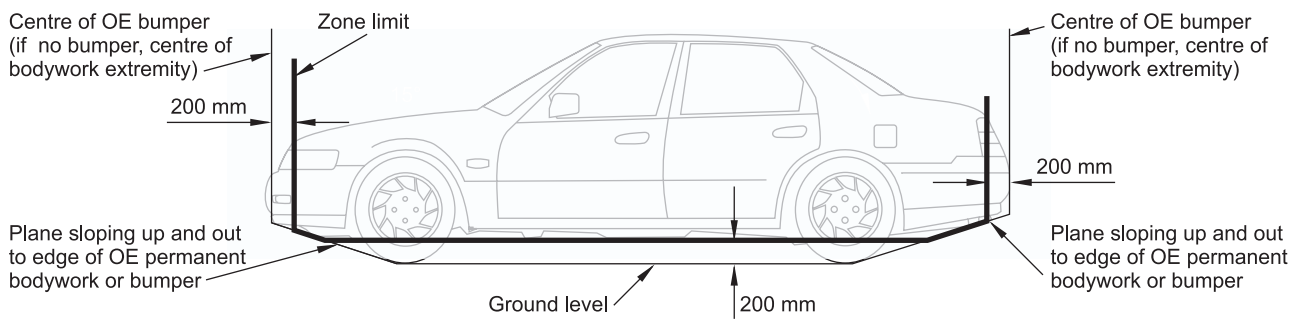

Figure 1-8-1. Zone limit for container location (requirements from NZS 5422: 1987: Part 1)

**Table 1–8–2. Ground clearance zone limits (requirements from AS/NZS 1425: 2003)**

Vehicle mass <sup>1</sup>	Chassis ground clearance at rear of vehicle	Figure that shows ground clearance zone limits
Less than 4500 kg	600 mm or less	Figure 1–8–2
Less than 4500 kg	More than 600 mm	Figure 1–8–3
4500 kg or more	600 mm or less	Figure 1–8–2
4500 kg or more	More than 600 mm	Figure 1–8–3

<sup>1</sup> Unladen mass with fuel, coolant and oil containers full.



**Figure 1–8–2. Ground clearance zone limits for a small vehicle (requirements from AS/NZS 1425:2003)**

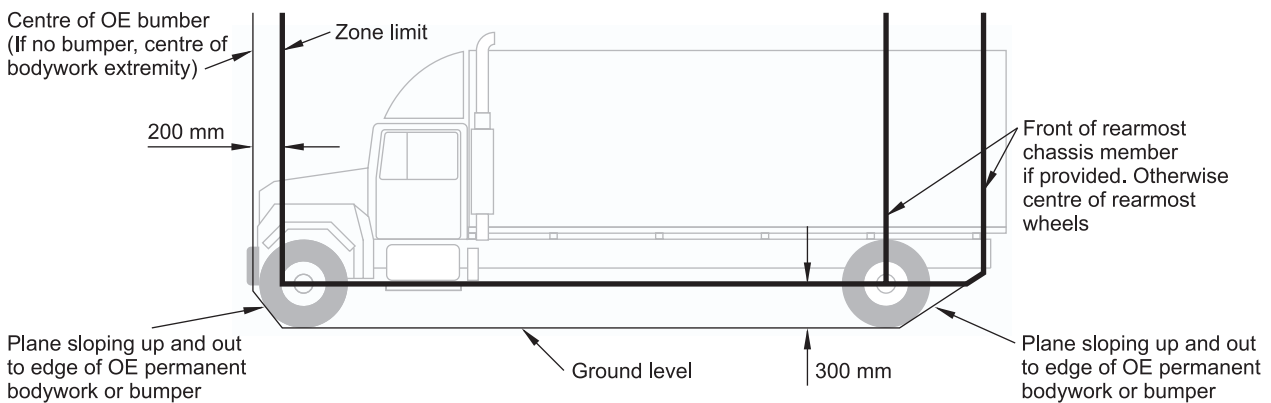

**Figure 1–8–3. Ground clearance zone limits for a large vehicle (requirements from AS/NZS 1425:2003)**

## Summary of legislation

### Applicable legislation

- Traffic Regulations 1976: Reg 90K(2)(c)
- AS/NZS1425: 2003, section 4

### Mandatory equipment

1. A fuel service line must not enter an enclosed driver, passenger or luggage compartment.
2. A fuel service line in a drive shaft tunnel must not be closer than 40 mm from the drive shaft under all operating conditions.
3. The underside of a fuel service line must be within 15 mm of the intersection of the drive shaft tunnel and the floor pan.
4. A fuel service line below the body shell must be protected from impact or abrasion.
5. A fuel service line in a wheel arch must be
  - a) protected from thrown-up objects, and
  - b) positioned so the tyre cannot rub on the fuel line.
6. Rigid piping subject to corrosion must be protected throughout its exposed length.
7. Rigid piping must be secured to the chassis frame or body with cushioned clips not more than 600 mm apart.
8. Hoses must be secured to the chassis frame or body with clips not more than 600 mm apart.
9. A pipe or hose must be protected with a grommet where it passes through a body panel.
10. A pipe, hose, component or fitting subject to container pressure, and not fully protected by a radiation shield at least 15 mm away, must not be within 150 mm of a hot object at a temperature above the normal water jacket temperature.
11. A pipe, hose, component or fitting subject to container pressure, and fully protected by a radiation shield at least 15 mm away, must not be within 40 mm of a hot object at a temperature above the normal water jacket temperature (**Figure 1-9-1**).

### Condition

12. An alternative fuel system in working order must be in a safe working condition.

## Reasons for rejection

### Mandatory equipment

1. A fuel service line enters an enclosed driver, passenger or luggage compartment (**Note 1**).
2. A fuel service line in a drive shaft tunnel is within 40 mm of the drive shaft under some operating conditions.
3. The underside of a fuel service line in a drive shaft tunnel is more than 15 mm from the intersection of the drive shaft tunnel and the floor pan.
4. Required fuel line protection is missing.
5. A required clip or grommet is missing.
6. A pipe, hose, component or fitting subject to container pressure that is not fully protected by a radiation shield at least 15 mm away is within 150 mm of a hot object at a temperature above the normal water jacket temperature.
7. A pipe, hose, component or fitting subject to container pressure that is fully protected by a radiation shield at least 15 mm away is within 40 mm of a hot object at a temperature above the normal water jacket temperature (**Figure 1-9-1**).

### Condition

8. A fuel line:
  - a) shows signs of corrosion damage (**Note 2**) such as pitting, or
  - b) is bulging, or
  - c) is insecure, or
  - d) is twisted, or
  - e) is kinked, or
  - f) shows damage, such as cuts, crimps, or abrasions that expose the wire.

**Note 1** Fuel service line means piping, other than the fill line, used for the conveyance of LP Gas liquid at a pressure exceeding 450 kPa.

**Note 2** Corrosion damage is where the metal has been eaten away, which is evident by pitting. The outward signs of such corrosion damage are typically displayed by the lifting or bubbling of paint. In extreme cases, the area affected by the corrosion damage will fall out and leave a hole.

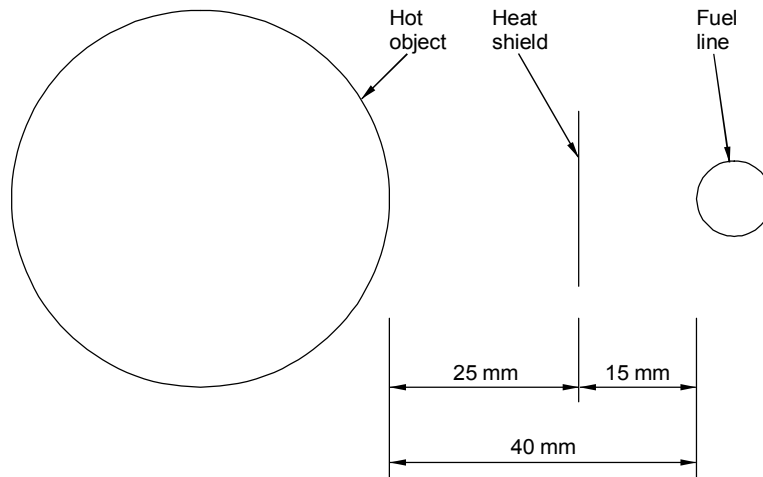

**Figure 1-9-1. Minimum fuel line distance to hot object with heat shield**

Summary of legislation	Reasons for rejection
<p><b>Applicable legislation</b></p> <ul style="list-style-type: none"><li>• Traffic Regulations 1976: Reg 90K(2)(c)</li><li>• AS/NZS1425: 2003, section 6.9.2(a)</li></ul> <p><b>Condition and performance</b></p> <ol style="list-style-type: none"><li>1. Pipe and component connections must be gastight.</li><li>2. All manual valves must be gas tight in both open and closed positions.</li></ol>	<p><b>Condition and performance</b></p> <ol style="list-style-type: none"><li>1. With LP Gas in the container and fuel lines full of LP Gas liquid, and all pipe connections tested for leaks, a leak is indicated.</li><li>2. With LP Gas in the container and fuel lines full of LP Gas liquid, and all valves tested for leaks in both open and closed positions, a leak is indicated.</li></ol>

**Note 1** Guidance on acceptable leak detection methods are given in AS/NZS 1425: 2003 Appendix C.

**Summary of legislation****Applicable legislation**

- Land Transport Rule: Vehicle Standards Compliance 2002
- AS/NZS 2739: 2003, section 6.9

**Mandatory equipment**

1. A vehicle that is fitted with an alternative fuel system in working order must have an Alternative Fuel System Installation Certificate before it is issued with an Alternative Fuel Inspection Certificate.
2. The alternative fuel system must match the installation certificate and fully comply with the requirements of TR76 and any approval granted under them.
3. A CNG fuel system installed in a vehicle must comply with an applicable CNG fuel system standard as specified in **Table 1-1-1 (Note 3)**.
4. A vehicle fitted with a CNG alternative fuel system to NZS: 5422: 1987: Part 2 must have an identification plate installed near the refuelling connection clearly visible to the refueller displaying 'CNG', the cylinder identification numbers, the date of installation, the water capacity of the total installation, the date of the last retest and the vehicle registration number.
5. A vehicle fitted with a CNG alternative fuel system to AS/NZS 2739 must have a CNG compliance plate securely attached to the body work in the engine bay in a clearly visible location.

**Reason for rejection****Mandatory equipment**

1. A vehicle fitted with an alternative fuel system in working order does not have an Alternative Fuel System Installation Certificate (**Notes 1 and 2**) (**Figure 2-1-1**).
2. A CNG fuel system fitted to a vehicle does not comply with an applicable standard specified in **Table 1-1-1 (Note 3)**.
3. A vehicle fitted with a CNG alternative fuel system to NZS: 5422: 1987 does not have an identification plate displaying:
  - a) the text 'CNG', or
  - b) the identification number of each cylinder, or
  - c) the date of installation, or
  - d) the water capacity of the total installation, or
  - e) the date of the last retest, or
  - f) the vehicle registration number.
4. A vehicle fitted with a CNG alternative fuel system to AS/NZS 2739 does not have a CNG compliance plate securely attached to the body work in the engine bay in a clearly visible location.
5. The installation certificate or identification plate or compliance plate (**Figure 2-1-2**):
  - a) does not match the vehicle, or
  - b) does not match the alternative fuel system fitted to the vehicle, or
  - c) is not legible, or
  - d) is not valid.

**Table 1-1-1. LPG standards requirements**

Date the LPG System was fitted	
Before 1 July 2005	On or after 1 July 2005
Must comply with: <ul style="list-style-type: none"> <li>• NZS 5442: 1987, or</li> <li>• AS/NZS 2739: 2003</li> </ul>	Must comply with: <ul style="list-style-type: none"> <li>• AS/NZS 2739: 2003</li> </ul>

**Note 1** Installation certificates are prescribed by the NZ Transport Agency (including its predecessors). The most recent certificate is provided in the Introduction section page 25.

**Note 2** Where no original installation certificate can be produced, a new installation certificate must be issued.

# CNG 2-1 Alternative fuel system installation certification cont.

Garage copy  
(front)

<span style="font-weight: bold; font-size: small;">Alternative Fuel System Installation Certificate</span>	
<small>This is to certify that the motor vehicle described below has been fitted with an alternative fuel system of the make and type described. The installation complies in full with the Traffic Regulations 1976 and the relevant conditions imposed by the Director of Land Transport Safety under those regulations.</small>	
<small><i>This copy must be filed in a secure place together with all other such certificates issued.</i></small>	
Vehicle Registration No.	209601
Make of Vehicle <input style="width: 60%;" type="text"/>	Model <input style="width: 20%;" type="text"/>
Fuel System Make <input style="width: 100%;" type="text"/>	
Model <input style="width: 50%;" type="text"/>	Type of Fuel <input style="width: 50%;" type="text"/>
Fuel Cylinder Make <input style="width: 50%;" type="text"/>	Specification or Standard <input style="width: 50%;" type="text"/>
Number of fuel cylinders fitted <input style="width: 10%;" type="text"/>	Serial Nos. <input style="width: 80%;" type="text"/>
Total cylinder capacity over all cylinders (litres-CNG only) <input style="width: 40%;" type="text"/>	Cylinder tests expiry date(s) <input style="width: 60%;" type="text"/>
<b>A</b> Installed by (print) <input style="width: 70%;" type="text"/> Auth. Person Reg. No. <input style="width: 30%;" type="text"/>	
Signature <input style="width: 80%;" type="text"/>	Date <input style="width: 20%;" type="text"/>
<b>B</b> Certified by (print) <input style="width: 70%;" type="text"/> Auth. Person Reg. No. <input style="width: 30%;" type="text"/>	
Signature <input style="width: 80%;" type="text"/>	Date <input style="width: 20%;" type="text"/>
<b>C</b> Agency Name (print) <input style="width: 70%;" type="text"/> Authorised Agent No. <input style="width: 30%;" type="text"/>	
Address (print) <input style="width: 100%;" type="text"/>	
Signature <input style="width: 80%;" type="text"/>	Date Certificate Issued <input style="width: 20%;" type="text"/>
<small><i>Note: Both A and B are to be completed even if the installation and certification are carried out by the same authorised person.</i></small>	
<b>Garage Copy</b>	

Details from previous certificates may be obtained from the original authorised agent.

**Notes:**

Garage copy  
(back)

Owner's copy  
(front)

<span style="font-weight: bold; font-size: small;">Alternative Fuel System Installation Certificate</span>	
<small>This is to certify that the motor vehicle described below has been fitted with an alternative fuel system of the make and type described. The installation complies in full with the Traffic Regulations 1976 and the relevant conditions imposed by the Director of Land Transport Safety under those regulations.</small>	
<small><i>Please keep this certificate in a safe place</i></small>	
Vehicle Registration No.	209601
Make of Vehicle <input style="width: 60%;" type="text"/>	Model <input style="width: 20%;" type="text"/>
Fuel System Make <input style="width: 100%;" type="text"/>	
Model <input style="width: 50%;" type="text"/>	Type of Fuel <input style="width: 50%;" type="text"/>
Fuel Cylinder Make <input style="width: 50%;" type="text"/>	Specification or Standard <input style="width: 50%;" type="text"/>
Number of fuel cylinders fitted <input style="width: 10%;" type="text"/>	Serial Nos. <input style="width: 80%;" type="text"/>
Total cylinder capacity over all cylinders (litres-CNG only) <input style="width: 40%;" type="text"/>	Cylinder tests expiry date(s) <input style="width: 60%;" type="text"/>
<b>A</b> Installed by (print) <input style="width: 70%;" type="text"/> Auth. Person Reg. No. <input style="width: 30%;" type="text"/>	
Signature <input style="width: 80%;" type="text"/>	Date <input style="width: 20%;" type="text"/>
<b>B</b> Certified by (print) <input style="width: 70%;" type="text"/> Auth. Person Reg. No. <input style="width: 30%;" type="text"/>	
Signature <input style="width: 80%;" type="text"/>	Date <input style="width: 20%;" type="text"/>
<b>C</b> Agency Name (print) <input style="width: 70%;" type="text"/> Authorised Agent No. <input style="width: 30%;" type="text"/>	
Address (print) <input style="width: 100%;" type="text"/>	
Signature <input style="width: 80%;" type="text"/>	Date Certificate Issued <input style="width: 20%;" type="text"/>
<small><i>Note: Both A and B are to be completed even if the installation and certification are carried out by the same authorised person.</i></small>	
<b>Owner's Copy</b>	

**Notes for holder of this certificate**

This certificate shall be kept in a good and legible condition preferably in the vehicle.

The certificate must be produced at each annual inspection or whenever necessary.

When any cylinder forming part of the alternative fuel system fitted to this vehicle is replaced - or any new cylinder is added - a new Installation Certificate must be issued.

Details from previous certificates may be obtained from the original authorised agent.

**Notes:**

Owner's copy  
(back)

**Figure 1-1-1. Alternative Fuel System Installation Certificate (MOT 4069)**

**CNG COMPLIANCE PLATE**

The CNG installation to which this notice is affixed complies with the requirements of AS/NZS 2739

INSTALLATION DATE . . . . . STATE INSTALLED . . . . .

CERTIFICATE OF COMPLIANCE NO. . . . .

INSTALLED BY:

NAME . . . . . LIC. NO. . . . .

VEHICLE IDENTIFICATION NO. . . . .

Figure 2-1-2. CNG compliance plate

Summary of legislation	Reasons for rejection
<p><b>Applicable legislation</b></p> <ul style="list-style-type: none"> <li>NZS 5422: Part 1: 1987 section 7.1</li> <li>AS/NZS 2739: 2003 section 6.9 and 7.4</li> <li>Traffic Regulations 1976, Reg 90Q</li> </ul> <p><b>Mandatory equipment</b></p> <ol style="list-style-type: none"> <li>An identification label as shown in <b>Figure 2-2-1</b> must be affixed as close as practicable to each of the vehicle's registration plates.</li> </ol>	<p><b>Mandatory equipment</b></p> <ol style="list-style-type: none"> <li>An identification label as shown in <b>Figure 2-2-1</b> is not affixed as close as practicable to each of the vehicle's registration plates.</li> </ol> <p><b>Condition</b></p> <ol style="list-style-type: none"> <li>A required plate label or notice: <ol style="list-style-type: none"> <li>is illegible, or</li> <li>has unauthorised alterations.</li> </ol> </li> </ol>

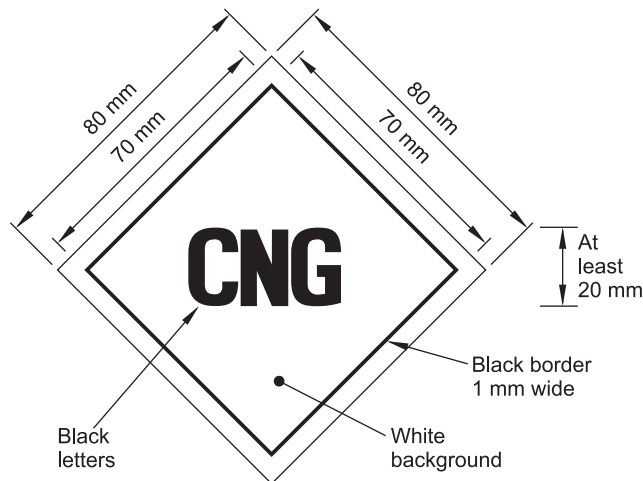

**Figure 2-2-1. CNG vehicle identification label**

**Note 1** AS/NZS 2739: 2003 specifies a red circle for Australia. Vehicles fitted with red circles may retain these, but must also be fitted with the white diamonds specified above.

### Summary of legislation

#### Applicable legislation

- AS/NZS 2739: 2003, section 6.9

#### Condition

- The cylinder must be stamped with the test date and the identification mark of the cylinder testing station.
- The date stamp on a cylinder must be within five years of the next alternative fuels inspection.
- A cylinder must not show evidence of impact damage, corrosion, or heating by fire.

### Reason for rejection

#### Condition

- The cylinder's test date and cylinder testing station identification mark:
  - are missing, or
  - are not legible, or
  - have been altered, or
  - have not been stamped on the container.
- There are more than five years between the test date stamped on a cylinder and the date of the next alternative fuels inspection.
- A cylinder shows evidence of impact damage, corrosion, or heating by fire.

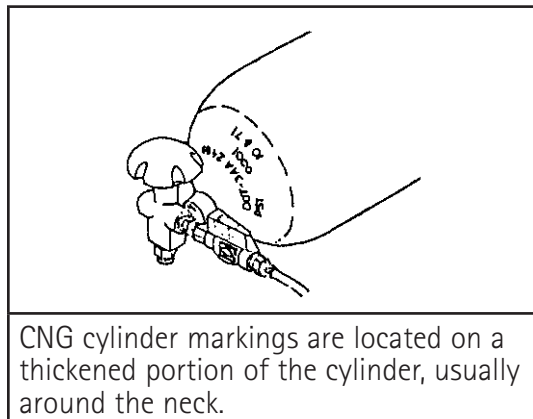

**Figure 2-3-1. Cylinder markings**

Note 1 Cylinder means a pressure vessel, or gas cylinder for the storage of CNG to be used as fuel for an engine.

**Summary of legislation****Applicable legislation**

- AS/NZS 2739: 2003, section 6.9

**Condition**

1. A cylinder attachment must not have any of the following conditions such that the security of the attachment is at risk:
  - a) rust, corrosion, abrasion or impact damage
  - b) loose nuts, worn or stretched bolts
  - c) loose bands, wear under bands, incompatible band materials
  - d) cracks or metal fatigue.

**Reason for rejection****Condition**

1. The security of the container attachment has been affected or weakened by:
  - a) rust, corrosion, abrasion or impact damage, or
  - b) loose nuts, worn or stretched bolts, or
  - c) loose bands, wear under bands, incompatible band materials, or
  - d) cracks or metal fatigue.

Summary of legislation
<p><b>Applicable legislation</b></p> <ul style="list-style-type: none"> <li>Traffic Regulations 1976: Reg 90K and 90L</li> <li>AS/NZS 2739:2003, section 6.9</li> </ul> <p><b>Mandatory equipment</b></p> <ol style="list-style-type: none"> <li>The fuel supply system must include the items in <b>Table 2-5-1</b>.</li> <li>Installations to NS/NZS 2739: 2003 must have a refuelling information plate which includes the next cylinder retest date. (This may be combined with the compliance plate on vehicles with the refuelling connection in the engine bay.)</li> <li>Installations to NZS 5422: 1987: Part 2 must have a permanent label near the service isolation valve with the wording CNG SERVICE SHUT-OFF VALVE or similar and a clear indication of the CLOSED and OPEN positions.</li> </ol> <p><b>Condition</b></p> <ol style="list-style-type: none"> <li>All fuel system components must be in safe working condition.</li> <li>The refuelling connection must:             <ol style="list-style-type: none"> <li>be free of foreign matter, and</li> <li>have a dust plug or cap that is:                 <ol style="list-style-type: none"> <li>captive, where practicable, and</li> <li>securely attached.</li> </ol> </li> </ol> </li> </ol> <p><b>Performance</b></p> <ol style="list-style-type: none"> <li>All manual valves must operate without the necessity for tools.</li> <li>An automatic fuel shut-off device must operate when the engine is not running.</li> <li>The refuelling interlock device must cut the power to the starter motor when the refuelling nozzle is engaged.</li> </ol>

## Reasons for rejection

### Mandatory equipment

- An item listed in **Table 2-5-1** is missing.
- An installation to AS/NZS 2739: 2003 does not have a refuelling information plate which includes the next cylinder retest date or does not have this information on the compliance plate in the engine bay.
- An installation to NZS 5422: 1987: Part 2 does not have a permanent label near the service isolation valve with the wording CNG SERVICE SHUT-OFF VALVE or similar and a clear indication of the CLOSED and OPEN positions.

### Condition

- A component is not in good working condition.
- The refuelling connection is dirty.
- The refuelling connection dust plug or cap is:
  - missing, or
  - not securely attached, or
  - not held captive by a strap or similar device where it would be practicable to do so.

### Performance

- A manual valve cannot be operated without the use of tools.
- The automatic fuel shut-off device allows CNG to flow to the engine when it is not running (**Note 2**).
- The starter motor can be operated when the refuelling interlock device micro-switch is operated (**Note 3**).

**Table 2-5-1. Mandatory equipment for a CNG fuel supply system (Note 1)**

Fuel cylinder(s) Cylinder valve(s) Refuelling connection	Refuelling non-return valve Service isolation valve Fuel filter	Fuel shut-off device (lock off) Fuel flow regulator Refuelling interlock device
--	---	---

#### Note 1 Definitions:

**Non-return valve** means a valve which permits fuel flow in only one direction.

**Automatic fuel shut-off device** means a provision for shutting off the fuel supply unless certain essential conditions exist.

**Refuelling interlock device** means a system used to control the delivery pressure of gaseous fuel to the engine.

**Note 2** Automatic fuel shut-off devices can normally be heard operating. They can be made to operate in a number of ways:

- a) Electrically operated valves may be operated by cutting the power supply to them. Turning the fuel selector knob to a non-CNG fuel (petrol or diesel) will cut the power supply.
- b) Valves will open when the ignition is turned on, and will then close if the engine is not cranked.
- c) Vacuum-operated valves can be activated by disconnecting the appropriate hose.

**Note 3** The interlock device micro-switch can usually be operated with a finger.

Summary of legislation	Reasons for rejection
<p><b>Applicable legislation</b></p> <ul style="list-style-type: none"> <li>• Traffic Regulations 1976: Reg 90K and 90L</li> <li>• AS/NZS 2739: 2003, section 6.9</li> </ul> <p><b>Mandatory equipment</b></p> <ol style="list-style-type: none"> <li>1. Where a cylinder is located within the body shell of the vehicle, either               <ol style="list-style-type: none"> <li>a) the whole of the cylinder and its attached components and fittings must be enclosed in a compartment that is vented to the atmosphere, or</li> <li>b) the valves, fittings, and pipe connections associated with or attached to the container must be enclosed in a sub-compartment attached to the container and vented to the atmosphere.</li> </ol> </li> </ol> <p><b>Condition</b></p> <ol style="list-style-type: none"> <li>2. The compartment structure, joints, conduit connections and pipe bulkhead seals must not be deteriorated, damaged, kinked or punctured so that gas may leak or gas flow through a vent could be constricted.</li> <li>3. The compartment or sub-compartment must be gastight.</li> </ol>	<p><b>Mandatory equipment</b></p> <ol style="list-style-type: none"> <li>1. A cylinder is located within the body shell of the vehicle and no compartment or sub-compartment is fitted that (<b>Notes 1 and 2</b>):               <ol style="list-style-type: none"> <li>a) encloses the valves, fittings and pipe connections associated with the cylinder, and</li> <li>b) is vented to the atmosphere.</li> </ol> </li> </ol> <p><b>Condition</b></p> <ol style="list-style-type: none"> <li>2. The compartment structure, joints, conduit connections or pipe bulkhead seals are deteriorated, damaged, kinked or punctured so that gas may leak or gas flow through a vent could be constricted.</li> <li>3. The compartment or sub-compartment is not gastight (<b>Note 3</b>).</li> </ol>

**Note 1** **Cylinder compartment** means a structure of rigid or pliable material which encloses the whole of the cylinder and its fittings, whose purpose is to collect any gas leakage which might occur, so that it can be discharged to open air. A car boot is not an acceptable compartment.

**Note 2** **Cylinder sub-compartment** means a structure of rigid or pliable material which encloses the cylinder fittings, whose purpose is to collect any gas leakage which might occur, so that it can be discharged to open air.

**Note 3** Note: AS/NZS 2739: 2003, section 6.8.2 describes a standard gastight test.

Summary of legislation
<p><b>Applicable legislation</b></p> <ul style="list-style-type: none"> <li>Traffic Regulations 1976: Reg 90K and 90L</li> <li>AS/NZS 2739: 2003 section 6.9 and 3.16</li> <li>NZS 5422: Part 2: 1987, section 2.3</li> </ul> <p><b>Mandatory equipment</b></p> <ol style="list-style-type: none"> <li>Installations to NZS 5422: 1987: Part 2 must meet the requirements in the left-hand column of <b>Table 2-7-1</b>.</li> <li>Installations to AS/NZS 2739: 2003 must meet the requirements in the right-hand column of <b>Table 2-7-1</b>, or if this is not practicable, the requirements in the left-hand column.</li> </ol>

Reasons for rejection
<p><b>Mandatory equipment</b></p> <ol style="list-style-type: none"> <li>An installation to NZS 5422: 1987: Part 2 does not meet all the requirements in the left-hand column of <b>Table 2-7-1</b>.</li> <li>An installation to AS/NZS 2739: 2003 does not meet all the requirements in either:             <ol style="list-style-type: none"> <li>the right-hand column of <b>Table 2-7-1</b>, or</li> <li>the left-hand column of <b>Table 2-7-1</b> if the requirements in the right-hand column are not practicable.</li> </ol> </li> </ol>

Table 2-7-1. Location and ground clearance requirements

Requirements from NZS 5422: 1987: Part 2	Requirements from AS/NZS 2739: 2003
<ol style="list-style-type: none"> <li>Cylinders, fittings and pipework must be mounted inside the perimeter of the vehicle.</li> <li>Cylinder valves on externally mounted containers must be positioned no less than 200 mm from the vehicle extremities.</li> <li>A cylinder must not be fitted:             <ol style="list-style-type: none"> <li>on the roof or above a passenger compartment</li> <li>forward of the rear of the driver's seat in its rearmost position without specific approval</li> <li>in a position beneath the vehicle that decreases the effective ground clearance.</li> </ol> </li> <li>A cylinder located between or behind the axles must be within the zone limit shown in <b>Figure 2-7-1</b>.</li> </ol>	<ol style="list-style-type: none"> <li>A cylinder must lie within the ground clearance zone limits indicated by <b>Table 2-7-2</b> and <b>Figure 2-7-2</b> and <b>Figure 2-7-3</b>.</li> <li>A cylinder must not be mounted outside the body contour to the front or sides of the vehicle.</li> <li>A cylinder must not be mounted outside the body contour to the rear or top of the vehicle without specific approval.</li> <li>A cylinder must be located such that its fittings are at least 100 mm inside the outer body skin or tray of the vehicle.</li> </ol>

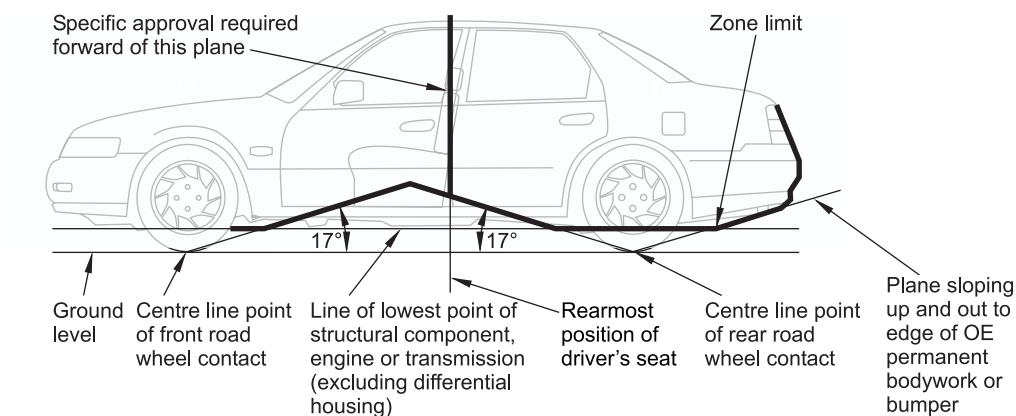
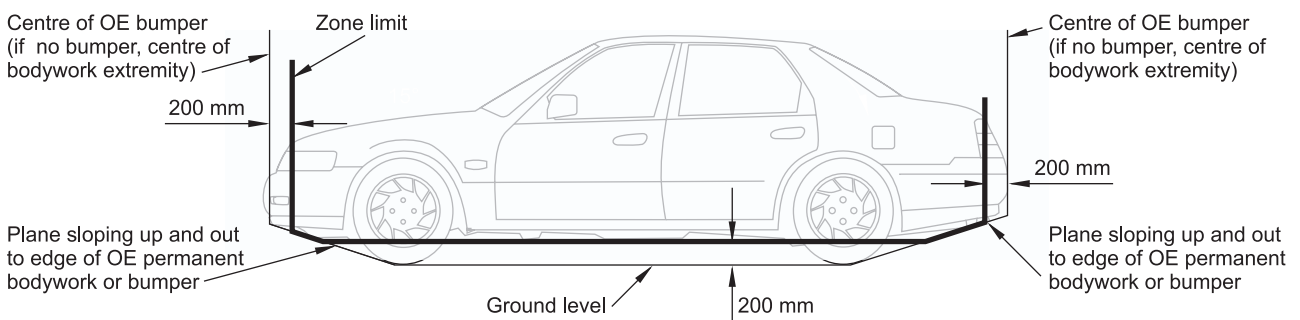

Figure 2-7-1. Zone limit for container location (requirements from NZS 5422: 1987: Part 2)

**Table 2-7-2. Ground clearance zone limits (requirements from AS/NZS 2739: 2003)**

Vehicle mass <sup>1</sup>	Chassis ground clearance at rear of vehicle	Figure that shows ground clearance zone limits
Less than 3500 kg	610 mm or less	Figure 2-7-2
Less than 3500 kg	More than 610 mm	Figure 2-7-3
3500 kg or more	610 mm or less	Figure 2-7-2
3500 kg or more	More than 610 mm	Figure 2-7-3

<sup>1</sup> Unladen mass with fuel, coolant and oil containers full.



**Figure 2-7-2. Ground clearance zone limits for a small vehicle (requirements from AS/NZS 2739: 2003)**

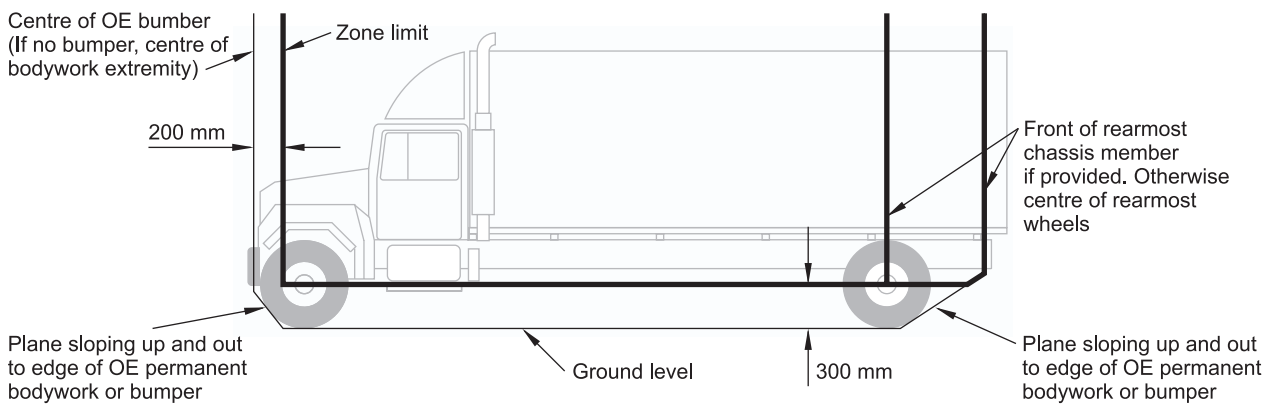

**Figure 2-7-3. Ground clearance zone limits for a large vehicle (requirements from AS/NZS 2739: 2003)**

## Summary of legislation

### Applicable legislation

- Traffic Regulations 1976: Reg 90K and 90L
- AS/NZS 2739: 2003, section 6.9

### Mandatory equipment

1. A fuel service line must not enter an enclosed driver, passenger or luggage compartment.
2. A fuel service line in a drive shaft tunnel must not be closer than 40 mm from the drive shaft under all operating conditions.
3. The underside of a fuel service line must be within 15 mm of the intersection of the drive shaft tunnel and the floor pan.
4. A fuel service line below the body shell must be protected from impact or abrasion.
5. Piping subject to corrosion must be protected throughout its exposed length.
6. Piping must be secured to the chassis frame or body with cushioned clips not more than 600 mm apart.
7. A pipe must be protected with a grommet where it passes through a body panel.
8. A pipe, component or fitting that is not fully protected by a radiation shield at least 15 mm away, must not be within 150 mm of a hot object at a temperature above the normal water jacket temperature.
9. A pipe, component or fitting that is fully protected by a radiation shield at least 15 mm away, must not be within 40 mm of a hot object at a temperature above the normal water jacket temperature (**Figure 2-8-1**).

### Condition

10. An alternative fuel system in working order must be in a safe working condition.

## Reasons for rejection

### Mandatory equipment

1. A fuel service line enters an enclosed driver, passenger or luggage compartment (**Note 1**).
2. A fuel service line in a drive shaft tunnel is within 40 mm of the drive shaft under some operating conditions.
3. The underside of a fuel service line in a drive shaft tunnel is more than 15 mm of the intersection of the drive shaft tunnel and the floor pan.
4. Required fuel line protection is missing.
5. A required clip or grommet is missing.
6. A pipe, component or fitting that is not fully protected by a radiation shield at least 15 mm away is within 150 mm of a hot object at a temperature above the normal water jacket temperature.
7. A pipe, component or fitting that is fully protected by a radiation shield at least 15 mm away is within 40 mm of a hot object at a temperature above the normal water jacket temperature (**Figure 2-8-1**).

### Condition

8. A fuel line:
  - a) shows signs of corrosion damage (**Note 2**) such as pitting, or
  - b) is bulging, or
  - c) is insecure, or
  - d) is twisted, or
  - e) is kinked, or
  - f) shows damage, such as cuts, crimps, or abrasions that expose the wire.

**Note 1** Fuel service line means the fuel line supplying the engine and running from the cylinder(s) to the engine.

**Note 2** Corrosion damage is where the metal has been eaten away, which is evident by pitting. The outward signs of such corrosion damage are typically displayed by the lifting or bubbling of paint. In extreme cases, the area affected by the corrosion damage will fall out and leave a hole.

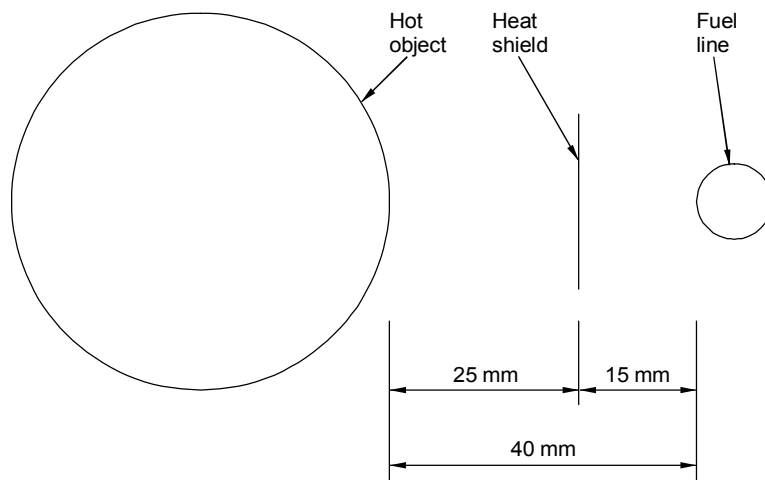

**Figure 2-8-1. Minimum fuel line distance to hot object with heat shield**

Summary of legislation	Reasons for rejection
<p><b>Applicable legislation</b></p> <ul style="list-style-type: none"><li>• Traffic Regulations 1976: Reg 90K and 90L</li><li>• AS/NZS 2739: 2003, section 6.9</li></ul> <p><b>Condition and performance</b></p> <ol style="list-style-type: none"><li>1. Pipe and component connections must be gastight with manual valves in both open and closed positions.</li></ol>	<p><b>Condition and performance</b></p> <ol style="list-style-type: none"><li>1. With maximum pressure in the system and all pipe connections and valves tested for leaks (with valves in both open and closed positions), a leak is indicated <b>(Note 1)</b>.</li></ol>

Note 1 Note: AS/NZS 2739: 2003, Appendix 2 describes leak detection methods.