

# Land Transport Rule: Heavy-vehicle Brakes 2006

Rule 32015

Part 1	Rule requirements.....	3
Section 1	<i>Application</i> .....	3
1.1	Title.....	3
1.2	Scope of the Rule.....	3
1.3	Date when Rule comes into force.....	3
1.4	Application of Rule provisions.....	3
Section 2	<i>General safety requirements and approved vehicle standards</i> .....	3
2.1	Application of requirements.....	3
2.2	General safety requirements.....	3
2.3	Requirements for different types of brake.....	4
2.4	Brake-testing requirements.....	5
2.5	Approved vehicle standards for brakes.....	6
2.6	Approved standards for brake hoses and tubing.....	6
Section 3	<i>Air brake</i> .....	7
3.1	Application of requirements.....	7
3.2	Use of compressed air.....	7
3.3	Compressor capacity.....	7
3.4	Pressure warning devices.....	7
3.5	Pressure gauges.....	7
3.6	Reservoir capacity.....	7
3.7	Priority and protection of air brakes.....	8
[3.8	Minimum safe operating pressure.....	8
Section 4	<i>Hydraulic brake</i> .....	8
Section 5	<i>Auxiliary brakes and controls</i> .....	9
5.1	Retarders and engine brakes.....	9
5.2	Additional brake control devices.....	9
5.3	Devices to keep a vehicle stationary for a limited time.....	9
Section 6	<i>Additional requirements for vehicles not used in combination with other heavy motor vehicles</i> .....	9
Section 7	<i>Additional requirements for vehicles used in combination with other heavy motor vehicles</i> .....	10
7.1	Additional requirements for towing vehicles.....	10
7.2	Additional requirements for trailers.....	10
7.3	Requirements for the connection of the air brake of vehicles in a combination vehicle.....	11
7.4	Requirements for anti-lock brake systems (ABS).....	11
7.5	Specific performance requirements for vehicles manufactured or modified in New Zealand.....	12
Section 8	<i>Modification</i> .....	12
8.1	General requirements for modification.....	12
[8.2	Modifications that do not require specialist certification.....	13
Section 9	<i>Repair and replacement parts</i> .....	13
9.1	Repair.....	13
9.2	Replacement components for vehicle repair.....	13
Section 10	<i>Responsibilities</i> .....	13
10.1	Responsibilities of operators.....	13
10.2	Responsibilities of repairers.....	13
10.3	Responsibilities of modifiers.....	13
10.4	Responsibilities of vehicle inspectors and inspecting organisations.....	13
10.5	Responsibilities of manufacturers and retailers.....	13
10.6	Functions and powers of the [Agency].....	13
Part 2		
Definitions	.....	14
<b>Schedule 1</b>	<b>Interim Performance Specification for Heavy Vehicle Braking</b> .....	19
1.0	Introduction.....	19
2.0	Definitions.....	20
3.0	Scope.....	20
4.0	Equipment requirements.....	20
5.0	Prerequisites for carrying out the braking test.....	21
6.0	Test requirements.....	21
7.0	Conduct of the braking tests.....	21
8.0	Required certification.....	22
9.0	Braking Specification as applied to new vehicles.....	22
<b>Schedule 2</b>	<b>Heavy Vehicle Braking Specification of 6 December 1988</b> .....	22
00.	Introduction.....	22
1.	Scope and limitations.....	22
2.	Equipment requirements.....	23
3.	Pre-conditions for test.....	23
4.	Test requirements.....	23
5.	.....	24
6.	.....	24
7.	.....	24
8.	.....	24
9.	.....	24
10.	.....	24
11.	Future requirements.....	24
<b>Schedule 3</b>	<b>Heavy Vehicle Brake Code, First edition 1991</b> .....	27
<b>Schedule 4</b>	<b>Heavy Vehicle Brake Code, Second edition</b> .....	44
<b>Schedule 5</b>	<b>New Zealand Heavy-vehicle Brake Specification</b> .....	64
1.	Application.....	64

2.	Additional equipment requirements.....	65
3.	Additional system requirements for air brakes.....	65
4.	Additional requirements for powered vehicles not used to tow heavy trailers.....	65
5.	Additional requirements for air-braked powered vehicles that are used to tow heavy trailers other than semi-trailers.....	66
6.	Additional requirements for air-braked full trailers.....	66
7.	Additional requirements for air-braked powered vehicles used to tow semi-trailers.....	66
8.	Additional requirements for air-braked semi-trailers that are used to tow another semi-trailer (first semi-trailer of a B-train).....	66
9.	Additional requirements for air-braked semi-trailers that are not used to tow another semi-trailer.....	67
10.	Requirements for the calculations in this Specification.....	67
11.	Information required to ensure compliance with this Specification.....	68
12.	Information to be provided to the operator.....	68

#### AMENDMENTS

Land Transport Rule: Heavy-vehicle Brakes Amendment 2007

Land Transport Rule: Heavy-vehicle Brakes Amendment 2009

#### Objective of the Rule

**Land Transport Rule: Heavy-vehicle Brakes 2006** is one of a series of Rules that sets safety requirements and standards for systems and components in vehicles operating in New Zealand.

This Rule addresses heavy-vehicle braking, which is one of the most important vehicle safety issues for New Zealand road users. It applies to vehicles with a gross vehicle mass of more than 3500 kilograms. Within this broad category, most heavy vehicles belong within the classification system in *Table A* of the Rule (for example, heavy trucks are Class NB or Class NC). The Rule includes special provisions for vehicles not in *Table A* such as tractors, and for vehicles used in heavy-haulage operations. The Rule does not apply to armoured vehicles that are used exclusively as equipment of the New Zealand Defence Force.

It sets out requirements to ensure that heavy vehicles and heavy-vehicle combinations can brake safely, with balanced brake performance, at any road-legal load condition.

The Rule responds to safety risks identified in the *Parliamentary Report of the Transport Committee on the Inquiry into Truck Crashes 1996*, which found that heavy vehicles were over-represented in New Zealand road trauma statistics. Subsequent analysis of police-reported crashes involving heavy vehicles, for the six-year period from 1997 to 2002, showed that brakes were the single most important vehicle factor in these crashes. The Rule also responds to the results obtained in heavy-vehicle brake surveys in 1998 and 2005. In the context of an average annual social cost of all road crashes (at June 2002 prices) of \$3.1 billion (excluding property damage only crashes) the social costs associated with heavy-vehicle brake problems are of the order of \$70 million a year (about 2.3%).

The Rule contributes to the New Zealand Transport Strategy (NZTS) initiative to assist safety and personal security. It also links with other Rules such as *Land Transport Rule: Heavy Vehicles 2004*; *Land Transport Rule: Setting of Speed Limits 2003* and *Land Transport Rule: Vehicle Dimensions and Mass 2002*.

Specific requirements are contained in the Rule for vehicles modified in a way that may affect their brakes or the performance of their brakes. These requirements are carried over from, and replace, *Policy Statement 3* of the Ministry of Transport dated 26 February 1988. The requirements have been reviewed and there has been some relaxation to provide more flexibility to operators, without compromising safety.

Approved vehicle standards for braking are “incorporated by reference” in the Rule in accordance with section 165 of the *Land Transport Act 1998*, so that they are, effectively, part of the Rule.

Five schedules that set out technical specifications that applied to vehicles that were brake-certified at various times since 1998 are contained in the Rule. The *Interim Performance Specification for Heavy Vehicle Braking* was intended to provide sufficient time for the development of detailed performance requirements for heavy-vehicle brakes, which were then detailed in the *Heavy Vehicle Brake Code* (the **Brake Code**). These specifications applied only to vehicle combinations between 39 and 44 tonnes. The Brake Code was based on the European standard *UN/ECE 13*, and was effective from 1 July 1991 and revised in 1997.

The Rule allows vehicles that were certified for compliance with the Interim Specification or Brake Code to continue to comply with these if they, or their brakes, are unmodified. However, modified vehicles and vehicles certified after a date specified in the Rule will need to be certified according to the requirements set out in *Schedule 5*, the *New Zealand Heavy-vehicle Brake Specification*. The application of these requirements is now extended to all heavy vehicles. The Rule identifies those brake requirements that must be certified for compliance by a Heavy Vehicle Specialist Certifier working under Land Transport Rule: Vehicle Standards Compliance 2002.

The Rule states who is responsible for ensuring compliance with its requirements: operators, repairers, modifiers, vehicle inspectors and inspecting organisations, manufacturers and retailers. This links the Rule to provisions of the Land Transport (Offences and Penalties) Regulations 1999.

Consistency has been ensured with New Zealand's international obligations relating to vehicle safety under the 1958 and 1998 United Nations Agreements, to which this country acceded in 2002. The Rule is also consistent with the Trans-Tasman Mutual Recognition Agreement and incorporates Australian standards. Economic evaluation and regulatory impact analyses have been carried out.

#### Extent of consultation

Consultation on this Rule began in June 2004 when the former Land Transport Safety Authority released the yellow (public consultation) draft. Approximately 500 copies of the yellow draft were sent to industry and other groups and individuals who had registered their interest in the Rule. The availability of the draft Rule was publicised in metropolitan and regional daily newspapers, *Te Maori News* and the *New Zealand Gazette*. The draft Rule was also made available on the Land Transport Safety Authority's internet website. Copies of the draft Rule were sent to libraries and transport organisations overseas.

The Land Transport Safety Authority received 49 submissions on the yellow draft. Issues raised in these submissions were followed up by meeting individually and in groups with the concerned industry representatives. The Land Transport Safety Authority's successor, Land Transport New Zealand, took the submissions into account in redrafting the Rule before it was submitted to Cabinet and to the Minister for Transport Safety for signature.

**Part 1**  
**Rule requirements**

(r 1.1 to r 10.6)

*Section 1*  
*Application*

**1.1 Title**

This Rule is Land Transport Rule: Heavy-vehicle Brakes 2006.

**1.2 Scope of the Rule**

1.2(1) This Rule applies to heavy motor vehicles.

1.2(2) This Rule does not apply to an armoured vehicle that is used exclusively as equipment of the New Zealand Defence Force.

1.2(3) This Rule specifies requirements:

- (a) with which heavy vehicles must comply so as to be operated on a road; and
- (b) that are, for the purposes of Land Transport Rule: Vehicle Standards Compliance 2002, the applicable requirements for braking equipment on heavy motor vehicles.

[1.2(4) The applicable provisions in this Rule, for the purposes of specialist inspection and certification of heavy-vehicle brakes under Land Transport Rule: Vehicle Standards Compliance 2002, are in:

- (a) 2.3(9A); and
- (b) 6.1(2)(a); and
- (c) 7.1(3)(a), 7.1(3)(b), 7.2(3), 7.4(2)(b) and 7.5; and
- (d) 8.1 except as provided in 8.2.]

**1.3 Date when Rule comes into force**

This Rule comes into force on 1 March 2007.

**1.4 Application of Rule provisions**

1.4(1) If there is a conflict between a provision of this Rule and the corresponding provision of a document incorporated by reference in the Rule, the provision of this Rule applies.

1.4(2) If there is a conflict between a provision of this Rule and a provision of Land Transport Rule: Vehicle Standards Compliance 2002, the provision of Land Transport Rule: Vehicle Standards Compliance 2002 applies.

*Section 2*

*General safety requirements and approved vehicle standards*

**2.1 Application of requirements**

2.1(1) A brake fitted to a vehicle must comply:

- (a) with 2.2; and
- (b) as applicable, with other requirements in this Rule.

**2.2 General safety requirements**

2.2(1) A vehicle, other than one in 2.2(2), must have a service brake, a parking brake and an emergency brake, except a semi-trailer first registered before 1 November 1990 that must have a service brake only.

2.2(2) The following vehicles do not have to comply with 2.2(1):

- (a) a vehicle propelled by steam power;
- (b) a vehicle (including a crane and an excavator) fitted with self-laying tracks;
- (c) a traction engine;
- (d) a mechanically propelled roller;
- (e) a tractor or machine used solely in farm or roading operations whether for traction or otherwise, and not capable of a speed exceeding 30 km/h, together with any trailer used on the road only while drawn by that tractor or machine; a vehicle normally propelled by mechanical power while it is being temporarily towed without the use of its own power;
- (f) a vehicle normally propelled by mechanical power while it is being temporarily towed without the use of its own power;
- (g) an agricultural trailer.

2.2(3) Vehicles in 2.2(2)(a) to (e) must have a means by which the driver of the vehicle can control its movement and can stop and hold the vehicle stationary under all conditions of use.

2.2(4) A brake must:

- (a) be easily adjustable to compensate for wear or have a means of automatic adjustment; and
- (b) be maintained in good condition and efficient working order; and
- (c) enable the vehicle to comply with the requirements in 2.2(5), 2.2(8), 2.3(3), 2.3(5) to 2.3(7), 2.3(11) to 2.3(13) and 2.3(17), when the brake is applied by the driver:

- (i) on a hard dry surface that is free of loose material, and that is level except when the parking brake is applied on a slope; and
  - (ii) without assistance from the compression of the vehicle's engine or other auxiliary braking device in section 5 that is not part of the vehicle's service brake.
- 2.2(5) A brake that simultaneously applies braking pressure on two wheels with a common axis must be adjusted or fitted so that the braking effect is approximately the same on both wheels when the brake is applied by the driver, except if the braking effect is modulated by a control device to prevent the wheels locking or to improve stability.
- 2.2(6) A brake must be maintained within safe tolerance of its state when manufactured, having regard to the vehicle manufacturer's or brake manufacturer's Specification.
- 2.2(7) The friction materials of a brake must be:
- (a) secure; and
  - (b) in good condition; and
  - (c) free of defects that could noticeably and adversely affect the performance of the brake.
- 2.2(8) When a vehicle's brake is applied on a hard, dry, level surface that is free of loose material, and without assistance from the compression of the vehicle's engine or other auxiliary braking device in section 5 that is not part of the vehicle's service brake:
- (a) the vehicle or its controls must not vibrate so as to noticeably and adversely affect the control of the vehicle; and
  - (b) the braking effect on each braked wheel of the vehicle must provide stable and efficient braking without adverse effect on the directional control of the vehicle; and
  - (c) if the vehicle is equipped with an anti-lock braking system, the vehicle's rotationally sensed wheels must not lock, when the speed of the vehicle is above the ABS-activation parameters set by the vehicle manufacturer.
- 2.2(9) Except as provided in 2.2(10), a warning system that is fitted to a vehicle and is part of, or associated with the use of, a brake component or system must function correctly.
- 2.2(10) Subclause 2.2(9) does not apply to a brake pad wear-warning system, if the brake pads fitted to the vehicle cannot practically ensure correct functioning of the wear-warning system.

### 2.3 Requirements for different types of brake

#### *Service brake*

- 2.3(1) The service brake of a vehicle:
- (a) must be able to be applied by the driver from the driver's normal driving position in a controlled and progressive manner; and
  - (b) except for a heavy haulage trailer or a military trailer, must not have any device fitted by which the driver would be able to adjust the brake force distribution between the axles or between the vehicles that are used in a combination vehicle.
- 2.3(2) The service brake of a vehicle, whether or not it is being operated as a combination vehicle, must have one control only:
- (a) except as specified in 5.2(1); or
  - (b) unless the vehicle has been converted to dual steering, in which case the service brake control assembly must be replicated on the other side of the vehicle.
- 2.3(3) A service brake must, unless 2.3(5), 2.3(6) or 2.3(7) applies, be capable of stopping the vehicle at any load condition up to the gross vehicle mass or gross combination mass, as applicable, either:
- (a) within a distance ( $s$ ) in metres calculated by the following equation

$$s = 0.15v + \frac{v^2}{130}$$

where the speed of the vehicle ( $v$ ) in km/h before the start of braking is at least the lesser of 50 km/h or 80% of the maximum speed of the vehicle; or

- (b) within a distance of 7 m from a speed of 30 km/h.
- 2.3(4) A service brake of Class MD3, MD4, ME, NB, NC, TC and TD vehicles first registered in New Zealand on or after 1 November 1990 must act on each wheel
- 2.3(5) A vehicle that was first registered in New Zealand before 1 February 1977 and was manufactured with a service brake acting on two wheels only must be capable of stopping within a distance of 9 m from a speed of 30 km/h.
- 2.3(6) A vehicle that was manufactured before 31 December 1918 and that is not capable of exceeding a speed of 30 km/h under any condition of use must have a service brake that:
- (a) is capable of stopping the vehicle within a distance of 20 m from a speed of 30 km/h; or
  - (b) has a braking efficiency equivalent to that required in 2.3(6)(a).
- 2.3(7) A forklift must have a service brake that is capable of stopping the vehicle within a distance of:
- (a) 10 m when fully laden, or 9 m when unladen, from a speed of 30 km/h; or

- (b) 6 m when fully laden, or 4 m when unladen, from a speed of 20 km/h, if the forklift has a maximum speed of between 20 km/h and 30 km/h; or
  - (c) 6 m when fully laden, or 4 m when unladen, from the vehicle's maximum speed, if the forklift has a maximum speed of less than 20 km/h.
- 2.3(8) The stopping distances in 2.3(3), 2.3(5), 2.3(6)(a) and 2.3(7) are to be measured from the point at which movement of the brake control begins to the point at which the vehicle is brought to a complete stop.

#### *Parking brake*

- 2.3(9) The parking brake of a vehicle, whether or not it is being operated as a combination vehicle, must be able to be applied by the driver from the normal driving position using one control only.
- [2.3(9A) Despite 2.3(9), the parking brake control of a Class TC vehicle may be fitted to the vehicle if:
- (a) the vehicle is part of a dedicated combination and does not have an air brake or a brake that is operated with the assistance of compressed air; and
  - (b) the vehicle is fitted with a device that complies with 5.3(1); and
  - (c) the control is fitted in a readily accessible position; and
  - (d) the towing vehicle complies with 5.3(3).]

2.3(10) The parking brake of a vehicle first registered in New Zealand on or after 1 November 1990 must act on at least 40% of the wheels.

2.3(11) The parking brake of a vehicle, other than a semi-trailer, must, at any load condition up to the gross vehicle mass or gross combination mass, as applicable, be capable of:

    - (a) stopping the vehicle within a distance of 18 m from a speed of 30 km/h; or
    - (b) holding the vehicle stationary on a slope of [18%] whether facing uphill or downhill.

2.3(12) For a semi-trailer first registered in New Zealand on or after 1 November 1990, the total brake forces generated by the parking brake must be at least 20% of the maximum weight that can be carried on the axle or axle set.

2.3(13) A forklift must have a parking brake that is capable of holding the forklift stationary when:

    - (a) fully laden on a slope of 1 in 10; or
    - (b) unladen on a slope of 1 in 6.

#### *Emergency brake*

- 2.3(14) The emergency brake of a vehicle may be combined with either:
- (a) the parking brake; or
  - (b) the service brake of a powered vehicle, if the vehicle is fitted with a full dual-circuit service brake, and either:
    - (i) one of those circuits activates the brake on all the front wheels and the other circuit activates the brake on all the rear wheels; or
    - (ii) each circuit activates the brake on at least 1/3 of the wheels; or
  - (c) the service brake of a powered vehicle first registered in New Zealand during the period beginning on 1 November 1990 and ending on 31 December 1994, if the brake has not been modified since the vehicle was manufactured, the vehicle is fitted with a mechanically-operated parking brake acting on the transmission and the vehicle has either:
    - (i) a dual-line service brake that is fitted with a tandem/dual master cylinder; or
    - (ii) a single-line hydraulic service brake that is divided into two independent circuits through an excess flow-prevention valve, and the brake fluid reservoir is fitted with a low-level warning device.
- 2.3(15) The emergency brake of a trailer must operate immediately and automatically to stop and hold the trailer stationary if it becomes disconnected from the towing vehicle.
- 2.3(16) The emergency brake of a semi-trailer must, as far as is practicable, act on the wheels that remain in contact with the ground if the semi-trailer becomes disconnected from the towing vehicle during operation.
- 2.3(17) The emergency brake of a vehicle first registered in New Zealand on or after 1 November 1990 must:
- (a) act on at least 1/3 of the wheels, except as specified in 2.3(14)(b)(i);
  - (b) act as directly as practicable on those wheels without the interposition of any differential gearing;
  - (c) be capable of:
    - (i) stopping the vehicle at any load condition up to the gross vehicle mass or gross combination mass, as applicable, within a distance of 18 m from a speed of 30 km/h; or
    - (ii) for a semi-trailer, generating brake forces the sum of which is at least 20% of the maximum weight that can be carried on the axle or axle set.

## **2.4 Brake-testing requirements**

- 2.4(1) When a brake test is carried out to verify that the vehicle complies with the requirements in 2.3, the test results must verify, either directly or indirectly, that those requirements are complied with.
- 2.4(2) A brake test in 2.4(1) must be carried out, and the test results evaluated, in accordance with methods and conditions approved by the [Agency] by notice in the *Gazette*.

- 2.4(3) In determining whether the requirements in 2.3(3) to 2.3(17) are complied with, a vehicle inspector or inspecting organisation in 10.4 must take into account:
- evidence that the brake is within the vehicle manufacturer's or brake manufacturer's operating limits; and
  - the result, if available, of a brake test that is undertaken with a device approved under 10.6(1), subject to any condition placed on the use of the device.

2.4(4) The result of a brake test carried out in accordance with 2.4(3)(b) must be accepted as evidence of the brake's performance.

## 2.5 Approved vehicle standards for brakes

2.5(1) Subject to 2.5(5), a vehicle or its brake must comply, if required in section 6 or section 7, with the version of an approved vehicle standard that is:

- applicable in the relevant standard-setting jurisdiction to the date of manufacture of the vehicle or its brake equipment, or as specified in the standard; or
- a more recent version of that standard, if the safety performance of the vehicle is not adversely affected.

2.5(2) The approved vehicle standards for brakes are:

- Council Directive of 26 July 1971 on the approximation of the laws of the Member States relating to the braking devices of certain categories of motor vehicles and of their trailers (71/320/EEC)*;
- UN/ECE Regulation No. 13: Uniform provisions concerning the approval of vehicles of categories M, N and O with regard to braking (E/ECE324E/ECE/TRANS/505/Rev.1/Add.12)*;
- Federal Motor Vehicle Safety Standard No. 105: Hydraulic and electric brake systems*;
- Federal Motor Vehicle Safety Standard No. 121: Air brake systems*;
- Australian Design Rule 35, Commercial Vehicle Brake Systems*;
- Technical Standard for Brake Systems of Trucks and Buses (Japan)*;
- Technical Standard for Anti-Lock Brake System (Japan)*;
- Technical Standard for Brake Systems for Trailers (Japan)*.

2.5(3) An approved vehicle standard in 2.5(2) includes all amendments to that standard.

2.5(4) A vehicle, or its brake, is deemed to comply with an applicable approved vehicle standard, if it:

- complied with that standard when the vehicle was manufactured; and
- is currently within safe tolerance of its state when manufactured.

2.5(5) Despite 2.5(1)(a), a vehicle is not required to comply with an approved vehicle standard in this Rule if:

- the vehicle is manufactured before the phase-in date for the model, or model variant, of the vehicle in the relevant standard-setting jurisdiction or as specified in the standard;
- the model, or model variant, of the vehicle is not required by the vehicle standard itself to fully comply with that standard.

2.5(6) A vehicle that, under 2.5(5), does not have to comply with an approved vehicle standard must comply with the other applicable requirements of this Rule.

## 2.6 Approved standards for brake hoses and tubing

2.6(1) A hose or other flexible tubing forming part of the compressed air or vacuum lines of a vehicle brake must:

- comply with one or more of the approved vehicle standards in 2.6(2); or
- comply with a more recent version of that standard, if the safety performance of the vehicle is not adversely affected; or
- be of a make or kind approved by the [Agency] for the purpose to which it is applied.

2.6(2) The approved vehicle standards for brake hoses and flexible tubing are:

- SAE J844: Non-metallic Air Brake System Tubing*;
- SAE J1394: Metric Non-metallic Air Brake System Tubing*;
- SAE J1402: Automotive Air Brake Hose and Hose Assemblies*;
- SAE J1403: Vacuum Brake Hose (supersedes SAE 40 R3)*;
- British Standard AU 110: 1965, Specification for rubber hoses and hose assemblies for automotive air pressure brakes systems (withdrawn, revised)*;
- British Standard AU 109: 1965, Specification for vacuum brake hose (heavy duty) of oil-resistant rubber (withdrawn)*;
- Japan Industrial Standard D2606-80: Rubber hose for automotive air brake system*;
- DIN 74324-1: 1996, Air braking systems – Thermoplastic tubing – Requirements and tests*;
- DIN 73378: 1996, Polyamide tubing for motor vehicles*;
- Federal Motor Vehicle Safety Standard No. 106: Brake hoses*.

2.6(3) An approved standard in 2.6(2) includes all amendments to that standard.

*Section 3*  
*Air brake*

**3.1 Application of requirements**

A vehicle that is fitted with an air brake or a brake that is operated with the assistance of compressed air must comply with the requirements in this section.

**3.2 Use of compressed air**

A vehicle in 3.1 must be equipped with one or more

- (a) air compressors or other means of generating compressed air; and
- (b) air reservoirs or other means of storing compressed air; and
- (c) pressure gauges and pressure warning devices.

**3.3 Compressor capacity**

3.3(1) The compressor of a passenger service vehicle first registered in New Zealand on or after 10 February 1978 must be capable of raising, in not more than 90 seconds, the pressure in the air storage system from the pressure in 3.3(2) to the maximum operating pressure specified by the vehicle manufacturer or brake manufacturer at either:

- (a) the maximum governed speed of the vehicle's engine; or
- (b) an engine speed determined by a vehicle inspector or inspecting organisation, if the engine is not governed.

3.3(2) For the purposes of 3.3(1), the compressor capacity of the air brake must be measured by starting from the pressure to which the air brake falls from the maximum specified operating pressure as a result of five full service-brake applications made in accordance with 3.6(3).

3.3(3) The compressor of a vehicle, other than a passenger service vehicle, must be capable of raising the pressure in the air storage system to the maximum operating pressure specified by the vehicle manufacturer or brake manufacturer, at a speed specified in 3.3(1)(a) or (b), in not more than:

- (a) 3 minutes, starting from the pressure at which the low-pressure warning device ceases to operate, or when the emergency brake operates; and
- (b) 90 seconds, starting from the pressure to which the air brake falls from the maximum operating pressure, specified by the vehicle manufacturer or brake manufacturer, as a result of fully applying and releasing the service brakes five times in accordance with 3.6(3).

**3.4 Pressure warning devices**

3.4(1) A powered vehicle to which 3.5 applies, other than a passenger service vehicle first registered in New Zealand before 10 February 1978, must be fitted with a device that provides a continuous signal that is clearly visible or audible from the driver's normal driving position if any service brake reservoir is below the minimum safe operating pressure.

A powered vehicle to which 3.5 applies, other than a passenger service vehicle first registered in New Zealand before 10 February 1978, must be fitted with a device that provides a continuous signal that is clearly visible or audible from the driver's normal driving position if any service brake reservoir is below the minimum safe operating pressure.

[Note: "Minimum safe operating pressure" is defined in 3.8 below.]

3.4(2) The audible signal of the device in 3.4(1) may be rendered inoperative if the parking brake is fully applied or the vehicle is fitted with an automatic transmission and it is in the park position.

**3.5 Pressure gauges**

[3.5(1) A passenger service vehicle first registered in New Zealand on or after 10 February 1978 must be fitted with at least one gauge that:

- (a) is readily visible to the driver at all times from the driver's normal driving position;
- (b) indicates, to the driver, the pressure in at least one service brake reservoir.]

3.5(2) The compressed-air reservoir of the service brake of a passenger service vehicle that was first registered in New Zealand before 10 February 1978 must be fitted with:

- (a) a pressure gauge in 3.5(1); or
- (b) a visual warning device in 3.4.

[3.5(3) A powered vehicle, other than a passenger service vehicle, must be fitted with at least one gauge that:

- (a) is readily visible to the driver at all times from the driver's normal driving position; and
- (b) indicates, to the driver, the pressure in at least one service brake reservoir.]

3.5(4) A pressure gauge in 3.5(1) to 3.5(3) must indicate the pressure in pressure units, or on a coloured scale, or in an equivalent way

**3.6 Reservoir capacity**

3.6(1) The compressed-air reservoir capacity of a passenger service vehicle first registered in New Zealand on or after 10 February 1978, and of a powered vehicle other than a passenger service vehicle, must, when the air pressure in the brake is at its maximum operational pressure specified by the vehicle manufacturer or brake manufacturer and the compressor is stopped, enable the reserve of compressed air of the brake to provide:

- (a) at least five full service-brake applications with full release of the brakes after each application before the low pressure warning device operates; and
- (b) two full service-brake applications with full release of the brakes after each application following activation of the low pressure warning device.

[3.6(1A) The requirement for at least five full service-brake applications in 3.6(1)(a) may be reduced to four for a vehicle that complies with the approved standard in 2.5(2)(a) or (b).]

3.6(2) The requirement for at least five full service-brake applications in 3.6(1)(a) may be reduced to at least three before the emergency valve operates for a combination vehicle that is equipped with:

- (a) both:
  - (i) an emergency or a breakaway valve on the trailer; and
  - (ii) a tractor protection valve on the towing vehicle; or
- (b) other devices that are fitted to protect the air system of the towing vehicle and to activate the brake of the trailer when the trailer becomes disconnected from the towing vehicle.

3.6(3) For the purposes of 3.3(2), 3.3(3)(b), 3.6(1) and 3.6(2), a full service-brake application is made when all brake actuators on the vehicle are operated to apply their associated brakes in an effective manner.

### 3.7 Priority and protection of air brakes

3.7(1) The compressor must supply only the brake reservoirs with compressed air until the pressure in those reservoirs reaches the pressure specified by the vehicle manufacturer or the brake manufacturer, or, if such information is not available, two-thirds of the maximum operational pressure specified by the vehicle manufacturer or brake manufacturer.

3.7(2) An air brake must have priority of the supply of compressed air from the brake reservoir.

3.7(3) An air-operated device may be connected to the air brake of a vehicle, only if:

- (a) the brake is protected so that the operation or failure of the device cannot lower the pressure in [any service brake or parking brake reservoir(s)] below the pressure specified by the vehicle manufacturer or brake manufacturer, or, if such information is not available, two-thirds of its maximum operational pressure specified by the vehicle manufacturer or brake manufacturer; and
- (b) the supply to the device is drawn from a reservoir separate from [the service brake or parking brake reservoir(s)] supplying the brake, except as specified in 3.7(4).

3.7(4) Despite 3.7(3)(b), an air-operated device may be supplied with compressed air from [the service brake or parking brake reservoir(s)], if:

- (a) the operation of the device requires only a small amount of compressed air and it is supplied with compressed air by a hose or pipe with an external diameter not exceeding 8 mm; or
- (b) the device is operated only when the vehicle is stationary; or
- (c) the vehicle manufacturer allows it.

[3.7(5) If a vehicle to which 3.4 applies has more than one compressed-air service or parking brake circuit, a failure in any service or parking brake circuit that lowers the pressure in any service or parking brake reservoir, below the minimum safe operating pressure, must not reduce the pressure in any other service or parking brake reservoir below the minimum safe operating pressure.]

### 3.8 Minimum safe operating pressure

In this section, **minimum safe operating pressure** means:

- (a) the minimum safe operating pressure specified by the vehicle manufacturer or brake manufacturer; or
- (b) if no minimum safe operating pressure is specified by the vehicle manufacturer or brake manufacturer, 50% of the correctly adjusted cut-out pressure for the compressor-governor.]

## *Section 4*

### *Hydraulic brake*

4.1(1) A vehicle fitted with an hydraulic brake, whether or not the operation of the brake is assisted by compressed air, vacuum or other means of energy, must comply with the requirements in this section.

4.1(2) The volume of the hydraulic fluid supplied by the master cylinder or booster cylinder of an hydraulic brake during a single stroke must be sufficient for the effective operation of the wheel brakes, even if all wheel brakes are worn to the permitted wear limit or are in the permitted maximum out-of-adjustment position.

4.1(3) A passenger service vehicle first registered in New Zealand on or after 10 February 1978, or a vehicle of Class NB or Class NC first registered in New Zealand on or after 1 November 1990, that has a parking brake acting solely through the transmission and is fitted with an hydraulic service brake, must have a dual or tandem master cylinder that allows:

- (a) one of those cylinders to actuate the brakes on the front wheels of the vehicle and the other cylinder to actuate the brakes on the rear wheels of the vehicle; or
- (b) each circuit to activate the brake on at least 1/3 of the wheels.

4.1(4) A passenger service vehicle first registered in New Zealand on or after 1 September 1954, fitted with a brake that is operated by pump-generated hydraulic pressure, must be fitted with the following devices that provide to the driver a signal that is

clearly audible and readily visible from the driver's normal driving position to ensure that, at all times, the driver is aware immediately that the hydraulic pressure is less than the pressure necessary for the safe operation of the vehicle:

- (a) an audible warning device; and
- (b) either:
  - (i) a warning lamp; or
  - (ii) a suitable pressure gauge that is able to indicate both the maximum and minimum pressures being used.

4.1(5) A passenger service vehicle with more than nine seating positions first registered in New Zealand on or after 10 February 1978, which utilises vacuum to boost the force supplied by the driver to apply the brakes and is fitted with a vacuum reservoir, must be equipped with:

- (a) a warning device to give a continuous signal audible to the driver if the vacuum in the reservoir is less than 25 kPa or its equivalent; and
- (b) a vacuum gauge to indicate to the driver, in kilopascals or other units, the vacuum available in the reservoir.

### Section 5

#### *Auxiliary brakes and controls*

#### 5.1 Retarders and engine brakes

5.1(1) A vehicle may be fitted with a retarder or engine brake to control the speed of the vehicle.

5.1(2) A retarder or an engine brake fitted on or after 1 March 2007 must:

- (a) have a control that can be operated from the driver's normal driving position; and
- (b) be designed so that:
  - (i) its operation does not cause wheelslip that could result in loss of directional control of the vehicle; or
  - (ii) the retardation can be regulated by the driver using the control to prevent wheelslip that could result in loss of directional control of the vehicle.

5.1(3) A retarder or an engine brake of a powered vehicle, which activates the brake of a trailer that is being towed, must not cause wheelslip on the vehicle that could result in loss of directional control.

#### 5.2 Additional brake control devices

5.2(1) A powered vehicle that is being operated as a combination vehicle may be fitted with a trailer-brake hand control.

5.2(2) A trailer-brake hand control:

- (a) must be capable of applying the service brake of the trailer or trailers in a progressive manner; and
- (b) must automatically return to its original position when released; and
- (c) must not prevent the safe operation of the service brake of any of the vehicles in the combination vehicle.

5.2(3) A trailer may be fitted with a device that:

- (a) allows the release of its parking brake even when the brake of the trailer is not connected to the brake of the towing vehicle; and
- (b) ensures that the parking brake of the trailer is automatically applied when the trailer's brake is reconnected to the brake of the towing vehicle and the parking brake is reapplied.

#### 5.3 Devices to keep a vehicle stationary for a limited time

5.3(1) A vehicle may be fitted with a device that can be operated by the driver from the driver's normal driving position to keep the vehicle stationary temporarily, provided that the device does not prevent the safe operation of the service brake or the parking brake of the vehicle.

5.3(2) A device in 5.3(1) may utilise the service brake by:

- (a) applying the service brake, either partially or fully, on some or all of the vehicle's wheels; or
- (b) preventing the release of the service brake, when applied by the driver, on some or all of the vehicle's wheels.

5.3(3) A device in 5.3(1) which can only be de-activated by the driver must have a label permanently attached displaying the words: "NOT FOR PARKING".

5.3(4) A device in 5.3(1) which can be de-activated by the control system of the vehicle must either have:

- (a) a label permanently attached displaying the words: "NOT FOR PARKING"; or
- (b) an audible warning device that operates when the driver's door is open while the device is activated and the parking brake is not fully applied.

### Section 6

#### *Additional requirements for vehicles not used in combination with other heavy motor vehicles*

6.1(1) A vehicle of Class MD3, MD4, ME, NB or NC manufactured or modified in New Zealand on or after 1 July 2008 in a way that affects the safety performance of a brake, and that does not have a towing connection to tow a vehicle of Class TC or Class TD must comply with 61(2).

6.1(2) For a vehicle in this section, compliance of the service brake with the requirements in 2.2(8)(b) and 2.3(3)(a) must be demonstrated by either:

- (a) certification for compliance with the requirements in Schedule 5; or

- (b) stopping tests:
    - (i) under the conditions in 2.2(8); and
    - (ii) with the vehicle in an unladen and in a heavily laden condition; and
    - (iii) from a speed of at least 50 km/h; and
    - (iv) generating a peak deceleration of at least 0.45g without any wheel locking when the service brake is applied
- 6.1(3) An imported vehicle of Class MD3, MD4, ME, NB or NC first registered in New Zealand on or after 1 July 2008 and that does not have a towing connection to tow a vehicle of Class TC or Class TD must comply with one or more of the approved vehicle standards in 2.5(2).

### *Section 7*

#### *Additional requirements for vehicles used in combination with other heavy motor vehicles*

#### **7.1 Additional requirements for towing vehicles**

- 7.1(1) The brake of a vehicle of a class in Table A that has been fitted with a towing connection to tow a vehicle of Class TC or Class TD must comply with 7.1.
- 7.1(2) A vehicle in 7.1(1) certified for compliance with one of the Codes or Specifications in Schedules 1 to 4 before 1 March 2007 must continue to comply with that Code or Specification, if that vehicle:
- (a) has not been modified on or after 1 March 2007; and
  - (b) is being operated in a combination vehicle that has a gross mass exceeding 39,000 kg but not exceeding 44,000 kg.
- 7.1(3) A vehicle in 7.1(1) first registered in New Zealand after 1 March 2007 and before 1 July 2008 that is being operated in a combination vehicle that has a gross mass exceeding 39,000 kg but not exceeding 44,000 kg, must comply with:
- (a) the New Zealand Heavy Vehicle Brake Code, Second Edition (1997) in Schedule 4; or
  - (b) the Interim Specification for Heavy Vehicle Braking in Schedule 1; or
  - (c) the requirements with which a vehicle of the same class must comply if first registered in New Zealand or modified in New Zealand on or after 1 July 2008.
- 7.1(4) An imported vehicle of Class NB or Class NC to which 7.1(1) applies that is first registered in New Zealand on or after 1 July 2008 must comply with:
- (a) at least one of the approved vehicle standards in 2.5(2)(a) or (b); and
  - (b) Subclause 7.1(6); or
  - (c) all of the following:
    - (i) one or more of the approved vehicle standards in 2.5(2)(c), (d), (e), (f) and (g); and
    - (ii) be fitted with an anti-lock braking system except for a logging vehicle, provided that the standard with which it complies does not require an ABS function; and
    - (iii) Subclause 7.1(6).
- 7.1(5) A vehicle of Class NB or Class NC in 7.1(1) that is manufactured in New Zealand and is first registered on or after 1 July 2008, or a vehicle of Class NB or Class NC modified in New Zealand on or after that date, must comply with 7.5.
- 7.1(6) A vehicle in 7.1(3), 7.1(4) or 7.1(5) that is fitted with an air brake must, when the trailer becomes disconnected from the towing vehicle, have a means by which:
- (a) the air brake of the towing vehicle is protected from the loss of air pressure; and
  - (b) the air brake of the trailer is activated.
- 7.1(7) A vehicle of Class TC or Class TD in 7.1(1) first registered or modified in New Zealand on or after 1 July 2008 must comply with the requirements in 7.5.
- 7.1(8) An air-braked vehicle in 7.1, except a vehicle that complies with the Interim Specification for Heavy Vehicle Braking in Schedule 1, or a vehicle that has an electronic control device which is capable of regulating and optimising vehicle deceleration according to an electrical signal provided by the driver's brake control, must have a threshold pressure [between 55 and 80 kPa (inclusive)].

#### **7.2 Additional requirements for trailers**

- 7.2(1) The brake of a vehicle of Class TC or Class TD must comply with 7.2.
- 7.2(2) A vehicle in 7.2(1) certified for compliance with one of the Codes or Specifications in Schedules 1 to 4 before 1 March 2007 must continue to comply with that Code or Specification, if that vehicle:
- (a) has not been modified on or after 1 March 2007; and
  - (b) is being operated in a combination vehicle that has a gross mass exceeding 39,000 kg, but not exceeding 44,000 kg.
- 7.2(3) A vehicle in 7.2(1) first registered in New Zealand or modified on or after 1 March 2007 and before 1 July 2008 that is being operated in a combination vehicle with a gross mass exceeding 39,000 kg but not exceeding 44,000 kg, must comply with either:
- (a) the New Zealand Heavy Vehicle Brake Code, Second Edition (1997) in Schedule 4; or
  - (b) the Interim Specification for Heavy Vehicle Braking in Schedule 1; or
  - (c) the requirements in 7.5.

- 7.2(4) A vehicle of Class TC or Class TD in 7.2(1) first registered in New Zealand on or after 1 July 2008, or modified on or after that date, must comply with the requirements in 7.5.
- 7.2(5) An air-braked vehicle in 7.2, except a vehicle that complies with the Interim Specification for Heavy Vehicle Braking in Schedule 1, or a vehicle that has an electronic control device which is capable of regulating and optimising vehicle deceleration according to an electric signal provided by the driver's brake control, must have a threshold pressure [between 55 and 80 kPa (inclusive)].

### **7.3 Requirements for the connection of the air brake of vehicles in a combination vehicle**

- 7.3(1) The air brake of a vehicle first registered in New Zealand on or after 1 March 2007 or modified on or after that date that can be operated in a combination vehicle must be capable of being connected to the air brake of the other vehicle by means of a two-line system.
- 7.3(2) A two-line system must consist of:
- (a) a supply line that supplies compressed air from the towing to the towed vehicle; and
  - (b) a control line that supplies a control signal, in the form of modulated air pressure, to regulate the intensity of the brake application on the towed vehicle or vehicles.
- [7.3(3) For vehicles towing semi-trailers and for semi-trailers, the hoses connecting the towed and towing vehicles are to be considered as part of the towing or towed vehicle or to be detachable at both ends.]
- 7.3(4) For vehicles other than those towing semi-trailers, the hoses are to be treated as part of the trailer and must be securely attached to the drawbar
- 7.3(5) A towing vehicle and a towed vehicle in 7.3(1) must be fitted with a coupling device, approved under 10.6(3), to connect the brake to, and disconnect it from, that of the other vehicle, and that device must:
- (a) be robust, durable, and suitable for automotive application; and
  - (b) prevent, either through the design of the coupling device or through its installation, the incorrect connection of the control and supply lines; and
  - (c) not adversely affect the performance of the brake of either the towing or towed vehicle(s); and
  - (d) have an effective breakaway function.
- 7.3(6) Subject to 7.3(8), if a vehicle is fitted with a Duomatic- or Triomatic-type coupling device, the control line in 7.3(2) must be connected to the port of the coupling device that is closest to the opening handle.
- 7.3(7) Subject to 7.3(8), if a vehicle is fitted with a Duomatic- or Triomatic-type coupling device, the supply line in 7.3(2)(a) must be connected to:
- (a) the middle port of the Triomatic coupling device; or
  - (b) the port of the Duomatic coupling device that is farthest away from the opening handle.
- 7.3(8) A vehicle, other than one that complies with the Interim Performance Specification for Heavy Vehicle Braking in Schedule 1, that has been fitted with a Duomatic- or Triomatic-type coupling device before 1 July 2008 and that was not required to comply with the requirements in 7.3(6) and 7.3(7), must comply with these requirements by the date on which the first certificate of fitness inspection is due on or after 1 July 2008.
- 7.3(9) The socket of a Duomatic- or Triomatic-type coupling device must be fitted:
- (a) to the rear of a towing vehicle; and
  - (b) to the front of a semi-trailer.
- 7.3(10) The socket of a coupling device in 7.3(5) must be fitted as close as practicable to:
- (a) the centre-line of the vehicle; and
  - (b) the towing connection by which the towed and towing vehicles are connected.
- 7.3(11) The socket of a coupling device in 7.3(5) that is fitted to the front of a semi-trailer must not be fitted with a non-return valve.
- 7.3(12) The fitting of a coupling device in 7.3(5) must be carried out having regard to the instructions of the vehicle manufacturer.

### **7.4 Requirements for anti-lock brake systems (ABS)**

- 7.4(1) An anti-lock braking system of a vehicle of Class NB, NC, [TC or TD] first registered in New Zealand on or after 1 July 2008, or that was fitted to a vehicle of those classes in New Zealand on or after that date, must be capable of continuously controlling and adjusting the braking effort on the wheels during braking to prevent:
- (a) the wheels from locking; and
  - (b) the loss of directional control of the vehicle that could be caused by the application of the brake.
- 7.4(2) A control device in 7.4(1) must meet the technical requirements in
- (a) one or more of the approved vehicle standards in 2.5(2), if those standards specify requirements for that device; or
  - (b) 7.4(3) to 7.4(7).
- 7.4(3) A control device to which 7.4(2)(b) applies must act on each axle and must be capable of modulating the brake force separately for:
- (a) each axle set; and
  - (b) each side of all axle sets except steering axles.

- 7.4(4) A control device to which 7.4(2)(b) applies must have sensors to monitor the rotational speed of the wheels.
- 7.4(5) The sensors in 7.4(4) must be fitted to at least one wheel on each side of all axle sets.
- 7.4(6) If an axle set consists of more than one axle, the sensor in 7.4(4) must be fitted as follows:
- (a) if the axle set consists of two axles and they are designed to carry the same or a similar load, the sensors must be fitted to the axle on which the wheels are more likely to lock during braking;
  - (b) if the axle set consists of two axles and they are designed to carry significantly different loads, the sensors must be fitted to the axle that carries the greater load;
  - (c) if the axle set consists of more than two axles and they are designed to carry the same or a similar load, the sensors must be fitted to the axle on which the wheels are neither the most likely nor the least likely to lock during braking;
  - (d) if the axle set consists of more than two axles and one of them is designed to carry a significantly greater load than other axles in the set, the sensors must be fitted to the axle that carries the greatest load;
  - (e) if the axle set consists of more than two axles and two or more of them carry a greater load than the remaining axle or axles in the set, the sensors must be fitted to an axle:
    - (i) that is one of the axles carrying a greater load; and
    - (ii) the wheels of which are most likely to lock;
  - (f) if the axle set consists of more than two axles and two or more of them carry a greater load than the remaining axle or axles in the set and the likelihood that their wheels will lock is similar, the sensors may be fitted to any of the axles that carries the greater load;
  - (g) if the axle set consists of two or more axles that carry a similar load, and the likelihood that their wheels will lock is similar, the sensors may be fitted to any of the axles.
- 7.4(7) A control device in 7.4(1) that is fitted to a trailer of Class TC or Class TD must:
- (a) comply with the requirements in 7.4, without being connected to the control device of the towing vehicle; and
  - (b) be capable of being supplied with power for its operation by means of an electric cable from the towing vehicle.
- 7.4(8) The power connection between vehicles that can be operated in a combination vehicle must comply with Parts 1 and 2 of *ISO 7638: 1997, Road vehicles – Electrical connectors for braking systems*.
- 7.5 Specific performance requirements for vehicles manufactured or modified in New Zealand**
- 7.5(1) A vehicle to which 7.1(5), 7.1(7), 7.2(3)(c) or 7.2(4) applies must, in addition to complying with the other applicable requirements in this Rule, comply with 7.5.
- 7.5(2) The brake force applied to a wheel of a vehicle in 7.5(1) during braking on a hard, dry, clean and level surface must:
- (a) for a vehicle without ABS other than one in 7.5(2)(c), be approximately proportional to the load on the wheel, taking into account the dynamic load transfer that occurs during braking between the axles of a vehicle and that also may occur between the vehicles of a combination vehicle, at all conditions of loading up to the vehicle's gross vehicle mass;
  - (b) for a vehicle with ABS, be approximately proportional to the load on the wheel without relying on the operation of ABS, taking into account the dynamic load transfer that occurs during braking between the axles of a vehicle and that also may occur between the vehicles of a combination vehicle, when the vehicle is loaded to its gross vehicle mass;
  - (c) for a Class TC vehicle, a logging vehicle, a heavy haulage trailer or a military trailer, be the brake force specified in 7.5(2)(a) only when the vehicle is loaded to its gross vehicle mass, even if ABS is not fitted.
- 7.5(3) A vehicle complies with the requirements in 7.5, if it has been certified for compliance with the requirements in Schedule 5 and is within safe tolerance of its state when certified.

## *Section 8*

### *Modification*

#### **8.1 General requirements for modification**

- 8.1(1) Section 8 applies to all modifications carried out on or after 1 March 2007.
- 8.1(2) A modification to a vehicle's brake must not prevent the brake from complying with this Rule.
- 8.1(3) The modification of a brake, such as adding or removing a brake component or system, or altering the setting of a brake component or system, must not adversely affect the performance of the brake.
- 8.1(4) When a vehicle is modified in a way that may affect compliance with this Rule, such as altering a vehicle's wheelbase, the performance of the brake must be checked and modified if necessary to ensure continued compliance with this Rule.
- 8.1(5) A vehicle that is modified by fitting an additional axle, removing an axle, replacing an axle with one that is not of the same make and model, or replacing the brake of an axle with one that is not of the same make and model, must either:
- (a) be modified so as to continue to meet the technical and performance requirements of the approved standard in 2.5(2) with which the vehicle originally complied; or
  - (b) comply with all other applicable requirements in this Rule.
- 8.1(6) A powered vehicle with an hydraulic service brake may be fitted with an additional rear axle that has an air operated disc brake as a service brake.

**8.2 Modifications that do not require specialist certification**

The following modifications do not require specialist certification:

- (a) an adjustment of the brake system for the purpose of complying with 7.1(8) or 7.2(5);
- (b) the replacement of an air brake coupling device on a powered vehicle for the purpose of complying with 7.3;
- (c) the fitting of an air brake coupling device to a powered vehicle that is carried out:
  - (i) for the purpose of complying with 7.3; and
  - (ii) in accordance with the manufacturer's recommendations;
- (d) the fitting of a valve to a powered vehicle to allow the parking brake of any towed trailer(s) to operate.]

*Section 9**Repair and replacement parts***9.1 Repair**

- 9.1(1) A repair to a brake, or to a vehicle that affects its braking performance, must comply with this Rule and with Land Transport Rule: Vehicle Repair 1998.
- 9.1(2) When a brake lining or a brake pad on an axle is replaced:
  - (a) all the brake linings or brake pads on that axle must be replaced; and
  - (b) all replacement brake linings and brake pads on that axle must be of the same make, type and grade.

**9.2 Replacement components for vehicle repair**

- 9.2(1) Subclauses 9.2(2) and 9.2(3) apply to any component that affects the braking performance of a vehicle and that is:
  - (a) manufactured, stocked or offered for sale in New Zealand; and
  - (b) supplied for fitting to a vehicle to be operated on a New Zealand road.
- 9.2(2) A component used in a repair must have equivalent performance characteristics to that of the original component and must not prevent a vehicle from complying with this Rule.
- 9.2(3) A brake lining assembly used as a replacement component, whether or not the brake to which it is fitted is required to comply with an approved vehicle standard, complies with this Rule if it complies with *UN/ECE Regulation No. 90, Uniform Provisions concerning the approval of replacement brake lining assemblies and drum brake linings for power-driven vehicles and their trailers (E/ECE/324E/ECE/TRANS/505/Rev.1/Add.89)*.

*Section 10**Responsibilities***10.1 Responsibilities of operators**

A person who operates a vehicle must ensure that the vehicle complies with this Rule.

**10.2 Responsibilities of repairers**

A person who repairs or adjusts a brake must ensure that the repair or adjustment:

- (a) does not prevent the vehicle from complying with this Rule; and
- (b) complies with Land Transport Rule: Vehicle Repair 1998.

**10.3 Responsibilities of modifiers**

A person who modifies a vehicle so as to affect the braking performance of the vehicle must:

- (a) ensure that the modification does not prevent the vehicle from complying with this Rule; and
- (b) notify the operator that the vehicle must be inspected and, if necessary, certified by a person or organisation appointed to carry out specialist inspection and certification of heavy vehicle brakes.

**10.4 Responsibilities of vehicle inspectors and inspecting organisations**

- 10.4(1) A vehicle inspector or inspecting organisation must not certify a motor vehicle under Land Transport Rule: Vehicle Standards Compliance 2002 if they have reason to believe that the vehicle does not comply with this Rule.
- 10.4(2) During the certification of a vehicle, compliance of a vehicle's brakes with the performance requirements in this Rule must be verified by means of appropriate tests, using approved testing devices and following correct test procedures.
- 10.4(3) For a vehicle to which 2.3(3) applies, if a vehicle inspector or inspecting organisation has reason to believe that there is an excessive delay between the time the driver starts to actuate the brake control and when effective braking starts, compliance with the stopping-distance requirements must be verified by measuring the stopping distance as specified in 2.3(8).

**10.5 Responsibilities of manufacturers and retailers**

A person may manufacture, stock, or offer for sale a brake or its components, intended for fitting to a vehicle to be used on a New Zealand road, only if that brake or component:

- (a) complies with this Rule; and
- (b) does not prevent a repair to a vehicle, its structure, systems, components and equipment from complying with this Rule.

**10.6 Functions and powers of the [Agency]**

- 10.6(1) The [Agency] may approve, by notice in the *Gazette*, devices for the purpose of measuring brake performance and may place conditions on the use of those devices.

- 10.6(2) The [Agency] may approve, by notice in the *Gazette*, testing equipment, methods and conditions, and test result valuation methods, for the purpose of verifying that a vehicle complies with performance requirements in 2.3.
- 10.6(3) The [Agency] may approve coupling devices for the purpose of connecting the air brake of a towing vehicle and towed vehicle if those devices meet the criteria in 7.3(5)(a) to (d).
- 10.6(4) The [Agency] may, by notice in the *Gazette*, specify a method for determining that replacement brake friction material complies with this Rule.
- 10.6(5) [The Agency] may direct a person in 10.5 to recall a replacement component, if the [Agency is satisfied on reasonable grounds] that the component does not comply with this Rule, and may direct that person to bear the costs associated with the recall.
- 10.6(6) [The Agency] may revoke, by giving written [notice, a record of determination issued after specialist inspection and certification that a vehicle complies with this Rule, if the [Agency is satisfied] on reasonable grounds that the applicable requirements have not been complied with.
- 10.6(7) The [Agency] may approve, by notice in the *Gazette*, a hose or other flexible tubing for the purpose of fitting it to the compressed-air or vacuum line of a brake.
- 10.6(8) The [Agency] may approve, by notice in the *Gazette*, computer software for the purpose of demonstrating compliance with the requirements in Schedule 5.
- [Note: A breach of a responsibility in this section is an offence, as provided in the Land Transport (Offences and Penalties) Regulations 1999, and is subject to a penalty as specified in those regulations.]

## Part 2

### Definitions

**[Agency]** means the New Zealand Transport Agency established under section 93 of the Land Transport Management Act 2003]  
**Agricultural trailer** means a trailer constructed to be operated in connection directly with the operation or management of a farm; but does not include a logging trailer.

**Air brake** means a brake, the operation of which requires the use of compressed air.

**Anti-lock braking system (ABS)** means a device that senses that one or more of the wheels is starting to lock-up during braking and regulates the braking forces automatically and effectively to prevent it.

**Approved vehicle standard** means a vehicle standard in 2.5(2), 2.6(2) and 9.2(3).

**Auxiliary brake** means a device, other than a service brake or parking brake, fitted to a vehicle to enable the driver to control its speed, whether or not it is suitable to stop the vehicle.

**Average deceleration** for the purpose of this Rule, means the average deceleration during braking, which is either the mean value of deceleration during braking or the deceleration calculated from the distance travelled during the period when the deceleration occurred and the difference between the speed immediately before and after that.

**Axle** means one or more shafts, spindles, or bearings in the same vertical transverse plane by means of which, in conjunction with wheels mounted on those shafts, spindles, or bearings, a portion of the weight of the vehicle is transmitted to the roadway, and:

- (a) if two or more wheels of a motor vehicle are substantially in the same line transversely and some or all of them have separate axles, the axles of all those wheels are to be treated as one axle;
- (b) if the longitudinal centre-line of an axle of a motor vehicle is less than 1 m distant from the longitudinal centre-line of another axle, the two axles are to be treated as one axle (**a dual axle**).

**Axle set** means a single axle set, a tandem axle set, a twin-steer axle set, a tri-axle set or a quad-axle set.

**Brake** means the combination of parts whose function is to reduce the speed of the vehicle, to stop the vehicle or to keep the vehicle stationary.

**Brake coupling** means the device for connecting the control and supply lines of the towing vehicle to the control and supply lines of the trailer.

**Brake lining** means a brake lining in the case of a drum brake, and a brake pad in the case of a disc brake.

**Brake lining assembly** means a component of a friction brake, including a brake lining and its backing plate or a brake lining and its brake shoe that is pressed against the brake disc or drum to produce friction force.

**Braking force** means the retarding force generated by a brake assembly.

**Certificate of loading** means a certificate of loading issued under any regulation or Rule made under the Land Transport Act 1998.

**Certify** has the same meaning as in Land Transport Rule: Vehicle Standards Compliance 2002.

**Chassis** means the structural lower part of a vehicle to which the running gear and, as applicable, engine, transmission, steering system and body may be attached.

**Circuit** means the combination of components that functionally links the brake control and the foundation brake. The circuit may be mechanical, hydraulic, pneumatic, electrical, or a mix of these.

**Class** in relation to vehicles, means a category of vehicle of one of the Groups A, L, M, N and T, as specified in Table A: Vehicle classes.

**Combination vehicle** means a towing vehicle in combination with one or more trailers.

**Construction** means the manufacture, assembly, reassembly, or modification of a vehicle; and includes all acts and activities related or incidental to the construction of a vehicle.

**Control** means the part of the brake actuated directly by the driver to regulate the operation of the brake.

**Control (service) line** means the part of the circuit that transmits the service brake signal within a vehicle and also between vehicles being operated as a combination vehicle.

**Coupling** means that part of a vehicle that is specifically designed to enable it to be connected to another vehicle; and does not include a structural member of the towing or towed vehicle.

**Deceleration** means the rate of speed reduction over time.

**[Dedicated combination** means a combination of vehicles certified for use in combination where both vehicles are affixed with a plate clearly and indelibly marked with the VIN or chassis number of the other vehicle.]

**Director:** *Definition Revoked*

**Drawbar** means an assembly of components that includes the trailer coupling that connects the trailer to the coupling of the towed vehicle, hinges (where applicable) and the structural and other related components between the trailer coupling and trailer bogie or chassis.

**EEC, EC** are abbreviations for directives of the European Economic Community and, later, the European Communities.

**Emergency brake** in relation to any vehicle, or combination of vehicles, means the system that makes it possible to undertake a controlled stop of the vehicle or combination in the event of the failure of the service brake.

**Engine brake** means a device or feature of an engine to increase, when applied, the retardation force provided by the engine that can be utilised to control the speed of the vehicle.

**Federal Motor Vehicle Safety Standard** is a vehicle standard of the United States of America.

**Forklift** means a motor vehicle (not fitted with self-laying tracks) designed principally for lifting, carrying and stacking goods by means of one or more tines, platens, or clamps.

**Foundation brake** means the basic brake assembly fitted to each axle or wheel which produces the braking force necessary to bring a vehicle to a stop; and includes the complete drum or disc brake.

**Friction material** means a brake component having a friction surface that is designed to be preferentially sacrificed.

**Friction surface** means any surface of a brake component that is designed to convert kinetic energy to heat.

**Goods** means all kinds of movable personal property; and includes articles sent by post, and animals.

**gross combination mass** means, for a vehicle that is permitted to tow another vehicle, the maximum permitted combined mass of the towing vehicle and any combination of attached trailers or vehicles, determined by the vehicle manufacturer and approved by the [Agency], or determined by the [Agency].

**gross mass** in relation to any vehicle or combination vehicle, means the mass of that vehicle and its load, equipment, and accessories, which may be determined by adding the mass on the vehicle's axles or axle sets.

**gross vehicle mass** means either:

- (a) the maximum permitted mass of a vehicle, which includes the mass of the accessories, the crew, the passengers and load, and is, unless (b) applies, the gross vehicle mass specified (subsequent to the latest modification, if any) by the manufacturer of the vehicle; or
- (b) if a person approved for the purpose by the [Agency] determines that the gross vehicle mass should differ from that specified by the manufacturer, taking into account evidence on the capability of the systems and components of the vehicle, or the effects of any modification, that mass determined by that person.

**Heavy haulage trailer** means a trailer that is fitted with an hydraulic suspension system that allows the adjustment of the ride height, and for which the pressure in the hydraulic system varies significantly at any given load condition of the trailer depending solely on the ride height.

**Heavy motor vehicle** means a motor vehicle that:

- (a) is of Class MD3, MD4, ME, NB, NC, TC or TD; or
- (b) has a gross vehicle mass that exceeds 3500 kg and is not of a class specified in Table A: Vehicle classes.

**Hydraulic brake** means a brake that utilises hydraulic pressure to activate the foundation brake, whether its operation is assisted by compressed air, vacuum or any other means.

**Load** includes part of a load; and

- (a) includes covers, ropes, ties, blocks, tackles, barrows, or other equipment or object used in the securing or containing of loads on vehicles or the loading or unloading of vehicles, whether or not any other load is on the vehicle; but
- (b) does not include animal wastes discharged from animals being carried on a vehicle at the time.

**Load-sharing axle set** means an axle set suspension system that has effective damping characteristics on all axles of the set and is built to divide the load between the tyres on the set so that no tyre carries a mass more than 10% greater than the mass it would carry, if:

- (a) the load were divided in the axle set so that each tyre carries an equal load; or
- (b) the axle set is a tandem axle set comprising a twin-tyred axle and a large single-tyred axle and is built to divide the load between the tyres on the set so that:

- (i) 60% of the load is borne by the twin-tyred axle and 40% of the load is borne by the large single-tyred axle; or
- (ii) 55% of the load is borne by the twin-tyred axle and 45% of the load is borne by the large single-tyred axle.

**Logging vehicle** means a vehicle that is constructed exclusively for transporting timber logs using permanently fitted log bolsters.

**Manufacturer's operating limits** means:

- (a) in relation to a motor vehicle, the allowance provided by the vehicle manufacturer in terms of performance capability and dimensions, relative to deterioration, malfunction or damage beyond which the safe performance of the vehicle, as defined by the vehicle manufacturer, is compromised; and
- (b) in relation to a system, component or item of equipment, incorporated in or attached to a vehicle, the allowance provided by the system, component or equipment manufacturer in terms of performance capability and dimensions, relative to the deterioration, malfunction or damage, beyond which the safe performance of the system, component or item of equipment (and consequently the vehicle) is compromised.

**Mass in relation to a vehicle**, means the quantity of material contained in or on the vehicle that, when subjected to acceleration due to gravity, will exert downwards on a level surface a force that can be measured as the weight of the vehicle.

**Military trailer** means a trailer that is used exclusively as equipment of the New Zealand Defence Force.

**Modify** in relation to a vehicle, means to change the vehicle from its original state by altering, substituting, adding or removing any structure, system, component or equipment; but does not include repair.

**Motor vehicle** has the same meaning as in section 2(1) of the Land Transport Act 1998.

**Operate** in relation to a vehicle, means to drive or use the vehicle on a road, or to cause or permit the vehicle to be on a road or to be driven on a road, whether or not the person is present with the vehicle.

**Parking brake** means a brake that is designed for keeping the vehicle stationary, and that is readily applicable and capable of remaining applied for an indefinite period without further attention.

**Phase-in date** means the date specified in an approved vehicle standard from which a model, or model variant, of a vehicle must comply with that standard or part of that standard.

**Quad-axle set** means a set of four axles, where:

- (a) the centres of the first and fourth axles are spaced not less than 3.75 m, and not more than 4 m apart; and
- (b) all axles contain an equal number of tyres; and
- (c) none of the axles is a single standard-tyred axle.

**Repair** means to restore a damaged or worn vehicle, its structure, systems, components or equipment; and includes the replacement of damaged or worn structures, systems, components or equipment with equivalent undamaged or new structures, systems, components or equipment.

**Reservoir** means a device designed and constructed to store fluid, compressed air, compressed gas, or vacuum; and does not include pipes, valves, hoses, or booster cylinders operated by vacuum or compressed air.

**Retarder** means a device permanently fitted to a vehicle to provide, when applied, a continuous braking effort not generated by a brake.

**SAE** is an abbreviation for a standard of the American Society of Automotive Engineers.

**Safe tolerance** means the tolerance within which the safe performance of the vehicle, its structure, systems, components or equipment is not compromised, having regard to any manufacturer's operating limits.

**Semi-trailer** means a trailer, with only one axle set, that is partially superimposed on the towing vehicle so that a substantial part of the trailer and its load is borne by the towing vehicle.

**Service brake** means a brake for intermittent use that is designed for the purpose of slowing down and stopping the vehicle.

**Single axle set** means either one axle or two axles having their centres spaced less than 1 m apart.

**Supply line** means the part of a circuit that supplies energy in the form of compressed air or in any other suitable form from the towing vehicle to the towed vehicle.

**Suspension system** means a system that allows controlled and limited movement of an axle relative to the chassis or body of a vehicle; and includes a spring system and damping system and any associated controls.

**Tandem axle set** means an axle set comprising two axles having their centres spaced not less than 1 m and not more than 2 m apart.

**Technical standard** means a Japanese domestic vehicle standard issued by the Japanese Ministry of Land, Infrastructure and Transport and translated into, and published in, English by the Japan Automobile Standards Internationalization Center (JASIC) in the *Automobile Type Approval Handbook for Japanese Certification*.

**Threshold pressure for an axle of an air-braked vehicle**, means the pressure measured at the control line of the brake coupling when a braking effect on the axle begins.

**Towing connection** means the combination of components that enables one vehicle to tow or be towed by another vehicle; and includes a towbar, drawbar, drawbeam and coupling.

**Tractor** means a motor vehicle (other than a traction engine) constructed principally for towing an agricultural trailer or powering agricultural implements.

**Trailer** means a vehicle without motive power that is capable of being drawn or propelled by a motor vehicle from which it is readily detachable; but does not include:

- (a) a side-car attached to a motor cycle; or
- (b) a vehicle normally propelled by mechanical power while it is being temporarily towed without the use of its own power.

**Trailer brake hand control** means a hand-operated control capable of applying the service brake of the trailer or trailers.

**Transmission in relation to a motor vehicle**, means the gearing system and related components, including a driveshaft, by which power is transmitted from the flywheel or the engine output shaft to the input shafts of the powered axles.

**Tri-axle set** means a set of three axles, where:

- (a) the centres of the first and third axles are spaced not less than 2 m and not more than 3 m apart; and
- (b) all axles contain an equal number of tyres; and
- (c) none of the axles is a single standard-tyred axle.

**Twin-steer axle set** means a tandem axle set with single tyres, where both axles are connected to the same mechanism in order to steer similarly.

**UN/ECE** is an abbreviation for a regulation of the United Nations Economic Commission for Europe.

**Unladen mass** in relation to a vehicle, means the mass of the vehicle together with the fuel in its fuel system (if any) and the equipment and accessories on it that are necessary for its operation for the purpose for which it was designed.

**Vehicle** has the same meaning as in section 2(1) of the Land Transport Act 1998.

**[Vehicle identification number (VIN)** has the meaning as in Land Transport Rule: Vehicle Standards Compliance 2002.]

**Vehicle inspector or inspecting organisation** has the same meaning as in Land Transport Rule: Vehicle Standards Compliance 2002.

**Wheel** means a rotating load-carrying member between the tyre and the hub, which usually consists of two major parts, the rim and the wheel disc, which may be manufactured as one part, or permanently attached to each other, or detachable from each other; and includes the tyre fitted to the rim.

**Table A — Vehicle classes**

<b>Class</b>	<b>Description</b>
AA (Pedal cycle)	A vehicle designed to be propelled through a mechanism solely by human power.
AB (Power-assisted pedal cycle)	A pedal cycle to which is attached one or more auxiliary propulsion motors having a combined maximum power output not exceeding 200 watts.
LA (Moped with two wheels)	A motor vehicle (other than a power-assisted pedal cycle) that: <ul style="list-style-type: none"> <li>(a) has two wheels; and</li> <li>(b) either: <ul style="list-style-type: none"> <li>(i) has an engine cylinder capacity not exceeding 50 ml and a maximum speed not exceeding 50 km/h; or</li> <li>(ii) has a power source other than a piston engine and a maximum speed not exceeding 50 km/h.</li> </ul> </li> </ul>
LB (Moped with three wheels)	A motor vehicle (other than a power-assisted pedal cycle) that: <ul style="list-style-type: none"> <li>(a) has three wheels; and</li> <li>(b) either: <ul style="list-style-type: none"> <li>(i) has an engine cylinder capacity not exceeding 50 ml and a maximum speed not exceeding 50 km/h; or</li> <li>(ii) has a power source other than a piston engine and a maximum speed not exceeding 50 km/h.</li> </ul> </li> </ul>
LB 1	A Class LB motor vehicle that has one wheel at the front and two wheels at the rear.
LB 2	A Class LB motor vehicle that has two wheels at the front and one wheel at the rear.
LC (Motor cycle)	A motor vehicle that: <ul style="list-style-type: none"> <li>(a) has two wheels; and</li> <li>(b) either: <ul style="list-style-type: none"> <li>(i) has an engine cylinder capacity exceeding 50 ml; or</li> <li>(ii) has a maximum speed exceeding 50 km/h.</li> </ul> </li> </ul>

Class	Description
LD (Motor cycle and side-car)	A motor vehicle that: (a) has three wheels asymmetrically arranged in relation to the longitudinal median axis; and (b) either: (i) has an engine cylinder capacity exceeding 50 ml; or (ii) has a maximum speed exceeding 50 km/h.
Side-car	A car, box, or other receptacle attached to the side of a motor cycle and supported by a wheel.
LE (Motor tri-cycle)	A motor vehicle that: (a) has three wheels symmetrically arranged in relation to the longitudinal median axis; and (b) has a gross vehicle mass not exceeding one tonne; and (c) either: (i) has an engine cylinder capacity exceeding 50 ml; or (ii) has a maximum speed exceeding 50 km/h.
LE 1	A Class LE motor vehicle that has one wheel at the front and two wheels at the rear.
LE 2	A Class LE motor vehicle that has two wheels at the front and one wheel at the rear.
Passenger vehicle	A motor vehicle that: (a) is constructed primarily for the carriage of passengers; and (b) either: (i) has at least four wheels; or (ii) has three wheels and a gross vehicle mass exceeding one tonne.
MA (Passenger car)	A passenger vehicle (other than a Class MB or Class MC vehicle) that has not more than nine seating positions (including the driver's seating position).
MB (Forward control passenger vehicle)	A passenger vehicle (other than a Class MC vehicle): (a) that has not more than nine seating positions (including the drivers seating position); and (b) in which the centre of the steering wheel is in the forward quarter of the vehicle's total length.
MC (Off-road passenger vehicle)	A passenger vehicle, designed with special features for off-road operation, that has not more than nine seating positions (including the drivers seating position), and that: (a) has four-wheel drive; and (b) has at least four of the following characteristics when the vehicle is unladen on a level surface and the front wheels are parallel to the vehicle's longitudinal centre-line and the tyres are inflated to the vehicle manufacturers recommended pressure: (i) an approach angle of not less than 28 degrees; (ii) a breakover angle of not less than 14 degrees; (iii) a departure angle of not less than 20 degrees; (iv) a running clearance of not less than 200 mm; (v) a front axle clearance, rear axle clearance, or suspension clearance of not less than 175 mm.

<b>Class</b>	<b>Description</b>
Omnibus	A passenger vehicle that has more than nine seating positions (including the drivers seating position). An omnibus comprising two or more non-separable but articulated units shall be considered as a single vehicle.
MD (Light omnibus)	An omnibus that has a gross vehicle mass not exceeding 5 tonnes.
MD 1	An omnibus that has a gross vehicle mass not exceeding 3.5 tonnes and not more than 12 seats.
MD 2	An omnibus that has a gross vehicle mass not exceeding 3.5 tonnes and more than 12 seats.
MD 3	An omnibus that has a gross vehicle mass exceeding 3.5 tonnes but not exceeding 4.5 tonnes.
MD 4	An omnibus that has a gross vehicle mass exceeding 4.5 tonnes but not exceeding 5 tonnes.
ME (Heavy omnibus)	An omnibus that has a gross vehicle mass exceeding 5 tonnes.
Goods vehicle	A motor vehicle that: (a) is constructed primarily for the carriage of goods; and (b) either: (i) has at least four wheels; or (ii) has three wheels and a gross vehicle mass exceeding one tonne. For the purpose of this description: (a) a vehicle that is constructed for both the carriage of goods and passengers shall be considered primarily for the carriage of goods if the number of seating positions multiplied by 68 kg is less than 50% of the difference between the gross vehicle mass and the unladen mass; (b) the equipment and installations carried on special purpose vehicles not designed for the carriage of passengers shall be considered to be goods; (c) a goods vehicle that has two or more non-separable but articulated units shall be considered to be a single vehicle.
NA (Light goods vehicle)	A goods vehicle that has a gross vehicle mass not exceeding 3.5 tonnes.
NB (Medium goods vehicle)	A goods vehicle that has a gross vehicle mass exceeding 3.5 tonnes but not exceeding 12 tonnes.
NC (Heavy goods vehicle)	A goods vehicle that has a gross vehicle mass exceeding 12 tonnes.
Trailer	A vehicle without motive power that is constructed for the purpose of being drawn behind a motor vehicle.
TA (Very light trailer)	A single-axled trailer that has a gross vehicle mass not exceeding 0.75 tonnes.
TB (Light trailer)	A trailer (other than a Class TA trailer) that has a gross vehicle mass not exceeding 3.5 tonnes.
TC (Medium trailer)	A trailer that has a gross vehicle mass exceeding 3.5 tonnes but not exceeding 10 tonnes.
TD (Heavy trailer)	A trailer that has a gross vehicle mass exceeding 10 tonnes.

## Part 3 — Schedules

### Schedule 1

#### Interim Performance Specification for Heavy Vehicle Braking

(reg 1.0 to reg 9.0)

#### 1.0 Introduction

- 1.1 This Specification is the braking standard that combinations of vehicles must comply with.
- 1.2 Regulation 16(A), Paragraphs 1(a) and 6(d) of the Heavy Motor Vehicle Regulations 1974, require that all vehicle combinations, operating in excess of 39 tonnes GCM, shall comply with this Standard. This requirement is in addition to the normal Certificate of Fitness inspection. It does not replace the current statutory braking requirements.

- 1.3 A fee will be charged for this test which will be based on the time taken and the standard charge out rate for authorised vehicle inspectors and Police Officers.
- 2.0 Definitions**
- 2.1 **Authorised Vehicle Inspector(s)** means a person who is employed as a vehicle inspector by an authorised vehicle inspection organisation.
- 2.2 **Controlled** means the braking performance of the vehicle being tested during a prescribed brake application. Refer Cl. 6.4.
- 2.3 **50 km/hr** means between 49 and 51 km/hr according to the towing vehicles speedometer.
- 2.4 **Fully laden** means laden to the maximum permitted under the current size and weight limits.
- 2.5 **Full trailer** means a towed vehicle fitted with at least two axle set and equipped with a draw bar which controls the direction of the front axle(s) and which transmits no significant static load to the towing vehicle.
- 2.6 **GCM** means Gross Combination Mass, means the sum of the GVM's of the towing and towed trailer(s) used in a combination. It is the lesser of that specified by the manufacturer of the towing vehicle or the New Zealand regulations.
- 2.7 **GVM** means the maximum laden mass of a motor vehicle as specified by the manufacturer or the New Zealand regulations, whichever is the lesser.
- 2.8 **Identical** means having nominally identical:
- Structure (chassis, axle spacings, manufacturer, etc); and
  - Axles, suspensions, tyres; and
  - Foundation brakes (drum diameter, brake shoe width, lever length, chamber size, etc); and
  - Braking system (supply and control systems); and
  - Towing connections.
- 2.9 **Operator** means the owner, the operator, or the driver, as appropriate
- 2.10 **Satisfactorily** describes the braking performance of the vehicle under test that meets the performance specified in Cl. 6.5.
- 2.11 **Semi-trailer** means a towed vehicle having one axle set positioned behind the centre of gravity of the vehicle (when laden) so that a substantial portion of the laden weight is superimposed on the towing vehicle.
- 2.12 **Significant** means either violent or of long duration.
- 2.13 **Trailer** means a towed vehicle.
- 2.14 **Type Approval** means
- 2.15 **Using the service brakes only** means that the transmission must be in neutral or the clutch disengaged so that there is no retarding effect from either the engine itself or from any exhaust brake or other type of retarder.
- 3.0 Scope**
- 3.1 The requirements of this Specification shall apply to all vehicles which operate in any combination at a GCM exceeding 39 tonnes. This Specification applies only to those vehicles that have a GCM rating.
- 3.2 Any vehicle which will not be used in a combination at a GCM exceeding 39 tonnes will be deemed to comply with this Specification if it passes the requirements for a Certificate of Fitness. A vehicle inspector may, at his discretion, apply the criteria set out in Section 6 of this Specification as an aid to assessing compliance with the Certificate of Fitness requirements.
- 3.3 From 1 July 1994, this Specification shall only apply to those vehicles that are already in service. By 1 July 1995, this Specification will have been phased out and the Heavy Vehicle Brake Code will have become the sole acceptable braking standard for heavy goods service vehicles operating in combination, in excess of 39 tonnes.
- 3.4 Compliance of vehicles with this Specification will be specific. There will be no “type approval”. Vehicle combinations must be semi-dedicated and will be specified on the approval certificate. The test is to be applied to every specific vehicle and vehicle combination except as indicated below. For example a fleet of three trucks and three trailers may be proposed for use in any combination, but each combination must be specified, and the approval for each truck will list each trailer. Refer to Cl. 3.5.
- 3.5 Where identical trailers or semi-trailers are proposed for use with more than one truck or tractor, the testing of every combination will not be necessary provided that:
- (a) B-train semi-trailers are a dedicated pair, without exception.
  - (b) At least one trailer must be tested with every truck or tractor unit.
  - (c) Every trailer must be tested with at least one truck or tractor unit.
  - (d) Where a difference in performance between trailers is detected, then the trailer with the poorer performance (lower deceleration, greater deviation from the straight line of travel) shall either be used as the one trailer specified in (b) above, or shall be deleted as a proposed vehicle in combination.
  - (e) Similarly a truck or tractor with lower performance shall be used as the one truck or tractor specified in (c) above.
- 4.0 Equipment requirements**
- 4.1 Service brakes must operate on every axle.
- 4.2 In case of a service braking failure due to a loss of air or operating medium from any of the vehicles in a combination, each vehicle in the combination must either apply its brakes automatically, or leave the brakes under the control of the driver.
- 4.3 Every vehicle (including trailers and semi-trailers) must have an emergency braking system which is substantially independent of the service braking system, and which operates on at least half of the axles on each vehicle and is operable from one control within easy reach of the driver in his normal seating position. This emergency braking would generally operate by the force of the springs in spring brake chambers, but the inclusion of ordinary air chamber operation is not prohibited; e.g. a three-axle trailer with air on the front axle and spring brakes on the rear group of axles.
- 4.4 Every vehicle, including trailers and semi-trailers, must have a parking brake system substantially independent of service brakes which:
- (a) Operates on at least half of the axles on each vehicle; and
  - (b) Will hold the vehicle when fully laden on a 1 in 5 grade for an indefinite period; and

- (c) Is operable by the driver in his normal seating position.
- 4.5 All air connections between towing and towed vehicle shall be of the two-line type (excluding auxiliaries). Where air connections are physically capable of being incorrectly connected, they shall be colour Coded in the following manner:
- (a) Control (Service) lines shall be coloured either yellow, green or blue. The Supply (Emergency) lines shall be coloured red.
- (b) It is recommended that couplings that cannot be incorrectly connected are colour-Coded in the same way.
- 4.6 At the interface coupling (towing to towed vehicle), the service (control) line shall be on the left of the coupling, and the emergency (supply) line shall be to the right. Couplings shall be on the longitudinal centre-line of the vehicle, or close to it on the right-hand side. In each case, left and right correspond to a person facing in the direction of normal travel.
- 4.7 Every vehicle submitted for testing to this Specification must have travelled at least 500 km beforehand, with the vehicle braking equipment as fitted to the vehicle at the time of testing. The intention of this clause is to allow the brake system to “bed in”, especially the friction linings. If there is reasonable cause to suspect that this requirement has not been complied with, the vehicle shall be rejected.

#### 5.0 Prerequisites for carrying out the braking test

- 5.1 Every vehicle being tested for compliance with this Specification shall:
- Have a current certificate of fitness, and must be up to certificate of fitness standard. Towing connections must comply as follows:
  - Towing connections must comply as follows:
    - Full trailers: the current edition of NZS 5446; or
    - Semi-trailers: the current edition of NZS 5450/5451, as appropriate.
  - Load anchorage points must comply with the current edition of NZS 5444.
  - Loads must be attached in accordance with the Truck Loading Code.
  - Operator must complete data sheet for each submitted vehicle.
  - Operator must mark the outer sidewall of each tyre with four equi-spaced radial white lines approximately 100 mm wide, using acrylic paint or similar medium.
  - Each axle must be weighed before the test within a time specified by the vehicle inspector.
  - Axle loadings must not exceed the legal limits.
- 5.2 Operators are to be encouraged to carry out sufficient checking and/or testing beforehand, so that time is not wasted during the official tests.
- They are also to be reminded that any such testing must not endanger or inconvenience other road users, and that such testing should be carried out at lower speeds initially.

#### 6.0 Test requirements

- 6.1 Each combination of vehicles must satisfactorily perform three successive controlled emergency stops from 50 km/hr, when fully laden using only the service brakes. This is to ensure that one satisfactory stop is not a fluke and that some provision for fade is made.
- 6.2 The number of stops may be reduced by the vehicle inspector in the light of testing experience, e.g. when testing a group of “identical” combinations, if the first two stops with the second and subsequent combinations produce results effectively identical to the first combination, then the third test may be waived.
- 6.3 Where there is reason to doubt the accuracy of the speedometer, the instrument shall be calibrated to the satisfaction of the vehicle inspector.
- 6.4 During a satisfactory brake test brake application:
- Where lock up occurs in an axle group, at least one complete axle shall not lockup at any speed above 20 km/hr.
  - Every vehicle must stay wholly within the 3.7 m lane width. This point may be determined either by an observer, or by the use of traffic cones.
  - There must be no significant axle hop during the stop.
- 6.5 Each vehicle combination is deemed to have undergone a satisfactory brake test, if:
- No lockup of any axle occurs at speeds over 20 km/hr.
  - The combination remains with the 3.7 m lane during stopping.
  - No significant axle hop takes place.

and the braking performance equals or exceeds:

- For service brakes, the average deceleration rate shall be not less than 0.41g (41%) for at least two of the stops, and shall be not less 0.39g (39%) for the third stop.
- Using the emergency brakes, the average deceleration rate shall be not less than 0.25g (25%).
- Using only the emergency brake, perform one controlled stop from 50 km/hr when fully laden.

For the purposes of this clause, the stopping distances or times tabled in Appendix A to Section 2 of Chapter 2 in The Automotive Surveyors Manual may be used to determine average deceleration.

The load must not be disturbed by any significant amount.

#### 7.0 Conduct of the braking tests

- 7.1 The vehicle or vehicles must be presented by the operator at a time and place specified by the vehicle inspector. The test will be conducted with the operator driving, with one vehicle inspector in the cab, and one or more observing.
- 7.2 Alternative arrangements may be made by the vehicle inspector in charge of the testing, provided that the spirit and intent of this Specification is met.
- 7.3 The payload shall be distributed as evenly as possible over the load carrying portion of the vehicles. The axle loads shall be verified immediately before or after the test.
- In this context **immediately** need not be taken literally, provided that there is no opportunity for off-loading between weighing and test.

- 7.4 The tests shall be carried out on a flat straight sealed road (or equivalent surface) marked with lanes 3.7 m wide, and the vehicle shall be in the centre of the lane each time braking commences.  
Ideally the test site will be flat straight road of say 0.5 km, with a minimum of street furniture, and with ample flat or approximately flat run-off areas. The test must be conducted when there is little or no other traffic and there must be suitable turning areas, or roads forming a circuit. The test area must be near a weighbridge, or portable weighing equipment must be available.
- 7.5 Vehicle inspectors shall co-operate with Police Officers to ensure that the tests are carried out as smoothly as possible, and with no danger or inconvenience to other road users. Where necessary, the road should be closed to other traffic for the duration of the tests. Vehicle inspectors should liaise with police and local authorities.
- 7.6 Subsequent certificate of fitness inspections will verify that the details shown on the data sheet are still correct.

### 8.0 Required certification

- 8.1 For this Specification to be complied with, each vehicle within the combination shall have the following forms completed in full:
- MOT4076A; Heavy Motor Vehicle Size and Weight Limits, Data Sheet.
  - MOT4076B; Heavy Motor Vehicle Braking Specification, Test Results
  - MOT4011; Loading Certificate.
  - MOT4011A, Loading Certificate. Gross Combination Weight Exceeding 39 Tonne.
- The forms MOT 4011 and 4011A must be displayed on the vehicle at all times as it is these two forms that testify that a particular vehicle complies with this Specification. The white form (top copy) is to be given to the vehicle's operator and the yellow duplicate retained by the testing station.

### 9.0 Braking Specification as applied to new vehicles

- 9.1 Where a "new" vehicle is tested, the following additional requirements will apply:
- Power connections (air and electrical) on towing vehicles are to be installed by the vehicle's manufacturer or accredited agent.
  - Quick release air-line couplings are to be identified by the supplier as to their suitability, i.e. whether or not suitable for the front end of a semi-trailer.
  - Towing vehicles that have incorrect connections, or which cannot meet the recovery times when the rig is connected, will be refused a certificate of fitness.
  - Graduated hand controls for trailer brakes will not be permitted. Only trailer brake hand controls will only a permitted, if they are of the full-on or full-off type.

## Schedule 2

### Heavy Vehicle Braking Specification of 6 December 1988

(reg 00. to reg C.)

#### 00. Introduction

- A. This document is the operative version of the Specification. It has been developed from previous drafts dated 7 June and 11 August, and incorporates amendments as at the above date. This version will be used as part of the assessment of vehicles to be operated at the new size and weight limits. Amendments may be made in the light of operating experience, and comments should be submitted to the Chairman of the Braking Committee, Mr R A Lambert, PO Box 12843, Auckland, or to the Controller, Vehicle Standards, Land Transport Division, Ministry of Transport, Wellington.

#### B. Background

- (a) Some concern was expressed a few years ago about the standard of braking of heavy vehicles. A committee was formed to review the situation and to recommend appropriate existing Codes, or to prepare, if necessary, a Code for New Zealand. A draft Code has been prepared, which, when finalised will apply to all heavy vehicles.
- (b) The review of size and weight limits for heavy vehicles was deemed to be appropriate only if a number of safety features (including braking) were improved.
- (c) Opinions vary as to which of the foregoing came first, but it is a fact that the implementation of new size and weight limits became closely linked with, and dependent on, the completion of a New Zealand Heavy Vehicle Braking Code.
- (d) Because of the complexity of the subject, and financial constraints, the Code has progressed more slowly than had been expected. During that time there has been an increasing expectation from the transport industry that the new size and weight limits were imminent. These two factors have resulted in pressure being applied to the Braking Committee to finalise the Code. The Committee believes that more investigation and testing is necessary before the Code can be finalised, and that if it were published in its present, unfinished, state, there could be implementation problems which might lead to the Code falling into disrepute.
- (e) The Ministry of Transport agrees that the introduction of a sound and workable Braking Code is too important to risk jeopardising by premature publication. Therefore introduction of the new size and weight limits is no longer dependent on the full Code, as such, but this Specification may be seen as a first step towards it.
- (f) This Specification is an additional requirement for vehicle combinations exceeding 39 tonnes, and it does not replace the current braking requirements. Those will remain part of the normal certificate of fitness inspection.

#### 1. Scope and limitations

- A. This Specification applies only to vehicles which will be used in any combination at a GCM exceeding 39 tonnes.
- B. In this Specification **operator** may mean the owner, the operator, or the driver, as appropriate.
- C. Approval of vehicles to this Code will be specific, ie will not be a "type approval". Vehicle combinations must be semi-dedicated and will be specified on the approval. The test is to be applied to every specific vehicle and vehicle combination except as indicated below. For example a fleet of three trucks and three trailers may be proposed for use in any combination, but each combination must be specified, and the approval for each truck will list each trailer.

- D. Where identical trailers or semi-trailers are proposed for use with more than one truck or tractor, the testing of every combination will not be necessary provided that:
- (a) B-train semi-trailers are a dedicated pair, without exception
  - (b) at least one trailer must be tested with every truck or tractor
  - (c) every trailer must be tested with at least one truck or tractor
  - (d) where a difference in performance between trailers is detected, then the trailer with the poorer performance (lower deceleration, greater deviation from straight) shall either be used as the one trailer specified in (a) or shall be deleted as a proposed vehicle in combination
  - (e) similarly a truck or tractor with lower performance shall be used as the one truck or tractor specified in (b)
  - (f) **identical** means having nominally identical
    - (1) structure (chassis, axle spacings, manufacturer, etc)
    - (2) axles, suspensions, tyres
    - (3) foundation brakes (drum dia and width, lever length, chamber size, etc)
    - (4) braking system (supply and control systems)
    - (5) towing connections.

## 2. Equipment requirements

- A. Service brakes must operate on every axle.
- B. In case of braking failure in any of the vehicles in a combination, each vehicle in the combination must either apply its brakes automatically, or leave the brakes under the control of the driver.
- C. Every vehicle (including trailers and semi-trailers) must have an emergency braking system which is substantially independent of the service braking system, and which operates on at least half of the axles on each vehicle, and which is operable from one control within easy reach of the driver in his normal seating position. This emergency braking would generally operate by the force of the springs in spring brake chambers, but the inclusion of ordinary air chamber operation is not prohibited; e.g. a three-axle trailer with air on the front axle and spring brakes on the rear bogie.
- D. Every vehicle (including trailers and semi-trailers) must have a parking brake system substantially independent of the service brakes, and which:
- (a) operates on at least half of the axles on each vehicle; and
  - (b) will hold the vehicle when fully laden on a 1 in 5 grade for an indefinite period; and
  - (c) is operable by the driver in his normal seating position.
- E. All air connections between towing and towed vehicle shall be of the two-line type (excluding auxiliaries).
- F. Air-line identification
- (a) Connections that are physically capable of being incorrectly connected shall be colour-Coded thus: control line = yellow, green or blue; supply line = red.
  - (b) It is recommended that couplings that cannot be incorrectly connected are colour-Coded in the same way.
- G. Couplings
- (a) At the interface coupling (towing to towed vehicle), the service (control) line shall be to the left of the vehicle, and the emergency (supply) line shall be to the right.
  - (b) Couplings shall be on the longitudinal centre-line of the vehicle, or close to it on the right-hand side.
  - (c) In each case, left and right correspond to a person facing in the direction of normal travel.
- H. Every vehicle submitted for testing to this Specification must have travelled at least 500 km beforehand, with the vehicle braking equipment as fitted to the vehicle at the time of testing. The intention of this clause is to allow the brake system to “bed in”, especially the friction linings. If there is reasonable cause to suspect that this requirement has not been complied with, the vehicle shall be rejected.

## 3. Pre-conditions for test

- A. Each vehicle must have a current certificate of fitness, and must be up to certificate of fitness standard.
- B. Towing connections must comply with NZS 5446 (full trailers) or NZS 5450/5451 (semi-trailers) as appropriate.
- C. Load anchorage points must comply with NZS 5444
- D. Note that under (B) and (C) above, compliance with drafts current at the time will be deemed acceptable.
- E. Loads must be attached in accordance with the Truck Loading Code.
- F. Operator must complete data sheet for each submitted vehicle.
- G. Operator must mark the outer sidewall of each tyre with four equi-spaced radial white lines approx 100 mm wide, using acrylic paint or similar medium.
- H. Each axle must be weighed before the test within a time specified by the Auto Surveyor.
- I. Axle loadings must not exceed those to be permitted under new size and weight limits.

## 4. Test requirements

- A. Each combination of vehicles must satisfactorily perform three successive controlled emergency stops from 50 km/hr when fully laden, using the service brakes only.
- (a) This requirement is to ensure that one satisfactory stop is not a fluke; and also makes some provision for fade.
  - (b) The number of stops may be reduced by the automotive surveyor in the light of testing experience, e.g. when testing a group of “identical” combinations, if the first two stops with the second and subsequent combinations produce results effectively identical to the first combination, then the third test may be waived.
- B. Each combination of vehicles must also satisfactorily perform one controlled stop from 50 km/hr when fully laden, using the emergency brakes only.

- C. The tests shall be carried out on a flat straight sealed road (or equivalent surface) marked with lanes 3.7 m wide, and the vehicle shall be in the centre of the lane each time braking commences.
- D. **Fully laden** means laden to the maximum permitted under the new size and weight limits, with the payload distributed as evenly as possible along (or in) the load carrying portion of the vehicles. The axle loads shall be verified immediately before or after the test. In this context **immediately** need not be taken literally, provided that there is no opportunity for off-loading between weighing and test.
- E. **50 km/hr** means between 49 and 51 km/hr according to the towing vehicles speedometer unless there is reason to doubt the accuracy of that instrument, in which case calibration shall be arranged to the satisfaction of the Automotive Surveyor or Traffic Officer.
- F. **Controlled** means:
- in any axle group in which lockup occurs, at least one complete axle shall not lockup at any speed above 20 km/hr;
  - every vehicle must stay wholly within the 3.7 m lane width. This point may be determined either by an observer, or by the use of traffic cones.
  - there must be no significant axle hop during the stop. In this context **significant** means either violent or of long duration.
- G. **Satisfactorily** means that:
- using the service brakes, the average deceleration rate shall be not less than 0.41g (41%) for at least two of the stops, and shall be not less 0.39g (39%) for the third stop;
  - using the emergency brakes, the average deceleration rate shall be not less than 0.25g (25%);
  - for the purposes of this clause, the stopping distances or times tabled in Appendix A to Section 2 of Chapter 2 in The Automotive Surveyors Manual may be used to determine average deceleration.
  - The load must not be disturbed by any significant amount
- H. **Using the service brakes only** means that the transmission must be in neutral or the clutch disengaged so that there is no retarding effect from either the engine itself or from any exhaust brake or other type of retarder.
5. The vehicle or vehicles must be presented by the operator at a time and place specified by the Automotive Surveyor. The test will be conducted with the operator driving, one Automotive Surveyor in the cab, and one or more Automotive Surveyors observing.
- A. Alternative arrangements may be made by the Automotive Surveyor in charge of the testing, provided that the spirit and intent of the Specification is met.
6. Ideally the test site will be flat straight road of say 0.5 km, with minimum street furniture, and with ample flat or approximately flat run-off areas. The test must be conducted when there is little or no other traffic and there must be suitable turning areas, or roads forming a circuit. The test area must be near a weighbridge, or portable weighing equipment must be available.
7. Automotive Surveyors and Traffic Officers will co-operate to ensure that the tests may be carried out as smoothly as possible, and with no danger or inconvenience to other road users. If necessary, the road will be closed to other traffic for the duration of the tests.
8. The test described in this Specification is in addition to the normal certificate of fitness inspection. A fee will be charged based on the time taken, at the standard charge-out rate for Automotive Surveyors and Traffic Officers.
9. Subsequent certificate of fitness inspections will verify that the details shown on the data sheet are still correct.
10. Operators are to be recommended to carry out sufficient checking and/or testing beforehand, so that time is not wasted during the official tests. Operators are to be reminded that any such testing must not endanger or inconvenience other road users, and that such testing should be carried out at lower speeds initially. Any such advice must include the warning that the current weight limits still apply.

#### 11. Future requirements

- A. It is likely that this Code will be applied only to existing vehicles. In the event that a “new” vehicle is tested, the following additional requirements will apply (these will either be part of the final brake Code or subject to new Regulations).
- Power connections (air and electrical) on towing vehicles are to be installed by the vehicle manufacturer or accredited agent. This may become a general requirement for every vehicle which is sold as being capable of towing, i.e. has a towing rating.
  - Quick release air-line couplings are to be identified by the supplier as to their suitability i.e., whether or not suitable for the front end of a semi-trailer.
  - Development is presently underway on a test rig to check towing vehicle air connections. This will, in due course become part of the certificate of fitness inspection. Towing vehicles that have incorrect connections, or which cannot meet the recovery times when the rig is connected, will be refused a certificate of fitness.
  - It is possible that a requirement may be introduced for graduated brakes (service brakes) to operate from one control only, e.g. separate graduated hand controls for trailer brakes will not be permitted.
- In such a case, trailer brake hand controls will only be permitted, if they are of the full-on or full-off type.

#### *Vehicle Standards Bulletin – Excerpt November 29, 1988*

- A. 44 tonne assessment and brake test - Errata
- Instructions to Automotive Surveyors
    - Page 2, item C.8.e) – should read “DZ 5444 or NZS 5444”
    - Page 2, item C.8.h) – should read “Check that truck wheelbase is not less than 4250 mm”  
Effectively only applicable to 6×4 trucks and drawbar trailers
    - Page 2, item C.8.j.)T) – should read “Tyres and Rims”
    - Other minor typographical errors should be readily detectable by the discerning reader.
  - Instructions to Operators

- (a) Page 1, item B.1.a – add “Except that interim permits may be obtained from MoT Head Office, applications should be marked for Traffic Engineering”
- (b) Page 1, item B.1.e.iv – add “for all combinations over 39 tonnes and all A-trains over 19 metres”.
- 3. Heavy Vehicle Braking Specification
  - (a) Page 3, item 2.D – add “and which must hold the vehicle for an indefinite period on a gradient of 1 in 5”. Note that the parking brake is required to be substantially independent of the service brakes, but can be combined with the emergency brakes.
  - (b) Page 3, item 2.G.a – should read “service (control) line shall be to the LEFT emergency (supply) line shall be to the RIGHT”.
- 4. Data Sheet - MOT 4076A
  - (a) Wheel base (Minimum 4250 mm) effectively pertains only to 6×4 truck.
- 5. Loading Certificate – MOT 4011A
  - (a) Under “Permitted Combinations” the right-hand side is intended for recording the second semi-trailer of a B-train. The two semi-trailers of each B-train assessed should be recorded on the same line. If the combination is not a B-train, the right-hand side should be crossed, and any rows of the left-hand side that are not filled in should also be crossed, or otherwise rendered unuseable.

R L Reynolds

Controller, Vehicle Standards

*Assessment for New Size and Weight Limits December 6, 1988*

**A.** If you have a vehicle or combination of vehicles that you wish to operate at the new size and weight limits

- 1. Please read these notes carefully.
- 2. Obtain copies of the documents described.
- 3. Ensure that your vehicle or combination complies with the pre-conditions on or before the stated dates.
- 4. If you want a combination to operate in excess of 39 tonnes, follow the directions given in (C) below.

**B.** The package for the new size and weight limits has the following features:

- 1. No changes will take place until EVERY part of the package is complied with:
  - (a) The Traffic Regulations Amendment must be finalised and gazetted, to authorise the new dimensions, except that interim permits are available from MoT Head Office; applications should be marked for Traffic Engineering.
  - (b) The Heavy Motor Vehicle Regulations must be finalised and gazetted to authorise the new weight limits.
  - (c) Individual vehicles and/or combinations must comply with the dimension requirements.
  - (d) Individual vehicle, axle, and tyre ratings must be not less than the proposed loadings. Note that tyre, axle, and GVM and GCM ratings for all vehicles operating at the new size and weight limits:
    - (I) Must be verified by Head Office unless already in the Chassis Rating Book.
    - (II) Must be not more than the manufacturer's rating, unless uprated under the relevant criteria in the modification policy.
    - (III) May NOT include the 25% allowance on GVM or GCM.
  - (e) The published pre-conditions must be met by each vehicle or combination (for timing see B2 to B6 below)
    - (I) drawbars/drawbeams to NZS 5446
    - (II) fifth wheels/kingpins to NZS 5450/5451
    - (III) load anchorage points to NZS 5444
    - (IV) tandem drive on tractor or trucks for all combinations over 39 tonnes and all A-trains over 19 metres long
    - (V) load sharing suspensions
    - (VI) uniform suspension medium within axle groups
    - (VII) new braking requirements.
  - (f) New Zealand Standards (NZS) may be obtained from Standards Association of New Zealand, Private Bag, Wellington. The fifth wheel, king pin, and load anchorage standards

are, at the time of writing, still only in draft form. However, compliance with them in that form is deemed acceptable.

- (g) New braking requirements will be:
  - (I) immediately for 39+ tonnes, is by compliance with the Heavy Vehicle Braking Specification, available from MoT
  - (II) in due course for all vehicles, will be by compliance with a Braking Code that is still being developed.

2. All new vehicles will be required to comply with the new dimension limits and the pre-conditions listed above. For practical purposes this will be interpreted as:
  - (a) all vehicles first registered on or after 1 January 1989 will be expected to comply not later than 1 June 1989;
  - (b) all vehicles first registered on or after 1 June 1989 will be expected to comply immediately.
3. All existing vehicles which are intended to take advantage of the new weight limits must also comply with the new dimensions. Existing vehicles that do not comply, may continue to be operated at the old limits.
4. All existing vehicles will be expected to comply with drawbar/drawbeam standard by 1 January 1989.
5. All existing vehicles will be expected to comply with fifth wheel/kingpin, and load anchorage point standards within a reasonable time (proposed 1 June 1990).
6. All vehicle combinations to be operated in excess of 39 tonnes must be assessed and tested for compliance.

### C.

Combinations to exceed 39 tonnes.

1. Obtain from SANZ, as appropriate:
  - (a) NZS 5446
  - (b) NZS 5450 or DZ 5450
  - (c) NZS 5451 or DZ 5451
  - (d) NZS 5444 or DZ 5444.
2. Obtain from a MoT Vehicle Testing Station
  - (a) Heavy Vehicle Braking Specification
  - (b) Vehicle Data Sheet, (MOT 4076A) (original and carbon) for each vehicle.
3. Check that each vehicle complies with the items listed in (B1e), and that the braking performance complies with the Specification.
4. Fill in the Data Sheet as far as you are able, and present it with any outstanding certificates and assessment fee (\$200) to the Testing Station.
5. Arrange an appointment with the testing station manager for the assessment. Note that this may have to be in a regional centre rather than locally.
6. Turn up for the appointment:
  - (a) on time
  - (b) with every tyre painted with four white radial stripes 100 mm wide
  - (c) with the combination loaded as close to the new maximum limit as possible, in accordance with the truck loading Code.

Note that the load should be typical of that normally carried (e.g. logs on a logging trailer) except that the load should not be livestock, even if the combination is normally used for carrying livestock.

7. The assessment fee is for cost-recovery, therefore a broken appointment will mean that the fee is forfeit.

R L Reynolds

Senior Automotive Engineer

*LAND TRANSPORT A Division of the Ministry of Transport*

#### **Amendment to the HEAVY VEHICLE BRAKING SPECIFICATION**

The format and complexity of the equipment requirements in the HMV Regulations has meant that the most convenient way to treat braking is to amend the Braking Specification.

Delete Sub-Clause 1A and substitute the following:

#### 1. Scope and Limitations

- A. (I) All requirements of this Specification shall apply to all vehicles which will be used in any combination at a GCM exceeding 39 tonnes: except that the Controller of Vehicle Standards may approve the use of an alternative Code or Specification on specified vehicles for evaluation purposes.

- (II) Any vehicle which will not be used in a combination at a GCM exceeding 39 tonnes will be deemed to comply with this Specification if it passes the requirements for a Certificate of Fitness; except that an Automotive Surveyor may, at his discretion, apply the criteria set out in Part 4 of this Specification as an aid to assessing compliance with the Certificate of Fitness requirements.
- (III) This Specification will be automatically superseded when the Secretary for Transport approves the Heavy Vehicle Braking Code (by whatever name it is finally known) currently under development by the Heavy Vehicle Braking Committee. The final Code may contain requirements for existing vehicles. All existing vehicles will be expected to comply with any such requirements, whether or not they have been tested in accordance with this Specification.

R L Reynolds  
Controller Vehicle Standards  
3475/29E9/0116h  
PEARSE HOUSE 225 WILLIS STREET P.O. BOX 27459  
WELLINGTON NEW ZEALAND  
TELEPHONE (04) 828-300 FAX (04) 855-699, 855-799

### **Schedule 3** **Heavy Vehicle Brake Code, First edition 1991**

(reg 2.1 to reg 3.0)

Vehicle standards  
Land Transport Division  
Ministry of Transport  
ISBN 0-477 05252-5

#### *Acknowledgement*

The Ministry of Transport gratefully acknowledges the very substantial contributions made by the Chairman and members of the Heavy Vehicle Brake Code Committee, individually and collectively, in the preparation of this Code and for the support given to committee members by their respective employers.

The Ministry is also indebted to the various organisations that have made vehicles, equipment and services available and without whose support, the production of this Code would not have been possible.

© 1991 Land Transport Division

Ministry of Transport  
P O Box 27-459  
Wellington  
New Zealand  
Phone (04) 828-300 Fax (04) 855-699

#### *Contents*

##### Preface

- 1.0 Scope and interpretation
- 2.0 Definitions
- 3.0 Compliance
- 4.0 Specifications
- 5.0 Exemptions for power driven vehicles which are equipped to tow trailers

##### Appendices

- A Distribution of braking among the axles of vehicles and requirements for compatibility between drawing vehicle and trailer.
- B Requirements for measuring the response time on vehicles equipped with compressed-air brakes.
- C Statement of compliance with the New Zealand Heavy Vehicle Braking Code.
- D Pressure test connections for air-braking systems.
- E Maximum axle weights
- F Provisions relating to energy sources and energy storage devices.

#### *Preface*

##### Background to the New Zealand situation

In New Zealand, power driven vehicles are sourced from world markets, the majority coming from Europe, North America, Japan and Australia. The result is that the local powered vehicle population has variations of the braking systems common to the country of origin. Locally manufactured trailers generally use imported brake components and are only required to meet emergency stop and parking performances.

By legislation, New Zealand has lower individual axle loadings than are common in the countries from which the power driven vehicles and trailer components are sourced. The road tax on heavy vehicles is collected through a system known as Road User Charges and applies to vehicles over 3500 kg gross weight. It is allocated according to gross vehicle mass, axle configuration and distance travelled. This tax has created a situation unique to this country by encouraging operators to fit more axles to carry a given load than would otherwise be necessary. Braking problems therefore can arise because the axles used on these vehicles are designed for substantially higher loadings and are fitted with brakes sized accordingly.

#### The Code

This Code has been developed to improve the braking performance of heavy vehicles in New Zealand by an industry based committee consisting of representatives from the MVMA, NZRTA, IRTENZ, DSIR, NZTTMF and MOT. The Code is based on European brake performance requirements, namely the United Nation Economic Commission of Europe Regulation 13, (ECE 13). To facilitate its adoption into the brake Code, some simplifications to the regulation have been made and special New Zealand requirements have been included. Every effort has been made to minimise the extent of modifications necessary or existing vehicles to meet the Code requirements.

It is intended to Gazette this Code as an acceptable alternative (under Regulation I6A(2) of the Heavy Motor Vehicle Regulations 1974) to the current Heavy Vehicle Braking Specification, effective from 1 July 1991, for vehicle combinations operating at more than 39 000 kg. The further intention, is that all vehicles with a gross mass exceeding 3500 kg, first registered after 1 July 1994, will have to comply with ECE 13 plus special New Zealand annexes; or an equivalent international regulation if developed in the meantime. As a minimum requirement, any vehicle used in combination with a new vehicle first registered after 1 July 1994, shall comply with this Code.

#### Aims of the Code

The aim of this Code is to improve heavy vehicle safety by standardising braking performance. Its provisions can be summarised as follows:

- To ensure that certified individual vehicles in the fully laden state meet the required braking performance, at all levels of braking and axle loads permitted under the Heavy Motor Vehicle Regulations 1974.
- To ensure the continuing compliance of certified vehicles to this Code. This is the responsibility of the operator. It is essential that adequate records of work carried out, and components used on a vehicle are being kept.
- To improve compatibility between powered vehicles and trailers to ensure that vehicles in a combination function in harmony, provide optimum brake performance and improve directional stability. The majority of brake applications are at low levels of braking, well before the limits of adhesion are reached. The braking performance at or slightly above the threshold levels is a very important factor in ensuring brake compatibility.
- To introduce a brake control system with common characteristics on all vehicles. This ensures protection of individual vehicles, efficient emergency braking and safe parking of individual vehicles and vehicle combination.

#### Auxiliary brake equipment

The Code sets out general guide lines for supplementary brake equipment that gives the driver greater control and improved brake performance. This equipment includes such items as, trailer hand control, anti-lock braking systems (ABS), load sensing devices and engine retarders. The addition of any of this equipment to a certified vehicle will be classed as a modification and will require the vehicle to be recertified.

### 1.0

#### *Scope and interpretation*

This Code applies to the braking of vehicles with a gross vehicle mass of more than 3500 kg. It applies to power driven vehicles individually and to trailers individually.

In this Code the words “shall” or “must” indicate a requirement that is to be adopted in order to comply with the Code, while the word “should” indicates a recommended practice.

### 2.0

#### *Definitions*

#### **2.1 General**

2.1.1 **Certifier** means manufacturer, a group or a person who are recognised by the Statutory Authority as being experienced in the matter of Heavy Vehicle Braking.

2.1.2 **Drawing vehicle** means a vehicle equipped to tow a trailer.

2.1.3 **Gross Vehicle Mass (GVM)** means the maximum laden mass of a motor vehicle as specified by the manufacturer or the New Zealand regulations, whichever is the lesser. See Appendix E.

2.1.4 **Gross Combination Mass (GCM)** means the sum of the GVMs of the drawing vehicle and trailers) used in a combination. It is the lesser of that specified by the manufacturer of the drawing vehicle or the New Zealand regulations.

- 2.1.5 **Manufacturer** means an organisation acceptable to the Statutory Authority, engaged in the manufacture, assembly, or importation of vehicles with a GVM of more than 3500kg.
- 2.1.6 **Statutory authority** means the Secretary for Transport or persons with authority duly delegated by the Secretary for the purposes of this Code.
- 2.1.7 **Vehicle type** means a category of vehicles which do not differ in such essential respects as:
- The vehicle category (e.g. passenger vehicle or goods vehicle, power-driven vehicle or trailer).
  - The gross vehicle mass (as defined above).
  - The distribution of mass among the axles.
  - The type of brake system.
  - The number, relative position and arrangement of the axles and suspension types.
  - The effective tyre radius. Tyre radii of within 5% of the indicated tyre radius shall be held to be the same for the purposes of this Code
- 2.1.8 **Unladen mass** means the mass of the vehicle fitted with body and equipment, plus full fuel tanks.
- 2.2 Trailer definitions**
- 2.2.1 **Trailer** means a towed vehicle.
- 2.2.2 **Full trailer** means a towed vehicle fitted with at least two axle sets, and equipped with a drawbar which controls the direction of the front axle(s) and which transmits no significant static load to the drawing vehicle.
- 2.2.3 **Semi-trailer** means a towed vehicle having one axle set positioned behind the centre of gravity of the vehicle (when fully laden) so that a substantial portion of the laden vehicle's weight is superimposed on the drawing vehicle.
- 2.2.4 **Centre axle (simple) trailer** means a towed vehicle (not being a full trailer or semi-trailer) equipped with a drawbar such that only a small static vertical load is transmitted to the drawing vehicle when uniformly loaded.
- 2.3 Brake terminology**
- 2.3.1 **Air brake system** means a system in which the brake requires the use of compressed air.
- 2.3.2 **Brake** means the assembly in which the forces due to friction opposing the movement of the vehicle develop.
- 2.3.3 **Brake coupling (Coupling Head)** means the device for connecting the control and supply lines of the drawing vehicle to the control and supply lines of the trailer.
- 2.3.4 **Brake system** means the combination of parts whose function is to progressively reduce the speed of a moving vehicle or bring it to a halt, or keep it stationary if it is already halted. The system consists of the control, the circuit and the foundation brake.
- 2.3.5 **Circuit** means the combination of components between the control and the brake and linking them functionally. The circuit may be mechanical, hydraulic, pneumatic, electrical or mixed. Where the braking power is derived from or assisted by a source of energy independent of the driver but controlled by him, the reserve of energy in the device is likewise part of the circuit.
- 2.3.6 **Control** means the part actuated directly by the driver to furnish to the circuit the energy required for braking or controlling it. This energy may be the muscular energy of the driver, or energy from another source controlled by the driver.
- 2.3.7 **Control (Service) line** means the part of circuit along which the service brake signal is transmitted.
- 2.3.8 **Emergency braking** - see 4.1.2
- 2.3.9 **Graduated braking** means braking which, whether during application or release of the brakes, the driver can at any moment increase or decrease the braking force by acting on the control; and  
If the control is actuated by the foot, or used for control of brake other than park brake the control must return to the "off" position when released; and
- the braking force varies proportionally to the action of the control; and
  - the braking force can easily be regulated with sufficient precision.
- 2.3.10 **Load Sensing Device** means a device fitted to the brake system to regulate the braking effort on any axle(s) in proportion to the load carried by the axle(s). (See section 4.1.4 and Annex A7).
- 2.3.11 **Parking braking** - see 4.1.3
- 2.3.12 **Service braking** - see 4.1.1
- 2.3.13 **Supply (Emergency) line** means the path by which any stored energy required to actuate the brakes is supplied.
- 2.3.14 **Spring brake** means a brake in which the energy required for braking is supplied by one or more springs acting as an energy storage device.
- 2.3.15 **Trailer hand control** means a hand operated control capable of applying a graduated service braking action on the towed trailer(s) only
- 2.3.16 **Threshold pressure.** See Appendix A, A8.

### 3.0

#### *Compliance*

#### **3.1 Initial compliance**

Initial compliance with this Code is the responsibility of the Certifier.

- 3.1.1 The Certifier shall provide the Statutory Authority on request with one copy of the statement of compliance for every vehicle type (with format as shown in Appendix C).
- 3.1.2 The Certifier shall supply, with every vehicle complying with this Code, one copy of the statement of compliance (Appendix C). The operator of the vehicle shall be responsible for ensuring that the statement of compliance remains with the vehicle documentation, but not necessarily on the vehicle.
- 3.1.3 The Certifier will be responsible for the safe keeping of all the calculations, test reports and other documentation for each vehicle issued with a statement of compliance and also for making copies of such material available to the Statutory Authority on request. This material must include:
- (a) A set of calculations which shall demonstrate compliance as follows:
    - Service brake performance (Appendix A).
    - Emergency brake performance (clause 4.1.2).
    - Parking brake performance, only on vehicles with spring brakes fitted to more than half of the axles.
  - (b) A test report demonstrating compliance with the following requirements
    - Parking brake performance (clause 4.1.3), unless determined by calculation as above.
    - Energy sources and energy storage devices (Appendix F, Paragraph 2), or Current New Zealand Compressor Requirements.
    - Response time (Appendix B).
    - Brake torque reaction Test (Appendix A3.3.2(e)).
    - Load Sensing Valve operation (Appendix A7).
  - (c) The documentation shall also include a schematic Diagram of the brake circuit including a list of the components in the braking system. Also, a plate shall be affixed to the vehicle, adjacent to the vehicle's identification plate stating that this vehicle complies with NZHVBC, dated \_\_\_\_\_
- 3.1.4 If a Certifier ceases his involvement with design certification to this Code, the above mentioned records shall be forwarded to another practising Certifier and the Statutory Authority shall be notified of this change.

### 3.2 Continued compliance

Continued compliance with the Code is a responsibility of the vehicle operator.

#### 3.2.1 Servicing the brake system:

- (a) Companies or individuals who service brake systems on any vehicle complying with this Code are responsible for ensuring that work procedures and practices acceptable to the Certifier are followed. Full and detailed records must be kept of the work undertaken and of the parts supplied and installed. A copy of this information must be made available to a vehicle operator.
- (b) Only components which do not alter the performance and quality as originally specified by the Certifier shall be used when servicing the brake system. Replacement brake linings must be supplied with a compliance certificate in accordance with the details on the certificate of compliance and fitted in axle sets (See 4.1.5 and Appendix C).

#### 3.2.2 Modifications to the vehicle or the brake system

- (a) For every modification of the vehicle type or of its braking system, continued compliance with this Code shall be ensured by a Certifier.
- (b) The Certifier must provide the Statutory Authority with the full details of the modification and complete the modification certificate (see Appendix C). A copy of this modification certificate shall remain with the vehicle records.
- (c) Where the modification is appropriate to all vehicles of a particular vehicle type, the Certifier may issue a certificate to this effect, which clearly defines the modification and the vehicles for which it is appropriate.
- (d) If major modifications are made affecting the vehicle type or the brake system the Certifier shall issue a new Statement of Compliance (see Appendix C).

## 4.0

### *Specifications*

#### 4.1 Requirements of the brake system

The brake system as defined in 2.3.4 must fulfil the following functions:

- 4.1.1 The service braking must make it possible to control the movement and retardation of the vehicle or vehicles in combination. It must be possible to graduate this braking action. The driver must be able to achieve this braking action from the driving seat without removing his hands from the steering control.
- Service braking shall meet the requirements of Appendix A (Braking distribution) and should meet the requirements of Appendix B (Time response) of this Code. Service braking must be capable of stopping the fully laden vehicle within 7 metres from 30 kilometres per hour (equivalent to an average deceleration of 5 m/s<sup>2</sup>).
- The service braking must act on all wheels of the vehicle.
- 4.1.2 The emergency braking must be capable of stopping the fully laden vehicle or vehicle combination within 18m from 30 km/hr (equivalent to an average deceleration of 2 m/s<sup>2</sup>) in the event of failure of the service braking. The driver must be able

to achieve this braking action from the driving seat while keeping at least one hand on the steering control. For the purposes of these provisions it is assumed that not more than one failure of the service brake system will occur at one time.

- 4.1.3 The parking braking must be capable of holding the fully laden vehicle on an up or down gradient of 20% on a surface sealed to highway standard. The working parts must be held in the locked position by a purely mechanical device. From the driving seat, the driver must be able to achieve this braking action on the vehicle and any vehicle that it is designed to tow, subject, in the case of a trailer to the provisions of 4.4.2 below.
- 4.1.4 Wear on the brakes must be capable of being easily taken up by means of either a system of manual or automatic adjustment. In addition, the control and the components of the circuit and of the brakes must possess a reserve of travel such that, when the brakes become heated or the brake linings have reached a certain degree of wear, effective braking is ensured without immediate adjustment being necessary.
- 4.1.5 All components and devices in the brake system (including hoses and air connections) shall comply with at least one appropriate and recognised international, national or association standard where such standards exist. Recognised can be taken as meaning SAA, SAE, BS, JIS, ECE EEC, ISO, and DIN standards, in addition to other standards recognised by the statutory authority.
- Friction materials shall comply with one of the following:
- (a) ECE 13 Annex 4 (EEC 71/320 Annex 2) - Braking Tests and Performance; or, ECE 13 Annex 15 Inertia dynamotor test method for brake lining.
- (b) Friction material performance may be determined by one of the following tests providing that, when the vehicle is loaded to the gross vehicle mass (the maximum legally permitted in New Zealand), the retardation force versus control line pressure meet the requirements of this Code (Appendix A, Diagrams 2 and 3) prior to the test being conducted. Acceptable tests include:
- SAE J667, Brake Test Code - Inertia Dynamotor.
  - SAE J786a, Brake System Road Test Code - Truck, Bus and Combination Vehicles.
  - ADR 35A, Commercial Vehicle Brake systems (applicable to power driven vehicles only).
- (c) The friction material shall maintain stable friction characteristics between 100°C and 315°C and between 30 km/hour and 100 km/hour. **Stable** means that the friction coefficient does not vary above or below the nominated friction value by more than 0.025.
- 4.1.6 Vehicles fitted with load sensing devices shall only be used in combination with other vehicles also fitted with load sensing devices, however power driven vehicles and full trailers with a load sensing device fitted only to the rear axle set may be used in combination with vehicles without load sensing devices.
- 4.1.7 Vehicles to which anti-lock brake systems are fitted must comply with all the requirements of this Code.
- 4.1.8 Traction control systems may utilise the brake system components provided the system is fail-safe and does not interfere with normal braking.

## 4.2 Air brake system

- 4.2.1 A pressure test connection complying with the dimensional requirements of Appendix D shall be fitted at the intake to the chamber of the least favourably placed brake chamber (or pneumatic device in the case of partly pneumatic brake systems) with respect to brake timing (Appendix B) on each independent circuit of the braking system. See also Appendix F, clause 3.0.
- 4.2.2 Spring brakes should be used for parking braking.
- 4.2.3 Compressed air braking systems incorporating load sensing devices or any valve which can be adjusted to modify the system pressure shall be fitted with pressure test connections in the pressure line upstream and downstream of the device.
- 4.2.4 Air connections between all drawing vehicles and trailers must be of the two line system, using a one piece coupling, e.g. a “duomatic” coupling or when an auxiliary air supply - separate from the braking system - is required for a trailer, a “triomatic” coupling.
- 4.2.5 All power driven vehicles first registered from 1 September 1991 shall be valved and piped to the rear cross-member, unless the manufacturer forbids the attachment of a trailer with a GVM of more than 3500 kg to a particular vehicle type.
- 4.2.6 The control (service) line shall be to the left side of the coupling and coloured blue or black, the supply (emergency) line shall be to the right side of the coupling and be coloured red or yellow, or identified, within 150 mm of coupling or junction.
- 4.2.7 The coupling block shall be situated close to the centre line, preferably to the right hand side of centre.
- 4.2.8 On drawing vehicle/semi-trailer combinations the hoses shall form part of the drawing vehicle or be detachable at both ends. On other combinations the hoses shall form part of the trailer and be securely attached to the drawbar. This requirement does not apply to combinations which are not uncoupled in the course of normal operation.

Caution: When fitting the female end to the front of a semi-trailer, only the trailer version without check valves shall be used.

- 4.2.9 Each reservoir in an air brake system shall be fitted with an automatic or manual condensate drain valve at the lowest point. Where an automatic condensate valve is fitted, the reservoir shall have provision for manual operation.

### 4.3 Power driven vehicles

- 4.3.1 The systems providing service, emergency and parking braking may have common components so long as they fulfil the following conditions:
- (a) There must be only two controls (however, see section 5), in addition to any trailer hand control which may be fitted (as defined in 2.3.15) independent of each other and readily accessible to the driver from the driving seat.
  - (b) The control of the service brake system must be independent of the control of the parking brake system.
  - (c) The control for the emergency braking system may be combined with either the control for the service braking system or the control for the parking braking system, however the emergency braking action on the vehicle must be capable of graduation. If the service braking system and the emergency braking system have the same control, the parking braking system shall be so designed so that it can be actuated when the vehicle is in motion without endangering the stability of the fully laden vehicle.
  - (d) If the service braking force and circuit depend exclusively on the use, controlled by the driver, of an energy reserve, there must be at least two completely independent energy reserves each provided with its own circuit likewise independent; each of them may act on the brakes of only two or more wheels so selected as to be capable of ensuring by themselves or in associating with the emergency brake control the prescribed degree of emergency braking without endangering the stability of the vehicle during braking. It must be possible to graduate this braking action.
  - (e) The braking systems must not compound their application forces.
- 4.3.2 Gauges shall be fitted to indicate to the driver the pressure in each independent service brake energy reserve (as defined in 4.3.1(d)) and shall be visible to the driver in the normal driving position.
- 4.3.3 Where there are separate controls for the service brake system and the emergency brake system, simultaneous actuation of the two controls must not render both the service brake system and the emergency brake system inoperative, either when both brake systems are in good working order or when one of them is faulty.
- 4.3.4 Every vehicle equipped with a service brake actuated from an energy storage device (energy accumulator) must, where braking with the performance prescribed for emergency braking is impossible without the use of the stored energy, be equipped with an alarm device, in addition to any pressure gauge. The alarm device shall give an acoustical signal when the energy, in any part of the installation preceding the control valve, falls to a value which without refeeding the storage devices, guarantees that after four full-stroke actuations of the service brake control it is still possible on the fifth application to achieve the prescribed performance of the emergency brake (without failure in the service brake circuit). This alarm device must be directly and permanently connected to the circuit (See Clause 4.3.7(f)).
- This acoustical device may be rendered inoperative while the park-brake is applied and/or, at the choice of the manufacturer in the case of automatic transmission the selector is in the "Park" position.
- In verifying compliance with this clause, the vehicle's brakes shall be correctly adjusted.
- 4.3.5 The auxiliary equipment must be supplied with energy in such a way that, even in the event of damage to the source of energy, its operation cannot cause the reserves of energy feeding the brake systems to fall below the level indicated in Paragraph 4.3.4 above.
- 4.3.6 Retarders, other than exhaust brakes, shall not be capable of stalling the vehicle's engine.
- 4.3.7 Power driven vehicles capable of towing a trailer of more than 3500 kg GVM shall meet the following requirements:
- (a) The braking system shall be capable of supplying the needs of the combination at GCM to comply with Appendix A.
  - (b) The service braking system of the drawing vehicle shall incorporate automatic protection to preserve the drawing vehicle's brake circuits in the event of a failure of the trailers brake system, whereby it shall be possible to brake the drawing vehicle with the effectiveness prescribed for emergency braking.
  - (c) When the drawing vehicle's emergency braking system comes into action, there must also be a braking action in the trailer.  
If the requirements of the Specifications section of this Code are achieved by compliance with ECE 13, then when the drawing vehicle's emergency braking system comes into action, there must also be a graduated service braking action in the trailer.
  - (d) In the event of failure of the drawing vehicle's service brake system, where that device consists of at least two independent parts, the part or parts not affected by the failure must be capable of actuating the brakes of the trailer. It must be possible to graduate this braking action.
  - (e) In the event of a breakage of or a leak in one of the air connections (or of, or in such other type of connection as may be adopted), it must nevertheless be possible for the driver to actuate the brakes of the trailer by means either of the service brake control or the parking brake control, unless the breakage or leak automatically causes the trailer to be braked.
  - (f) If the requirements of the Specifications section of this Code are achieved by compliance with ECE 13 then on air braked vehicles there should be an acoustic alarm device which is activated when the pressure at the coupling head of the supply line drops below 4 kPa. This alarm device may be combined with that described in clause 4.3.4 of this Code.

**4.4 Trailers**

4.4.1 The brake systems must be such that the trailer is stopped automatically, in a progressive manner, if the supply line breaks while the trailer is in motion, or when the supply line pressure falls below 3 kPa.

4.4.2 Parking braking must be ensured when the trailer is separated from the drawing vehicle or when the supply line pressure falls below 3 kPa.

A person standing on the ground must be able to release the parking brake at least three times after the trailer has been uncoupled. In the case of air brake systems, the pressure in the supply line shall be between 650 and 6 kPa before uncoupling. These conditions must be satisfied when the brakes are adjusted to normal clearances.

The auxiliary park release device shall be such that the system is restored to normal automatically on the resumption of supply from the drawing vehicle.

4.4.3 The braking systems shall not compound their application forces.

4.4.4 As an alternative to the system capacity requirements of Appendix F, trailers with air brake systems shall have a minimum air reservoir capacity in litres equal to three times the maximum mass in tonnes carried by the trailer aides.

**5.0***Exemptions for power driven vehicles which are equipped to tow trailers*

5.1 Vehicles are exempt from clause 4.3.1(a) provided that the following requirements are met:

- (a) If there is a system park button it shall be coloured yellow
- (b) If there are control buttons which apply the parking brakes on the drawing vehicle or trailer separately, they must be guarded to prevent accidental operation during an emergency.

5.2 If the requirements of clause A3.4.1, A3.4.2, A3.5.3 and A8.1 cannot be met, the manufacturer may apply to the Statutory Authority for an exemption

*Appendix A**Distribution of braking among the axles of vehicles and requirements for compatibility between drawing vehicle and trailer***A1.0 General**

A1.1 This Appendix relates to the retardation forces acting on the vehicle which are created by friction in the brakes; retardation forces which are applied through the drive axle do not form part of this Appendix.

A1.2 The requirements of this Appendix shall be met by vehicles when laden to the gross vehicle mass, EXCEPT in the case of vehicles fitted with load sensing devices, which must meet the requirements in all states of load. See Appendix E.

A1.3 A power driven vehicle not permitted to tow a trailer with a gross vehicle mass of more than 3500 kg is exempt from the requirements of this Appendix provided that the vehicle is certified to an alternative standard that is acceptable to the statutory authority and:

- (a) The distribution of mass among the axles, when the vehicle is loaded to the gross vehicle mass (the maximum legally permitted in New Zealand), is the same (within 10%) as that to which the vehicle was originally certified; or
- (b) The vehicle is fitted with a load sensing device or an anti-lock device.

A1.4 No device shall be fitted into the cab of the vehicle which would allow the driver to alter the vehicle's braking with respect to the requirements of this

**A2.0 Symbols**

E = wheelbase

$f_i$  =  $T_i/N_i$ , adhesion utilised by axle  $i^*$

g = acceleration due to gravity

h = height of centre of gravity of the laden vehicle

h<sub>o</sub> = height of centre of gravity of drawing vehicle

h<sub>s</sub> = height of the transverse pivot axis of the coupling on which the semi-trailer rests

i = axle index (i = 1, front axle; i = 2, second axle; etc)

J = deceleration of the vehicle

M = weight of vehicle

M<sub>i</sub> = reaction normal to road surface on axle  $i$  under static conditions

MM = total normal static reaction between road surface and wheels of drawing vehicles for trailer or semi-trailer

MM = M<sub>o</sub> + M<sub>s</sub>

M<sub>o</sub> = unladen mass of vehicle

M<sub>s</sub> = M<sub>s</sub> (1 + 0.45z) used only in Paragraph 3.1, Diagram 1, Adhesion Utilisation Criterion

M<sub>s</sub> = difference between the maximum laden mass of the drawing vehicle and its unladen mass

N<sub>i</sub> = vertical reaction of road surface on axle  $i$  under braking

p<sub>m</sub> = pressure at coupling head of control line

MR = total normal static reaction normal to road surface on all wheels on laden trailer or semi-trailer

$T_i$  = force exerted by the brakes on axle  $i$  under normal braking conditions on the road

$T_M$  = sum of braking forces at the periphery of all wheels of drawing vehicles for trailers or semi-trailers

$T_R$  = sum of braking forces at periphery of all wheels of a trailer or semi trailer

$z$  = braking ratio of vehicle =  $J/g^*$

\* = Adhesion utilisation curves of a vehicle means curves showing for specified load conditions, and adhesion utilised by each axle  $i$  plotted against the braking ratio of the vehicle.

\*\* = For semi-trailers,  $z$  is the braking force divided by the static weight on the semi-trailer axle(s).

### A3.0 Requirements for power driven vehicles

#### A3.1 Two axle vehicles

- (a) The following shall hold for  $f_i$  values between 0.2 and 0.8:

$$f_i \leq \frac{z + 0.07}{0.85}$$

- (b) For two axle vehicles, the adhesion utilisation curve of the front axle shall be situated above that for the rear axle for values of  $z$  between 0.15 and 0.30. This condition is also considered satisfied if, for braking ratios between 0.15 and 0.30, the adhesion utilisation curves for each axle are situated between two parallels to the line of ideal adhesion utilisation given by the equation  $f_i z + 0.08$  as shown in Diagram 1.
- (c) In order to verify the requirements of Paragraphs A3.1 and A3.2, the manufacturer shall produce the adhesion utilisation curves for the front and rear axles calculated by the formulas:

$$f_i = \frac{T_1}{N_1} = \frac{T_1}{M_1 + \frac{zhM}{E}}; \quad f_2 = \frac{T_2}{N_2} = \frac{T_2}{M_2 - \frac{zhM}{E}}$$

- (d) Where provision is made for several possibilities of load distribution, the one whereby the front axle is the most heavily laden shall be the one considered.

A3.2 In the case of a power driven vehicle authorised to draw trailers fitted with compressed air brake systems, the pressure at full application of the braking control must be between 650 and 80 kPa at the coupling head of the supply line and between 600 and 75 kPa at the coupling of the control line, upon full service brake application, irrespective of the load condition of the vehicle. These pressures must be demonstrably present at the coupling of the drawing vehicle.

#### A3.3 Vehicles with more than two axles

- (a) The adhesion utilised by at least one of the front axles shall be greater than that utilised by at least one of the rear axles for values of  $z$  between 0.15 and 0.30. This condition is also considered satisfied if, for braking ratios between 0.15 and 0.30, the adhesion utilisation curves for each axle are situated between two parallels to the line of ideal adhesion utilisation given by the equation  $f_i = z + 0.08$  as shown in Diagram 1.
- (b) For the calculation of the adhesion utilisation the effect of suspension geometry on the axle loads during braking (brake reactivity) may be neglected.

In cases where the suspension geometry has a significant effect on the axle load distribution, the Certifier shall verify, by performing an on-road test with the vehicle loaded to GVM, that no wheels on the vehicle lock up at a deceleration of 4.5 m/s<sup>2</sup>.

#### A3.4 Vehicles other than drawing vehicles for semi-trailers

- (a) In the case of vehicles fitted with an air brake system the permissible relationship between the braking ratio  $T_R/M_R$  or  $T_M/M_M$  and the pressure ( $p_m$ ) shall be within the areas shown in Diagram 2.
- (b) Vehicles first registered before 1 July, 1991 may, at the option of the Certifier comply with Diagram 3 as an alternative to Diagram 2.

#### A3.5 Drawing vehicles for semi trailers

- (a) The dynamic load of the semi-trailer on the drawing vehicle shall be represented by a static weight  $M_s$  applied at the coupling kingpin equal to

$$M_s = M_{so}(1 + 0.45z)$$

- (b) In calculations of the effect of load transfer the following value shall be taken for  $h$ :

$$h = \frac{h_o M_o + h_s M_s}{M}$$

where  $M = M_o + M_s$

- (c) In the case of vehicles fitted with air brake systems the permissible relationship between braking rate  $T_M/M_M$  and the pressure ( $p_m$ ) shall be within the areas shown in Diagram 3.

**A4.0 Requirements for full trailers**

A4.1 The requirements set out in Paragraphs A3.1 through to A3.4 inclusive shall apply to full trailers.

**A5.0 Requirements for semi-trailers**

A5.1 For vehicles with compressed air brakes the permissible relationship between the braking ratio TR/MM and the pressure (pm) shall lie within the shaded area shown in Diagram 2.

A5.2 The requirement of Paragraph A3.1(e) shall apply to vehicles with more than one axle if the suspension geometry affects the axle load distribution during braking (brake reactive suspensions).

A5.3 If the semi-trailer is itself a drawing vehicle for a second semi-trailer (i.e. the first semi-trailer in a B-Train), then the vehicle shall meet this requirement in the loaded condition specified in A3.5.

**A6.0 Requirements for centre axle trailers**

Centre axle trailers shall be subject to the requirements of A5.

**A7.0 Load sensing devices**

A7.1 In air brake systems load sensing devices should not modulate the pressure below 70 kPa.

A7.2 Vehicles fitted with load sensing devices must be fitted with a prominent sign stating that either the rear axle set or all axle sets are equipped with load sensing devices.

A7.3 Requirements to be met in the event of a failure of the control of the load sensing device:

- (a) It shall be possible to stop the vehicle under the conditions specified for emergency braking.
- (b) Power driven vehicles authorised to tow a trailer fitted with an air brake system it must be possible to achieve a pressure at the coupling head of the control line within the range specified in Paragraph A3.2.

**A8.0 Threshold pressure tests for combination vehicles fitted with air brake systems**

A8.1 The braking at the wheels shall commence at a pressure between 55 kPa and 80 kPa, measured at the coupling head of the control line. Braking shall be deemed to have commenced when a brake torque of 100 Nm is first reached at the wheel. For trailers equipped to tow a trailer, braking at all the wheels shall commence at a pressure between 50 kPa and 85 kPa, this pressure measurement shall be made at the coupling head of the control line of the drawing trailer. If there are very good and reasonable grounds to grant an exemption to this clause, then the approval of the statutory authority must be obtained.

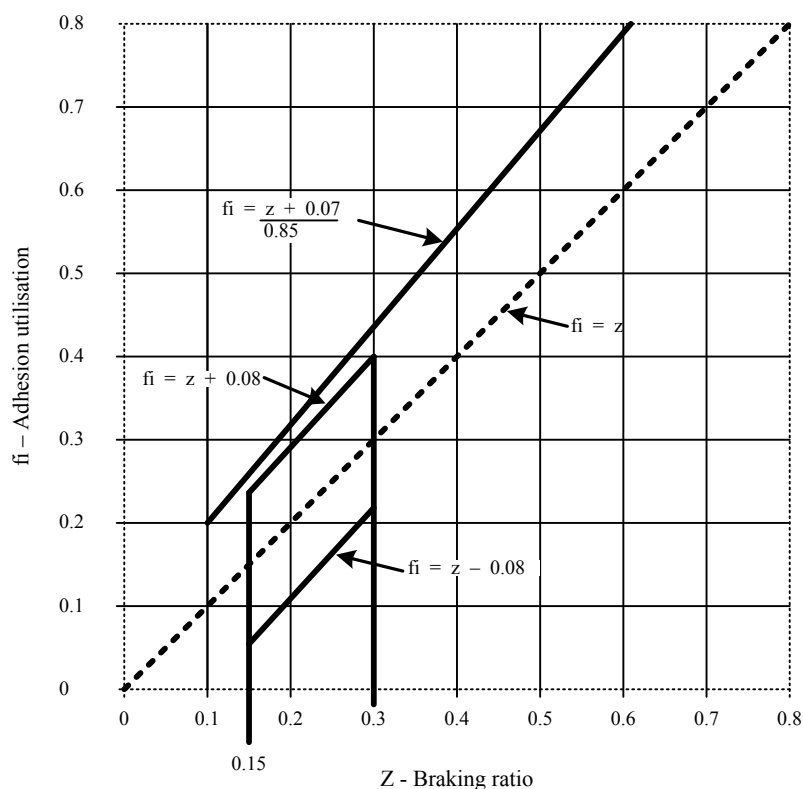
**Diagram 1****Adhesion utilisation criterion**

See Paragraph A3.1

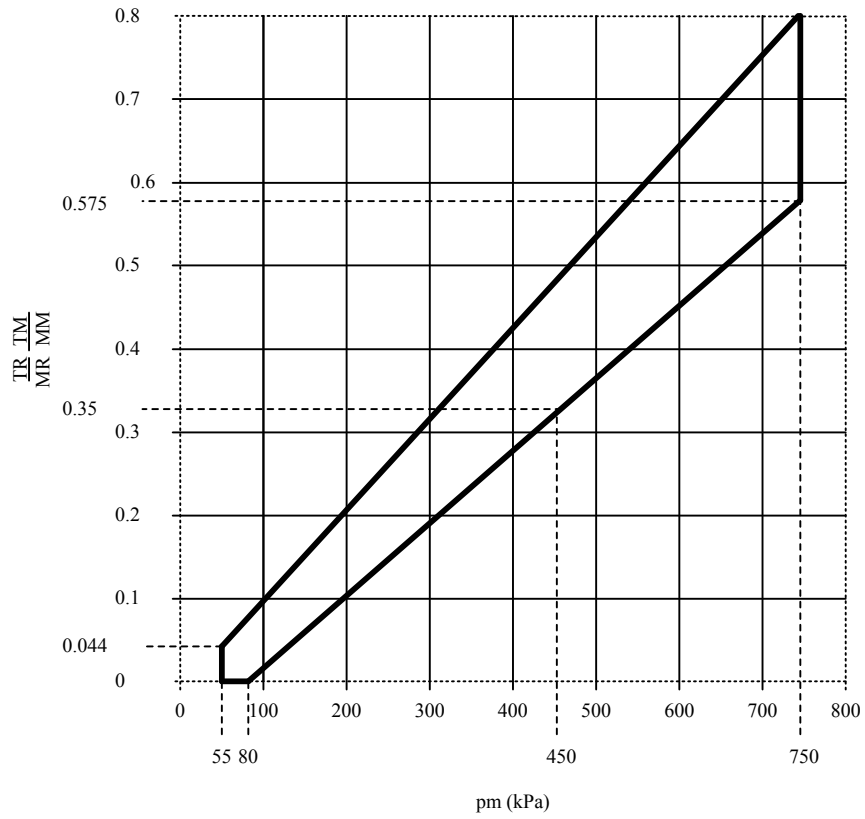

**Diagram 2**  
**Drawing vehicles, semi-trailers and full trailers**  
 (See Paragraphs A3.4, A4.1, A5.1) (See Diagram 3 for Tractors)

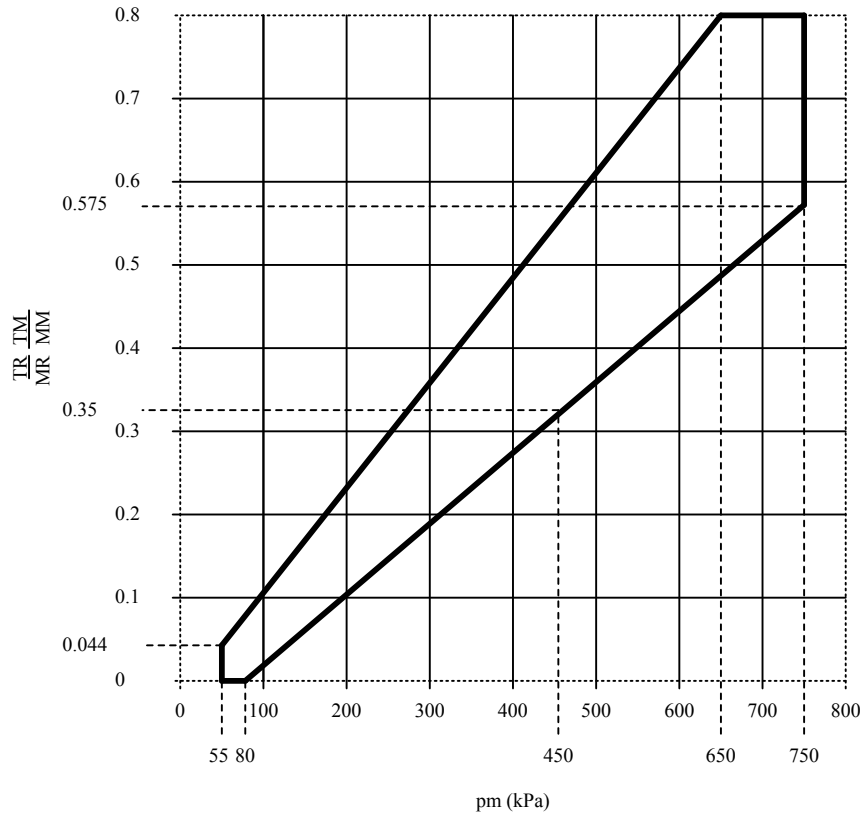

**Diagram 3**  
**Tractors for semi-trailers**

(See Paragraph A3.5. Also existing drawing vehicles and trailers first registered before 1 July 1991 which cannot be made to comply with Diagram 2)

### *Appendix B*

#### *Requirements for measuring the response time on vehicles equipped with compressed air brakes*

#### **B1.0 General**

B1.1 The response times of the brake system shall be determined on the stationary vehicle, the pressure being measured at the intake to the cylinder of the least favourably placed brake and at the coupling head if present.

During the test the free stroke in the brake cylinders of the various axles shall be as specified by the Certifier.

The response times determined in accordance with the provisions of this Appendix shall be rounded to the nearest tenth of a second. If the figure representing the hundredth is five or more, the response time shall be rounded up to the next higher tenth.

#### **B2.0 Power-driven vehicles**

B2.1 At the beginning of each test the pressure in the energy storage device shall be equal to the pressure at which the governor restores the feed to the system. In systems not equipped with a governor (e.g. limited maximum compressors) the pressure in the energy storage device at a beginning of each test shall be 90% of the pressure specified by the Certifier.

B2.2 The time elapsing from the initiation of a full brake-pedal actuation to the moment when the pressure in the brake cylinder reaches 75% of its final value shall not exceed 0.6 seconds.

The time elapsing from the release of the fully depressed brake pedal to the moment when the brake pressure reaches 25% of its initial value shall not exceed 0.6 seconds.

B2.3 In the case of vehicles having a brake coupling for trailers the response time must be measured at the coupling head. During this test a volume of  $385 \pm 5 \text{ cm}^3$  (which is deemed to be the equivalent to the volume of a pipe 2.5 m long with an internal diameter of 13mm and under a pressure of 6 kPa) shall also be connected to the coupling head of the control and supply lines. Tractive units for semi-trailers must be equipped with flexible pipes for making the connection to semi-trailers. The coupling heads will therefore be at the extremity of those flexible pipes.

The time elapsing from the initiation of a full brake pedal actuation to the moment when the pressure measured at the coupling head of the control line reaches 75% of its final value shall not exceed 0.4 seconds.

The time elapsing from the release of the fully depressed brake pedal to the moment when the coupling head pressure reaches 25% of its initial value shall not exceed 0.6 seconds.

#### **B3.0 Trailers, including semi-trailers**

B3.1 The trailers response time shall be measured without the drawing vehicle. To replace the drawing vehicle it is necessary to provide a simulator to which the trailer's control line and supply line coupling heads are connected.

B3.2 The pressure in the supply line shall be:

$$\begin{array}{r} 650 + 15 \\ - 0 \end{array} \text{ kPa}$$

B3.3 The simulator shall have the following characteristics:

(a) It must have a reservoir with a capacity of 30 litres which shall be charged to a pressure of 650 kPa before each test and which must not be recharged during each test. At the outlet of the braking control device the simulator must incorporate an orifice with a diameter of from 4.0 to 4.3 mm inclusive. The volume of the pipe measured from the orifice up to and including the coupling head shall be  $385 \pm 5 \text{ cm}^3$  (which is deemed to be equivalent to the volume of a pipe 2.5 m long with an internal diameter of 13 mm and under a pressure of 650 kPa). The control line pressures referred to in Paragraphs B3.3(c) shall be measured immediately downstream to the orifice.

(b) The braking control device must be so designed that its performance in use is not affected by the tester.

(c) The simulator must be set e.g. through the choice of an orifice in accordance with Paragraph B3.3.1 in such a way that, if a reservoir of  $385 \pm 5 \text{ cm}^3$  is joined to it, the time taken for the pressure to increase from 65 to 490 kPa (10% and 75% respectively of the nominal pressure of 6 kPa) shall be  $0.2 \pm 0.01$  seconds. If a reservoir of  $1155 \pm 15 \text{ cm}^3$  is substituted for the above mentioned reservoir the time taken for the pressure to increase from 65 to 490 kPa without further adjustment shall be  $0.38 \pm 0.02$  seconds. Between these two pressure values the pressure must increase in an approximately linear way. These reservoirs shall be connected to the coupling head without using flexible pipes. The reservoirs and pipes shall have an internal diameter of not less than 10 mm.

(d) The layouts in Diagram 1 to this Appendix give an example of the correct configuration of the simulator for setting and use.

B3.4 The time elapsing between the moment when the pressure produced in the control line by the simulator reaches 65 kPa and the moment when the pressure in the brake actuator of the trailer reaches 75% of the asymptotic value must not exceed 0.4 seconds.

When releasing pressure the time elapsing between the moment when the pressure produced in the control line by the simulator reaches 490 kPa to the moment when pressure in the brake actuator of the trailer reaches 25% of its initial value shall not exceed 0.6 seconds.

B3.5 Semi-trailers laid out for towing a second (semi) trailer shall meet the following requirements:

- The response time must be measured at the rear most coupling head. During this test a volume of  $385 + 5 \text{ cm}^3$  (which is deemed to be equivalent to the volume of a pipe 2.5 m long with an internal diameter of 13 mm and under a pressure of 650 kPa) shall also be connected to the coupling head of the supply line.
- The time elapsing between the moment when the pressure produced in the control line by the simulator reaches 65 kPa and the moment when the pressure in the rear coupling head of the trailer reaches 75% of its asymptotic value must not exceed 0.4 seconds.
- When releasing pressure, the time elapsing between the moment when the pressure produced in the control line by the simulator reaches 490 kPa to the moment when pressure in the rear coupling head of the trailer reaches 25% of its initial value shall not exceed 0.6 seconds.

#### B4.0 Partly pneumatic brake systems

B4.1 For partly pneumatic brake systems the requirements of Paragraphs B1, B2 and B3 pertaining to the coupling head shall be met. The requirements in Paragraphs B 1, B2 and B3, cornering the least favourably placed chamber shall apply to the least favourably placed pneumatic device which acts on the non-pneumatic part of the brake system.

Diagram 1 applies to Test Equipment A Supply connection with shut-off valve.

C1 = Pressure switch in the simulator, set at 65 kPa and at 490 kPa

C2 = Pressure switch to be connected to the brake actuator of the trailer, to operate at 75% of the asymptotic pressure in the brake actuator CF

CF = Brake cylinder

L = Line from orifice O up to and including its coupling head TC, having an inner volume of  $385 \pm 5 \text{ cm}^3$  under a pressure of 650 kPa

M = Pressure gauge

O = Orifice with a diameter of not less than 4 mm and not more than 4.3 mm

PP = Pressure test connection

R1 = 30 litre air reservoir with drain valve

R2 = Calibrating reservoir, including its coupling head TC, to be  $385 \pm 5 \text{ cm}^3$

R3 = Calibrating reservoir, including its coupling head TC, to be  $1155 \pm 15 \text{ cm}^3$

RA = Shut-off valve

TA = Coupling head, supply line

TC = Coupling head, control line

V = Braking control device

VRU = Relay valve

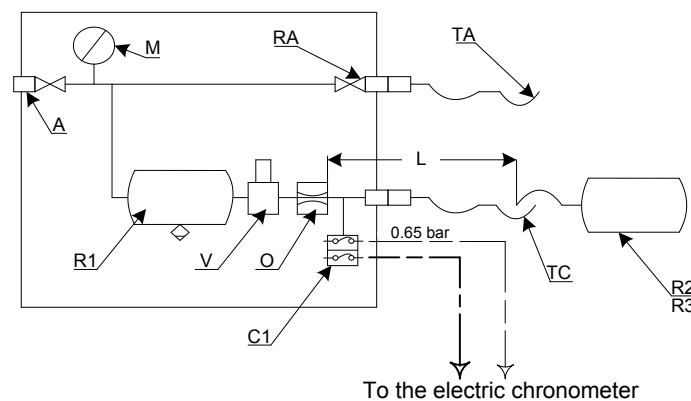

1.

*Setting the Simulator*

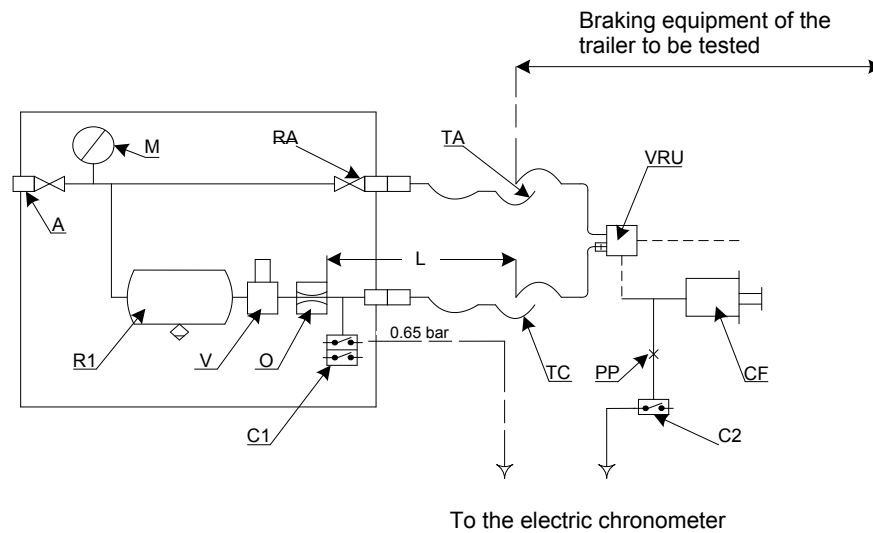

2.  
Testing the trailer

*Appendix C*  
*Statement of compliance with the New Zealand Heavy Vehicle Brake Code*

VEHICLE TYPE:	MODEL:	
MAKE:		
SERIAL NO.:		
GVM:	GCM:	
UNLADEN CoG HEIGHT:	WHEELBASE:	
UNLADEN MASS, FRONT:	UNLADEN MASS REAR:	
PAYLOAD:	POSITION: RANGE:	
PAYLOAD CoG HEIGHT:	POSITION: RANGE:	
FIFTH WHEEL HEIGHT*:		
FRONT SUSPENSION TYPE:	REAR SUSPENSION TYPE:	
REACTIVE/ NONREACTIVE:	REACTIVE/ NONREACTIVE:	
SYSTEM PRESSURE:	MAXIMUM OPERATING	PM.....KPa
	GOVERNOR CUTIN	Pg.....kPa
	TIME	Pg to Pm.....secs

Axle	Coupling Threshold kPa @ 100Nm	Brake Force kN/ kPa @ Brake Pot	Tyre Size	Friction Material		
				Make	Id No.	CoF
1						
2						
3						
4						

Axle	Brake Type	Drum Diameter	Chamber Size	Slack Length	Spring Force
1					
2					
3					
4					
5					

\* Horizontal distance from front axle set  
\* See Fifth Wheel Standard NZS 5450 (1989)

\* Park brake spring force

1.1

TRUCK OR TRACTOR			
VALVE TYPE	MAKE	MODEL	VERSION
Treadle			
Primary Circuit Relay			
Sec. Circuit Relay			
Trailer Control Relay			
Load Sensing			
Synchronising			
Quick Release			
Park Brake			
Trailer Hand Control			
TRAILER			
Relay 1			
Relay 2			
Spring Brake			
Quick Release Valve			
Pilot 1			

A copy of the calculations, test reports, and other documentation which demonstrates that this vehicle complies with the New Zealand Heavy Vehicle Brake Code must be made available to the statutory authority on request.

I, the undersigned do hereby certify that the vehicle identified above complies with all requirements of the current New Zealand Heavy Brake Code.

Date \_\_\_\_\_ Signed: \_\_\_\_\_

Certifier's Identification: \_\_\_\_\_

Name: \_\_\_\_\_ Phone: \_\_\_\_\_

Postal address: \_\_\_\_\_ Fax: \_\_\_\_\_

Position \_\_\_\_\_

Modification

I, the undersigned, do hereby re-certify the vehicle identified above, as modified complies with all requirements of the current New Zealand Heavy Brake Code.

Date: \_\_\_\_\_ Signed: \_\_\_\_\_

Certifier's Identification: \_\_\_\_\_

Name: \_\_\_\_\_ Phone: \_\_\_\_\_

Postal address: \_\_\_\_\_ Fax: \_\_\_\_\_

Position \_\_\_\_\_

*Appendix D*

*Pressure test connections for compressed air braking systems*

**Dimensions of the typical connection**

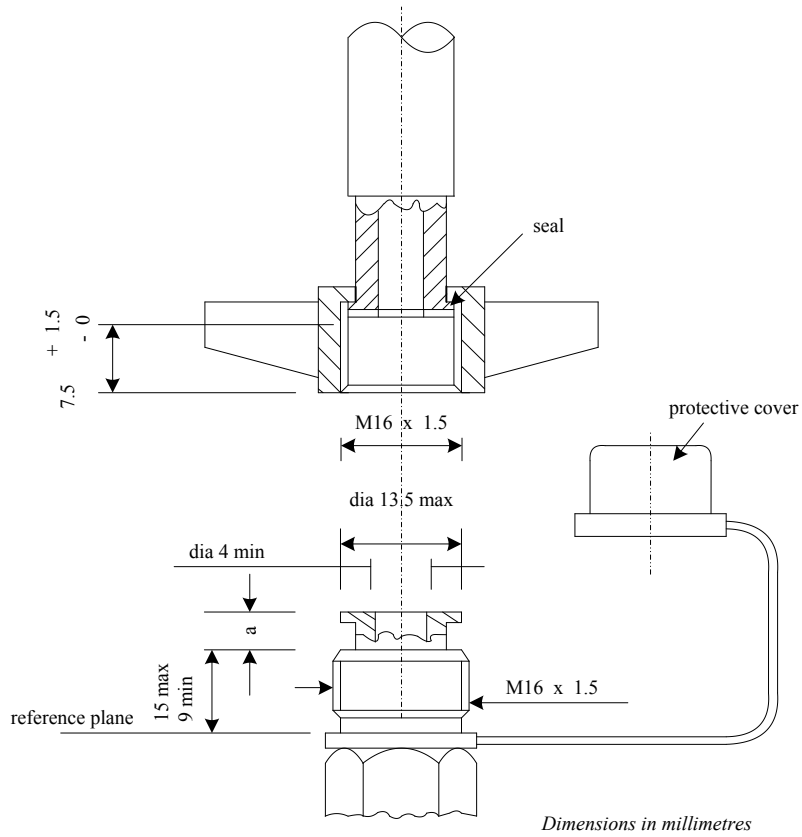

Valve position	dimension "a"
closed	5 mm
open	3 mm

Dimensions not specified are to be chosen according to the application. Seals and covers shall withstand petroleum products. Free space to be reserved around the pressure test connection

Dimensions in millimetres

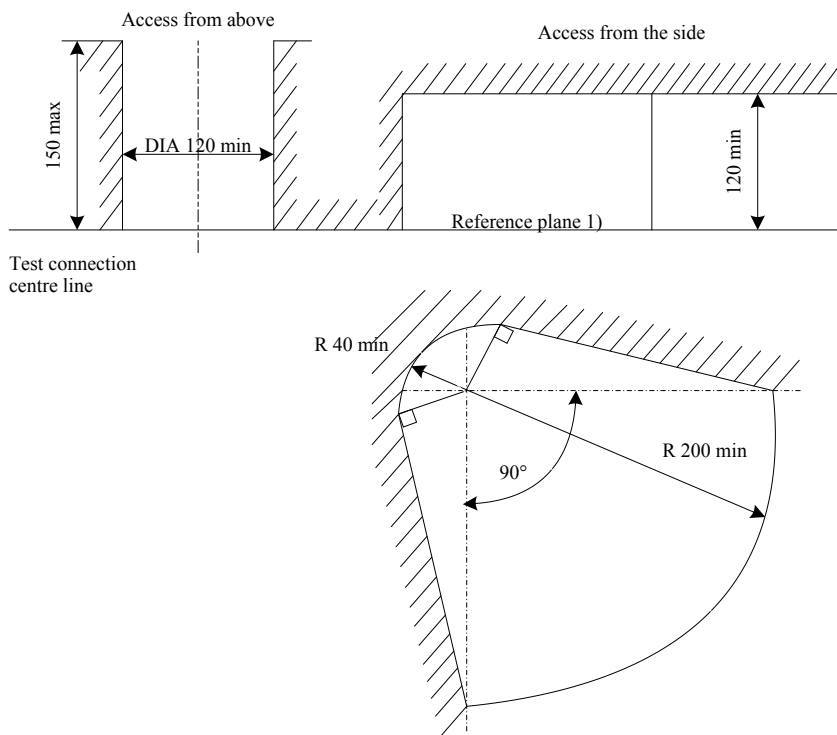

*Appendix E*  
*Maximum vehicle and axle weights. (Feb. 1989)*

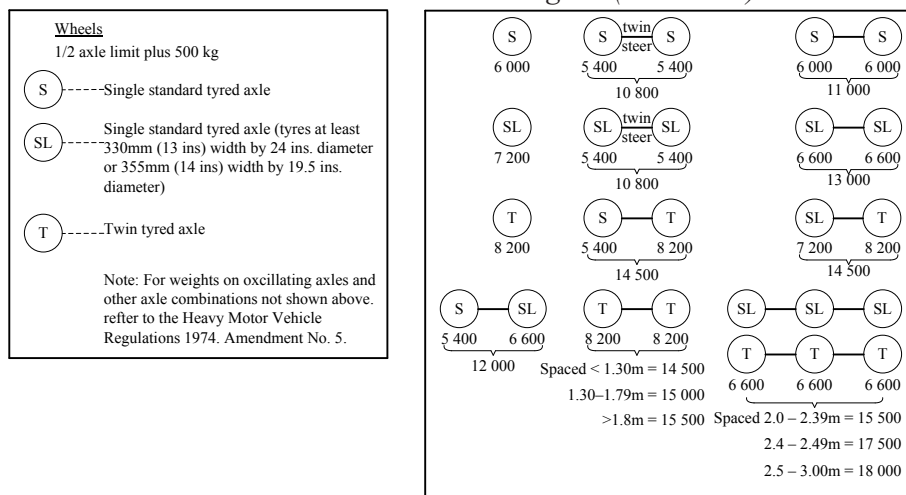

**Distance from first to last axle of any axle group of the vehicle or combination**

1.8m but less than 2.5m 15,500kg	8.2m but less than 8.8m 31,000kg
2.5m but less than 3.0m 17,500kg	8.8m but less than 9.4m 32,000kg
3.0m but less than 3.3m 19,000kg	9.4m but less than 10.0m 33,000kg
3.3m but less than 3.6m 20,000kg	10.0m but less than 10.8m 34,000kg
3.6m but less than 4.0m 21,000kg	10.8m but less than 11.6m 35,000kg
4.0m but less than 4.4m 22,000kg	11.6m but less than 12.4m 36,000kg
4.4m but less than 4.7m 23,000kg	12.4m but less than 13.2m 37,000kg
4.7m but less than 5.1m 24,000kg	13.2m but less than 13.5m 38,000kg
5.1m but less than 5.4m 25,000kg	13.5m but less than 14.4m 39,000kg
5.4m but less than 5.8m 26,000kg	14.4m but less than 14.8m 40,000kg
5.8m but less than 6.4m 27,000kg	14.8m but less than 15.2m 41,000kg
6.4m but less than 7.0m 28,000kg	15.2m but less than 15.6m 42,000kg
7.0m but less than 7.6m 29,000kg	15.6m but less than 16.0m 43,000kg
7.6m but less than 8.2m 30,000kg	16.0m and over 44,000kg

*Appendix F*

(Reprinted from ECE 13, Annex 7)

**Provisions relating to energy sources and energy storage devices (“energy accumulators”)**

**Compressed-air devices braking systems**

**1.0 Capacity of storage devices (“Energy Accumulators”)**

**1.1 General**

- 1.1.1 Vehicles on which the braking device requires the use of compressed air shall be equipped with energy storage devices (**energy accumulators**) of a capacity meeting the requirements of Paragraphs 1.2 and 1.3 below.

1.1.2 However the energy storage devices shall not be required to be of a prescribed capacity if the braking system is such that in the absence of any energy reserve it is possible to achieve a braking performance at least equal to that prescribed for the emergency braking system.

1.1.3 In verifying compliance with the requirements of Paragraphs 1.2 and 1.3 below, the brakes shall be adjusted as closely as possible.

## 1.2 Power-driven vehicles

1.2.1 The air brake reservoirs of power-driven vehicles shall be so designed that after eight full-stroke actuations of the service brake control the pressure remaining in the air brake reservoir shall be not less than the pressure required to obtain the specified secondary (emergency) braking performance.

1.2.2 Testing shall be performed in conformity with the following requirements.

- (a) The initial energy level in that energy storage device or devices shall be that specified by the manufacturer. It shall be such as to enable the prescribed performance of the service braking system to be achieved.
- (b) The energy storage device or devices shall not be fed, in addition, any auxiliary servo energy storage device or devices shall be isolated.
- (c) In the case of motor vehicles to which the coupling of a trailer or semi-trailer is authorised, the feed line shall be stopped and an energy storage device with a capacity of 0.5 litres shall be connected to the control line. The pressure in this energy storage device shall be eliminated before each braking operation. After the test referred to in Paragraph 1.2.1, the energy level supplied to the control line shall not fall below a level equivalent to one-half of the figure obtained at the first brake application.

## 1.3 Trailers and semi-trailers

1.3.1 The energy storage devices (“energy accumulators”) with which trailers and semi-trailers are equipped shall be such that after eight full-stroke actuations of the drawing vehicle's service braking device the energy level supplied to the operating members using the energy does not fall below a level equivalent to one-half of the figure obtained at the first brake application.

1.3.2 Testing shall be performed in conformity with the following requirements

- (b) The pressure in the energy storage devices at the beginning of each test shall be the maximum pressure specified by the manufacturer.
- (c) The feed line shall be stopped; in addition, any auxiliary servo energy storage device or devices shall be isolated.
- (c) The energy storage device shall not be appreciably replenished during the test.
- (d) At each brake application the pressure in the control line shall be the maximum pressure specified by the manufacturer.

## 2.0 Capacity of energy sources

2.1 **General** The compressors shall meet the requirements set forth in the following Paragraphs.

### 2.2 Definitions

2.2.1  $p_1$  is the pressure corresponding to 65% of the pressure  $p_2$  defined in Paragraph 2.2.2 below.

2.2.2  $p_2$  is the value specified by the manufacturer and referred to in Paragraph 2.2.1 above.

2.2.3  $T_1$  is the time required for the relative pressure to rise from 0 to  $p_1$ , and  $T_2$  is the time required for the relative pressure to rise from 0 to  $p_2$ .

### 2.3 Conditions of measurement

2.3.1 In all cases of r.p.m. speed of the compressor shall be that obtained when the engine is running at the speed corresponding to its maximum power or at the speed allowed by the governor.

2.3.2 During the tests to determine the time  $T_1$ , and the time  $T_2$  the auxiliary servo energy storage device or devices shall be isolated

2.3.3 If it is intended to attach a trailer to a power driven vehicle, the trailer shall be represented by an energy storage device whose maximum relative pressure  $p$  (expressed in bars) is that which can be supplied through the drawing vehicle's feed given by the formula  $p.V = 20R$  ( $R$  being the permissible maximum load, in tonnes, on the axles of the trailer or semi-trailer).

### 2.4 Interpretation of results

2.4.1 The time  $T_1$  recorded for the least favoured energy storage devices shall not exceed:

- (a) Three minutes in the case of vehicles to which the coupling of a trailer or semi-trailer is not authorised; or
- (b) Six minutes in the case of vehicles to which the coupling of a trailer or semi-trailer is authorised.

2.4.2 The time  $T_2$  recorded for the least favoured energy storage device shall not exceed:

- (a) Six minutes in the case of vehicles to which the coupling of a trailer or semi-trailer is not authorised; or
- (b) Nine minutes in the case of vehicles to which the coupling of a trailer or semi-trailer is authorised.

**2.5 Additional test**

2.5.1 If the power driven vehicle is equipped with one or more auxiliary servo energy storage devices having a total capacity exceeding 20% of the total capacity of the braking energy storage devices an additional test shall be performed during which no irregularity shall occur in the operation of the valves controlling the filling of the auxiliary servo energy storage device or devices.

2.5.2 It shall be verified during the aforesaid test that the time  $T_3$  necessary to raise the pressure from 0 to  $P_2$  in the least favoured braking energy storage device is less than:

- (a) Eight minutes in the case of vehicles to which the coupling of a trailer or semi-trailer is not authorised; or
- (b) Eleven minutes in the case of vehicles to which the coupling of a trailer or semi-trailer is authorised.

2.6 The test shall be performed in the conditions prescribed in Paragraphs 2.3.1 and 2.3.3.

**3.0 Pressure connections**

3.1 To facilitate the periodic inspection of vehicles already in use on the road, a pressure connection shall be fitted close to the least favourably placed storage device.

3.2 The pressure connection shall comply with Appendix 2 to Annex 6 to this Regulation containing the drawings according to ISO 3583- 1975.

## Schedule 4

### Heavy Vehicle Brake Code, Second edition

(reg 2.1 to reg E.3.0)

First edition published 1991

Second edition published June 1997

ISBN 0-478-20615-1

Land Transport Safety Authority, PO Box 2840

Wellington,

New Zealand

Telephone 04-494 8600, Fax 04-494 8601

#### *Acknowledgement*

The Land Transport Safety Authority (LTSA) gratefully acknowledges the substantial contributions made by the Chairman and members of the original Heavy Vehicle Brake Code Committee, individually and collectively, in the preparation of this Code and for the support given to committee members by their respective employers.

The LTSA would also like to thank the various organisations that have made vehicles, equipment and services available, for without their support the production of this Code would not have been possible.

The LTSA is grateful to the present members of the Heavy Vehicle Brake Code Technical Advisory Group for their continuing support and guidance for the on-going implementation of the Code.

#### *Contents*

Preface to the first edition

Preface to the second edition

Aims of the Code

1.0 Scope and interpretation

2.0 Definitions

3.0 Compliance

4.0 Specifications

5.0 Exemptions for power-driven vehicles which are equipped to tow trailers

Appendices

A. Distribution of braking among the axles of vehicles and requirements for compatibility between towing vehicle and trailer.

B. The standard procedure for measuring the response time on vehicles equipped with compressed air brakes (based on ECE 13, Annex 6).

C. Statement of compliance with the New Zealand Heavy Vehicle Braking Code.

D. Pressure test connections for air-braking systems

E. Provisions for air compressors and their receivers (based on ECE13, Annex 7)

#### *Preface to the first edition*

Background to the New Zealand situation

In New Zealand, power-driven vehicles are imported from overseas suppliers, the majority coming from Europe, North America, Japan and Australia. The result is that the local powered-vehicle population has variations of the braking systems common to the country of origin. Locally manufactured trailers generally use imported brake components and are only required to meet emergency stop and parking performances.

By legislation, New Zealand has lower individual axle loadings than are common in the countries from which the power-driven vehicles and trailer components are sourced. The road tax on heavy vehicles is collected through a system known as

Road User Charges and applies to vehicles over 3500 kg gross weight. It is allocated according to gross vehicle mass, axle configuration and distance travelled. This form of road tax has given rise to a situation where operators are encouraged to fit additional axles to reduce possible road damage. Braking problems therefore can arise because the axles used on these vehicles are designed for substantially higher loadings and are fitted with brakes sized accordingly.

#### The Code

This Code has been developed to improve the braking performance of heavy vehicles in New Zealand by an industry-based committee consisting of representatives from the MVMA, NZRTA, IRTENZ, IRL, NZTTMF and LTSA. The Code is based on European brake performance requirements, namely the United Nation Economic Commission of Europe Regulation 13, (ECE 13). To facilitate its adoption into the Brake Code, some simplifications to the regulation have been made and special New Zealand requirements have been included. Every effort has been made to minimise the extent of modifications necessary for existing vehicles to meet the Code requirements.

This Code has been gazetted as the recommended alternative braking standard (under Regulation 16A(2) of the Heavy Motor Vehicle Regulations 1974) to the current Interim Performance Heavy Vehicle Braking Specification, for vehicle combinations operating with a gross combined mass (GCM) of between 39,000 kg and 44,000 kg.

#### Preface to the second edition

The present Heavy Vehicle Brake Code Technical Advisory Group (TAG) was established in 1993 to replace the original Heavy Brake Code Committee. The Technical Advisory Group is made up of representatives from the transport industry and advises the Land Transport Safety Authority on the continuing implementation of the Code.

It is intended that in due course:

- the Code will be the principal guide to compliance with the statutory braking requirements for heavy vehicles;
- the range of vehicles the Code currently applies to may be extended. The present lower limit of 39,000 kg GCM may be reduced further to cover all significant heavy vehicles operating in combination.

Any extension to the range of heavy vehicles covered by this Code would only be made after consultation with the TAG and transport industry.

Vehicle combinations operating in excess of 44,000 kg and with a valid overweight permit are exempted from having to comply with this Code by notice in the New Zealand Gazette.

#### Aims of the Code

The aim of this Code is to improve heavy vehicle safety by standardising braking performance by:

- ensuring certified individual vehicles in a fully laden state meet the required braking performance at all levels of braking and axle loads permitted under the Heavy Motor Vehicle Regulations 1974;
- ensuring the continuing compliance of vehicles certified to this Code;
- improving the compatibility between powered vehicles and trailers to ensure that vehicles in a combination function in harmony, provide optimum brake performance and improve directional stability; and
- introducing a brake control system with common characteristics on all heavy motor vehicles operating between 39,000 kg and 44,000 kg GCM. This ensures protection of individual vehicles, efficient emergency braking and safe parking of individual vehicles and vehicle combination.

#### Auxiliary brake equipment

The requirements for supplementary brake equipment (which are permitted by the Code) are specified. This equipment includes such items as trailer hand control, anti-lock braking systems (ABS), load sensing devices and engine retarders. If any of this equipment is fitted to a certified vehicle then the vehicle must be re-certified.

### 1.0

#### *Scope and interpretation*

This Code is the preferred alternative braking standard to the Interim Performance Specification for Heavy Vehicle Braking, published by the previous Ministry of Transport. All vehicles operating in combination, with a GCM between 39,000 kg and 44,000 kg, must comply with either braking standard. Any changes to the application of the Code will be published in the New Zealand Gazette.

This Code applies to power-driven and towed vehicles equally with each vehicle assessed individually.

In this Code the words *must* or *shall* indicate a mandatory requirement to be met in order to comply with the Code. The word *should* indicates a recommendation.

### 2.0

#### *Definitions*

#### **2.1 General**

2.1.1 **After market:** the general market place in which vehicle parts, in particular friction material, are supplied by producers and importers other than the original vehicle manufacturers (OE).

- 2.1.2 **Brake Code mass (BCM):** the maximum laden mass of a vehicle as calculated using statutory maximum axle load criteria. (This measure of vehicle mass must be used in all Code calculations (refer Appendix “A”), but not entered on the vehicle's Certificate of Compliance.)
- 2.1.3 **certifier:** a person who is a manufacturer or their agent and any other person who is recognised by the [Agency] as being experienced in the braking of heavy motor vehicles for the purposes of the Code. Certified has a corresponding meaning.
- 2.1.4 **Code:** the New Zealand Heavy Vehicle Brake Code, Second edition
- 2.1.5 **Drawing vehicle:** a vehicle equipped to tow a trailer and includes a truck, a tractor unit or trailer, e.g. the centre trailer of a B-train.
- 2.1.6 **examiner:** a person who has passed a suitable training course recognised by the New Zealand Qualifications Authority and is recognised by the [Agency] as being experienced in the braking of heavy motor vehicles and who can act on a Certifier's behalf to certify that a vehicle meets the Code.
- 2.1.7 **gross vehicle mass (GVM):** the gross laden mass of a vehicle as specified by the manufacturer or the [Agency], whichever is the greater.
- 2.1.8 **gross combination mass (GCM):** is equal to the sum of the manufacturer's recommended GVMs of the towing and towed vehicles operating in a combination. It is the greater of that specified by the manufacturer of the drawing vehicle(s) or the [Agency].
- 2.1.9 **manufacturer:** for the purposes of this Code, means a person acceptable to the [Agency], who engages in the manufacture, assembly, or importation of vehicles with a GVM of more than 3500 kg.
- 2.1.10 **Mass and weight:** have the same meaning in the Code.
- 2.1.11 **Operator:** means a person who drives or causes or permits a vehicle to be on any road.
- 2.1.12 *Revoked.*

### The Director

- 2.1.13 **The Statutory Authority:** means the Crown agency responsible for enforcing transport legislation.
- 2.1.14 **Tractor:** means a vehicle designed to tow articulated trailers.
- 2.1.15 **Vehicle type:** a category of vehicle which does not differ in such essential respects as:
  - vehicle category (e.g. passenger vehicle or goods vehicle, power-driven vehicle or trailer);
  - gross vehicle mass (as defined above);
  - distribution of mass among the axles;
  - type of brake system;
  - number, relative position and arrangement of the axles and suspension types.
- 2.1.16 **Unladen mass:** means the mass of the vehicle complete with fuel and equipment necessary for it to undertake its designed purpose.
- 2.1.17 **A wheel:** in the Code means a disc assembly on which a vehicle runs and includes the wheel disc, rim and tyre. A twin wheel is taken to mean two wheels.
- 2.1.18 **Modify:** means to change a vehicle from its original state by altering or substituting any part or component; but does not include repair. Modified and modification have corresponding meanings.

## 2.2 Trailer Definitions

- 2.2.1 **Centre axle trailer:** also known as a **simple trailer** means a trailer (not being a full trailer or semi-trailer) fitted with a drawbar rigidly attached to the chassis or body of the trailer.
- 2.2.2 **Full trailer:** a trailer fitted with at least two axle sets equipped with a drawbar which controls the direction of the front axle set and which does not transmit any significant vertical load to the towing vehicle.
- 2.2.3 **Semi-trailer:** also known as an **articulated trailer** means a trailer having one axle set positioned behind the centre of gravity of the vehicle (when fully laden) so that a substantial portion of the towed vehicle's laden mass (GVM) is carried by the towing vehicle.
- 2.2.4 **Simple trailer:** also known as a **centre axle trailer** means a trailer (not being a full trailer or semi-trailer) fitted with a drawbar rigidly attached to the chassis or body of the trailer.
- 2.2.5 **Trailer:** a vehicle without motive power that is constructed for the purpose of being towed or propelled by a motor vehicle from which it is readily detachable.

## 2.3 Brake Definitions

- 2.3.1 **Auxiliary line:** also known as **auxiliary**, means an air supply line run from the towing vehicle to the trailer(s) to operate equipment other than brakes.
- 2.3.2 **Auxiliary braking equipment:** brake equipment supplementary to the fundamental brake system which gives the driver greater control and improved brake performance, such equipment includes:
  - anti-lock braking system (ABS) - a central brake control system which limits the locking up of wheels during a brake application;
  - load sensing device - a device which controls the brake air pressure to a particular axle, depending on the load carried by that axle;

- trailer hand control - a manual control that can be used by the driver to apply a graduated braking action to the trailer alone;
  - retarder - fitted to either the vehicle's engine or transmission to augment its braking capability during a prolonged brake application, e.g. a long descent.
- 2.3.3 **Air brake system:** a system in which braking requires the use of compressed air.
- 2.3.4 **An axle set:** in terms of brake relining refers to when the brake lining is replaced at one end of an axle, the brake lining at the other end of the same axle must also be replaced using the same material.
- 2.3.5 **Brake:** means the assembly in which frictional forces opposing the movement of the vehicle are developed.
- 2.3.6 **A brake application** occurs when the service brakes of a vehicle have been applied and released.
- 2.3.7 **Brake coupling:** also known as a **coupling head** or **coupling block**, the device for connecting the control and supply lines of the drawing vehicle to the control and supply lines of the trailer.
- 2.3.8 **Braking force:** the retarding force generated by a brake assembly.
- 2.3.9 **Brake system:** means the combination of parts whose function is to progressively reduce the speed of a moving vehicle or bring it to a halt, or keep it stationary if it is already halted. The system includes the control, the circuit and the foundation brake.
- 2.3.10 **Circuit:** the combination of components between the control and the foundation brake that links them functionally. The circuit may be mechanical, hydraulic, pneumatic, electrical or mixed. Where the braking power is derived from or assisted by a source of energy independent of the driver but controlled by the driver, the reservoir of energy in the device is likewise part of the circuit.
- 2.3.11 **Control:** part of a brake system which is actuated directly by the driver to regulate the energy required for braking a vehicle. This energy may be the muscular energy of the driver, or energy from another source controlled by the driver.
- 2.3.12 **Control (Service) line:** the part of the circuit which transmits the service brake signal.
- 2.3.13 **Coupling head:** also known as a **brake coupling** means the device for connecting the control and supply lines of the drawing vehicle to the control and supply lines of the trailer.
- 2.3.14 **Effective tyre radius:** is the rolling radius of the tyre under the maximum permitted load. For the purposes of the Code, it is equal to the height of the axle centre line above the road's surface. Where the rolling radius is within 5% of the nominal tyre radius, the nominal tyre radius must be used.
- 2.3.15 **Emergency brake:** a system that makes it possible to undertake a controlled stop of a vehicle or combination in the event of a failure of the service brake.
- 2.3.16 **Foundation brake:** the basic brake assembly fitted to each axle or road wheel which produces the braking force necessary to bring a vehicle to a stop. Includes the complete drum or disc brake.
- 2.3.17 **Gradated braking:** braking which can be easily and progressively varied in a controlled manner. The resultant brake force must vary in direct proportion to the action of the control.
- 2.3.18 **Load sensing device:** a device fitted to an axle to regulate the braking effort of that axle in proportion to the load carried by it. (See Appendix A.7.)
- 2.3.19 **Park brake or parking brake:** a brake readily applied and capable of remaining applied for an indefinite period without further adjustment after the initial application.
- 2.3.20 **Pressure:** refers to the pressure of compressed air in a brake system, using a pressure gauge.
- 2.3.21 **Retarder:** a device permanently fitted to a powered vehicle to provide a continuous braking effort not generated by a brake. (See 2.3.2).
- 2.3.22 **Service brake:** a brake normally used intermittently to slow down and stop a vehicle.
- 2.3.23 **Supply (Emergency) line:** the part of the circuit through which air required to actuate the brakes is supplied.
- 2.3.24 **Spring brake:** a brake in which the energy required for braking is supplied by one or more springs acting as an energy storage device.
- 2.3.25 **Threshold pressure:** the lowest air pressure at which braking is deemed to have commenced, as measured in the control line at the coupling head. (See Appendix A.8)
- 2.3.26 **Trailer hand control:** means a hand operated control capable of applying a graduated braking action on the towed vehicle (s) only.

### 3.0

#### *Compliance*

##### **3.1 Initial compliance of a vehicle with this Code is the responsibility of the Certifier.**

- 3.1.1 The Certifier must provide the [Agency] with one copy of the Statement of Compliance for each vehicle as requested, in the format prescribed in Appendix C or as generated by the latest authorised Brake Code computer programme.
- 3.1.2 The Certifier must supply one copy of the Statement of Compliance (in the format prescribed in Appendix C or as generated by the latest authorised Brake Code computer programme) to the vehicle's operator. The operator of the vehicle is responsible for ensuring that the Statement of Compliance remains with the vehicle's documentation, but not necessarily on the vehicle.

3.1.3 The Certifier is responsible for the safe keeping of all the calculations, test reports and other documentation for each vehicle issued with a Statement of Compliance and also for making copies of such material available to the [Agency] on request. This material must include:

- a) A set of calculations which must demonstrate compliance as follows:
  - service brake performance (refer to Appendix A);
  - emergency brake performance (refer to 4.1.2);
  - parking brake performance, only on vehicles with spring brakes fitted to more than half of the wheels in contact with the road surface;
  - where auxiliary braking equipment has been fitted, details of its performance and possible effects on the primary, secondary and parking brake systems of the vehicle.
- b) A demonstration of compliance with the following requirements:
  - service brake performance (refer to 4.1.1);
  - parking brake performance (refer to 4.1.3) unless determined by calculation as above;
  - compressors and air reservoirs (refer to 2.0 Appendix E);
  - current New Zealand pressure vessel requirements;
  - brake torque reaction test (refer to A.3.3.b);
  - load sensing valve operation (refer to A.7).
- c) A schematic Diagram of the brake circuit including a list of the components in the braking system.
- d) A label of permanent material must be fixed to the vehicle, as close as practicable to the vehicle's manufacturers' identification plate. The label must include the words "...NZHVBC Edition No. ...."
 

Certifiers should include the details of following items of the brake system on this label:

  - size of brake chambers;
  - effective length of slack adjusters;
  - the size of tyres at time of certification to the Code; and
  - grade of lining material used.
- e) Where significant changes have been made to the brake system, it is the responsibility of the operator to ensure the vehicle's brake system:
  - remains in compliance with the Code (refer 3.2.2); and
  - that a new data label is issued by the Certifier reflecting any system changes.

3.1.4 When a Certifier ceases to be involved with the design certification to this Code, the above mentioned records must be forwarded to another practising Certifier and the [Agency] notified of this change.

### 3.2 Continued Compliance

Continued compliance of a vehicle with the Code is the responsibility of the vehicle operator.

#### 3.2.1 Maintaining the brake system:

- a) The maintenance of a certified vehicle's brakes and brake system must follow good trade practice so that the vehicle's continued compliance with the Code is not compromised. Full and detailed records must be kept of the work undertaken and of the parts supplied and installed. A copy of this information must be made available to the vehicle operator.
- b) Only components which do not alter the performance and quality as originally specified by the Certifier can be used when maintaining a certified brake system. Replacement brake linings must be supplied with a compliance certificate in accordance with the details on the Statement of Compliance and fitted in axle sets (refer 4.1.5 and Appendix C).

#### 3.2.2 Modifications to the vehicle or the brake system:

- a) For every significant modification of the vehicle or of its braking system, the brake systems must be re-certified to ensure continued compliance with this Code. A new Statement of Compliance must be issued.
- b) The Certifier must provide the [Agency] with the full details of the modification and complete the modification portion of the Statement of Compliance with the amended information (in the format prescribed in Appendix C or current Brake Code computer programme). The vehicle operator must ensure a copy of this modification certificate remains with the vehicle records.
- c) Where the modification is appropriate to all vehicles of a particular vehicle type, the Certifier may issue a certificate to this effect which clearly defines the modification and the vehicles for which it is appropriate.

## 4.0

### *Specifications*

#### 4.1 Requirements of the brake system

Before a vehicle can be set up to comply with the Brake Code, it must meet the current serviceability requirements laid down by the statutory authority and the Specifications of the braking equipment manufacturer.

The brake system, as defined in 2.3.9, must also comply with the following provisions.

4.1.1 Service brakes must be capable of:

- stopping the fully laden vehicle within 7 metres from 30 km/h (equivalent to an average deceleration of 5 m/s<sup>2</sup>); and
- controlling the movement and retardation of the vehicle or vehicles in combination by means of a graduated braking action. The driver must be able to achieve this graduated braking action from the driving seat without removing their hands from the steering control.

*Note: Where the vehicle was first registered in New Zealand on or after 1 November 1990, the service brake must operate on all wheels in contact with the road (wheel definition refer to 2.1.17).*

4.1.2 The emergency brakes must be:

- capable of stopping the fully laden vehicle or vehicle combination within 18 metres from 30 km/h, (equivalent to an average deceleration of 2 m/s) in the event of failure of the service brake system; and
- operable from the driving seat while keeping at least one hand on the steering control.

*Note: Where the vehicle was first registered in New Zealand on or after 1 November 1990 the emergency brake must operate on at least half of the road wheel (wheel definition refer to 2.1.17).*

For the purposes of this provision, it is assumed that not more than one failure of the service brake system will occur at any one time.

4.1.3 The park brake(s) must be able to:

- hold the fully laden vehicle on both a rising and falling gradient of 1 in 5 on a surface sealed to highway standard; or
- bring the fully laden vehicle to a stop in 18 m from 30 km/h; and
- remain in the applied position by a purely mechanical device which, after the initial application, remains applied indefinitely; or
- be operated from the normal driving position, and cause the vehicle, and any vehicle that it is designed to tow, to be brought to a standstill, subject in the case of a trailer to the provisions of 4.4.1.

*Note: Where the vehicle was registered in New Zealand on or after 1 November 1990 the emergency brake must operate on at least half of the wheels in contact with the road (wheel definition refer to 2.1.17).*

4.1.4 Brakes must be capable of ready manual or automatic adjustment to accommodate wear. The components of the control circuit and foundation brakes must possess a reserve of travel so that, when the brakes become heated or the brake linings have reached a certain degree of wear, effective braking is maintained without the need for immediate adjustment.

4.1.5 All components and devices in the brake system (including hoses and air connections) must comply with at least one appropriate and recognised international, national or association standard where such standards exist. Recognised standards include:

- Australian Design Rule (ADR)
- Standards Association of Australia Standard (AS)
- Society of Automotive Engineers Standard (SAE)
- British Standard (BS)
- Japanese Industrial Standard (JIS)
- Economic Commission of Europe Regulation (ECE)
- European Economic Community Directive (EEC)
- International Standard Organisation Standard (ISO)
- German Industrial Standard (DIN)

In addition to other standards recognised by the [Agency].

*Note: In all cases the supplier and importer is responsible for providing proof of compliance.*

a) For newly registered vehicles:

- the friction materials are fitted as original equipment (OE) by the manufacturer and meet an appropriate and recognised standard;
- a design coefficient of friction is supplied by the vehicle manufacturer.

b) Supplying the after market, the friction material must:

- be approved by either the vehicle's original manufacturer or by the supplier for a specific application;
- comply with an internationally recognised and appropriate standard;
- be supplied with a design coefficient of friction.

*Note: Claims of compliance and nominated coefficients of friction must be supported by:*

- documented proof from the manufacturer of the friction material;
- evidence of the friction material being used in similar vehicles and conditions.

(c) Recognised friction material standards are included in the following:

- *JIS D4411: Brake Linings for Automobiles*
- *ECE R 13.05 Uniform Provisions Concerning the Approval of Vehicles with Regard to Braking*
- *71/320/EEC: Braking Systems*
- *FMVSS 121: Air Brake Systems. Truck, Buses and Trailers (modified to New Zealand conditions).*

Note: The Federal Motor Vehicle Safety Standard (FMVSS) No 121 test results must be modified to take into account the lighter axle loads used in New Zealand. The modification applies to the test results obtained under this standard's dynamometer test procedure, where:

Friction material manufacturers' = M NZ wheel load = 4000 kg test wheel load.

Friction material manufacturers' = AL NZ AL Factor\* = 120 test AL Factor\*.

$$\frac{M}{4000} \times \frac{120}{AL^*}$$

From the plotted results of the dynamometer test, the Brake Retardation Graph, determine the brake retardation “Y” for the given chamber air pressure of 80 psi, using the relationship:

$$\text{Modified brake retardation } R = X \times Y > 0.41$$

- 4.1.6 Vehicles which have had anti-lock braking systems (ABS) fitted must comply with all the requirements of this Code.
- 4.1.7 Traction control systems may utilise the brake system components provided the system is fail-safe and does not interfere with normal braking processes.
- 4.1.8 A trailer hand control valve must not modify the effect of the normal service braking action on the trailer, and must be self cancelling (i.e. must automatically return to the off position when released.)
- [\* the AL Factor is equal to the product of the length (inches) of the slack adjuster, multiplied by the chamber area (inches squared) and expressed in inches cubed.]

## 4.2 Air Brake System

- 4.2.1 A pressure test connection complying with the dimensional requirements of Appendix D must be fitted to the air inlet of the least favourably placed brake chamber (or pneumatic device in the case of partly pneumatic brake systems) on each independent circuit of the braking system. (See also Appendix B.)
- 4.2.2 Spring brakes are the preferred type of park brake for Coded vehicles.
- 4.2.3 Compressed air braking systems incorporating load sensing devices or any valve which can be adjusted to modify the system pressure, must be fitted with pressure test connections in the pressure line upstream and downstream of the device. The pressure test connections must be in accordance with Appendix D.
- 4.2.4 Air connections between all towing vehicles and trailers must be of the two line system using a one piece coupling, e.g. a Duomatic coupling, or when an auxiliary air supply (separate from the braking system) is required for a trailer, a Triomatic coupling.
- 4.2.5 All power-driven vehicles must be valved and piped by the manufacturer or authorised agent, to an appropriate coupling location, unless the manufacturer forbids the attachment of a trailer with a GVM of more than 3500 kg to a particular vehicle type.
- 4.2.6 The control (service) and supply (emergency) air lines on a Coded vehicle must be installed so that when facing the cover of the female section of the coupling housing:
- the control (service) line must be on the left side of the housing and coloured blue or black and the supply (emergency) line must be on the right side of the housing and be coloured red or yellow; and
  - the required colour coding must be situated within 150 mm of the coupling or junction.

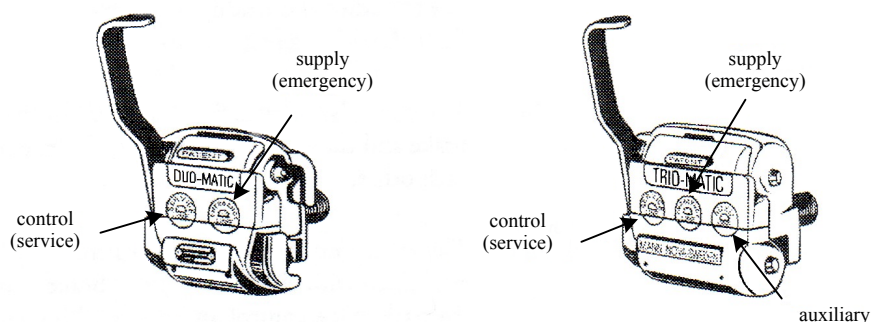

### Typical duomatic coupling / Typical triomatic coupling

- 4.2.7 The coupling block must be situated close to the centre line, preferably to the right hand side (i.e. driver's side) of centre.
- 4.2.8 For vehicles towing semi-trailers, the hoses connecting the towing and towed vehicles are to be considered as part of the towing vehicle or be detachable at both ends. On other vehicle types, the hoses are to be treated as part of the trailer and must be securely attached to the drawbar.

**Caution: The female coupling mounted on the front of a semi-trailer MUST NEVER be fitted with check valves.**

- 4.2.9 Each air reservoir in an air brake system must be fitted with a condensate drain valve at the lowest point. Where an automatic condensate valve is fitted, it must have a provision for manual operation.

### 4.3 Power-driven vehicles

- 4.3.1 The systems providing service, emergency and parking brake vehicles first registered on or after 1 November 1990 may have common components so long as they fulfil the following conditions:

- There must be only two controls (however, see Section 5), in addition to any trailer hand control (refer to 2.3.26) which may be fitted, independent of each other and readily accessible to the driver from the driving seat.
- The controls and associated systems of the service brake and the park brake must be independent of each other.
- The emergency brake system control may be combined with either the service brake control or the park brake control and the resulting emergency braking action must be gradatable. If the service and the emergency braking systems have the same control, the park brake must be so designed that it can be applied when the vehicle is in motion without endangering the directional stability of the fully laden vehicle.
- Where a vehicle's service brakes depend exclusively on compressed air, there must be at least two completely independent brake actuating circuits, each with its own air reservoir. Each circuit must supply the foundation brakes at both ends of one or more axles so that when applied either by itself or in conjunction with the emergency brakes, the required level of braking can be achieved without compromising the directional stability of the fully laden vehicle. Refer to 4.4.3 regarding compounding of braking efforts.

- 4.3.2 Gauges must be fitted to indicate to the driver the pressure in each independent service brake air reservoir (as defined in 4.3.1.(d)) and must be visible to the driver in the normal driving position.

- 4.3.3 Where there are separate controls for the service brake system and the emergency brake system, simultaneous actuation of the two controls must not render both the service brake system and the emergency brake system inoperative, either when both brake systems are in good working order or when one of them is faulty.

- 4.3.4 Every vehicle equipped with compressed air operated service brakes and where the prescribed emergency braking performance cannot be achieved without the use of the compressed air, the air reservoirs must be equipped with a low pressure alarm device in addition to any pressure gauges. This alarm must sound loudly when the brake reservoir pressures fall below the minimum safe operating pressure recommended by the manufacturer. The reservoir of compressed air with the compressor stopped must be sufficient to provide:

- a minimum of five full brake applications with full release;
- achieve the prescribed emergency braking before the low pressure alarm sounds; and
- two full brake applications thereafter.

The alarm devices must be directly and permanently connected to the circuit. (See 4.3.7.0.f).

The low pressure alarm may be rendered inoperative while:

- the park-brake is applied; and
- the selector is in the Park position in vehicles fitted with an automatic transmission.

In verifying compliance with this clause, the vehicle's brakes must be correctly adjusted.

- 4.3.5 Where auxiliary equipment uses compressed air, the braking circuits shall be protected to ensure they will have first call upon the air supply from the compressor, should the system air pressure fall below the level indicated in 4.3.4

- 4.3.6 All retarders, in particular the exhaust and engine compression type of brake, must not be able to stall the vehicle's engine under any circumstances. The retarder's control system must be capable of disengaging the retarder at the engine speed recommended by the vehicle manufacturer, when slowing down from its normal operating speed range.
- 4.3.7 The braking systems of power-driven vehicles capable of towing a trailer of more than 3500 kg GVM must meet the following requirements:
- Be capable of supplying the necessary air supply and brake control for the combination at the vehicle's GCM so as to comply with Appendices A and E.
  - The service brake system of the towing vehicle must include automatic protection (tractor protection) to preserve the integrity of the towing vehicle's brake circuits should the trailer's brake system fail, so that the towing vehicle meets the mandatory braking requirements for emergency braking.
  - When the towing vehicle's emergency braking system comes into action, there must be a braking action on the trailer. If the requirements of the Specification section of this Code (section 4) are achieved by compliance with ECE 13, then when the towing vehicle's emergency braking system operates, there must be a graduated application of the service brake on the trailer.
  - Where the towing vehicle's service brake system consists of at least two independent sub systems and a fault occurs in one them, those sub-systems not affected by the fault must be capable of actuating the brakes on the trailer. It must be possible to graduate this braking action.
  - In the event of a breakage of or a leak between the connecting "supply line" between the towing vehicle and trailer, the driver must be able to actuate the brakes of the trailer from his normal driving position using either the service or park brake control.
  - If the requirements of this Specifications section of the Code are achieved by compliance with ECE 13, then on air braked vehicles there should be an acoustic alarm device which is activated when the pressure at the coupling head of the supply line drops below 450 kPa. This alarm device may be combined with that described in 4.3.4 of this Code.

#### 4.4 Trailers and semi-trailers

- 4.4.1 The trailer park brake system must be capable of:
- Stopping a fully laden full trailer automatically in a progressive manner, when the supply line either:
    - breaks while the trailer is in motion (statutory break-away function), or
    - line pressure falls below 310 kPa.
  - Holding all other types of heavy trailer indefinitely, in a fully laden condition, on a 1 in 5 slope or when the "supply line" air pressure falls below 310 kPa.
  - Being fully released at least three times by means of the auxiliary park brake release control after the trailer has been uncoupled. In the case of air brake systems, the pressure in the supply line must be between 650 and 665 kPa before uncoupling.
- 4.4.2 The auxiliary park brake release device must be able to be restored automatically to its normal operating state on resumption of the air supply from a towing vehicle.
- 4.4.3 The brake systems must not compound their individual brake forces.
- 4.4.4 As an alternative to the system capacity requirements of Appendix E, trailers with air brake systems must have a minimum air reservoir capacity in litres equal to three times the maximum mass in tonnes carried by the trailer axles.

### 5.0

#### *Exemptions for power-driven vehicles which are equipped to tow trailers*

- 5.1 Power-driven vehicles fitted with manually operated push/pull valves are exempt from 4.3.1.(a) where the following requirements are met:
- The valve applying the combination's park brakes (the button must be coloured yellow).
  - The valves used to apply the park brakes on the towing vehicle or trailer separately are adequately guarded to prevent accidental operation during an emergency.
- 5.2 If the requirements of clauses A.3.4.(a), A.3.4.(b), A.3.5.(c) and A.8.1 cannot be met, the Certifier may apply to the [Agency] for an exemption.

#### *Appendix A*

#### *Distribution of braking among the axles of vehicles and requirements for compatibility between towing vehicle and trailer.*

##### A.1.0 General

- A.1.1 This Appendix relates to the braking forces which are generated by friction in the foundation brake. Those braking forces which are applied through the vehicle's transmission do not form part of this Appendix.
- A.1.2 The requirements of this Appendix must be met by vehicles when laden to their brake Code mass.

A.1.3 A power-driven vehicle that is not permitted to tow a trailer with a GVM of more than 3500 kg, is exempt from the requirements of this Appendix provided the vehicle is certified to an alternative standard that is acceptable to the [Agency] and:

- the distribution of a vehicle's weight between its axles, when loaded to its GVM, is within 10% of the vehicle's original certified axle loads; and
- the vehicle is fitted with load sensing or recognised anti-lock braking devices.

A.1.4 No device must be fitted in a vehicle cab which could allow the driver to alter the vehicle's braking balance in respect to the requirements of this Appendix

### A.2.0 Symbols

E = wheelbase (metres)

$f_i = T_i/N_i$ , adhesion utilisation curves for axle  $i$  (See note 1)

$g$  = acceleration due to gravity ( $9.81\text{m/s}^2$ )

$h$  = height of centre of gravity of the laden vehicle (metres)

$h_o$  = height of centre of gravity of drawing vehicle (metres)

$h_s$  = height of the transverse pivot axis of the coupling on which the semi-trailer rests (metres)

$i$  = axle identifier counting from the front of vehicle, e.g. 1 for the front axle, 2 for the second axle, etc

$J$  = deceleration of the vehicle ( $\text{m/s}^2$ )

$M$  = weight of vehicle (BCM) (tonnes)

$M_i$  = reaction normal to road surface on axle  $i$  under static conditions (tonnes)

$MM$  = total normal static reaction between road surface and wheels of drawing vehicles for trailer or semi-trailer (tonnes)

$MM = M_o + M_{so}$  (tonnes)

$M_o$  = unladen mass of vehicle (tonnes)

$M_s = M_{so} (1 + 0.45z)$  (used only in Section A.3.5.)

$M_{so}$  = difference between the maximum laden mass of the drawing vehicle and its unladen mass (tonnes)

$N_i$  = vertical reaction of road surface on axle  $i$  under normal braking (tonnes)

$P_m$  = pressure at coupling head of control line (kPa)

$MR$  = total normal static reaction normal to road surface on all wheels on laden trailer or semi-trailer (tonnes)

$T_i$  = force exerted by the brakes on axle  $i$  under normal braking conditions on the road (kN)

$TM$  = sum of braking forces at the periphery of all wheels of drawing vehicles for trailers or semi-trailers (kN), the expression  $TM/MM$  is referred to as a braking ratio

$TR$  = sum of braking forces at the periphery of all wheels of a trailer or semi-trailer (kN). The expression  $TM/MM$  is referred to as a "Braking Ratio"

Note 1 Adhesion utilisation curves of a vehicle are the curves of adhesion utilised by each axle  $i$  plotted against the braking ratio of the vehicle for a specific load condition.

Note 2 For semi-trailers,  $z$  is the braking force divided by the static weight on the semi-trailer axle(s).

### A.3.0 Requirements for power-driven vehicles

A.3.1 Two axle vehicles

- a) The following relationship must hold for  $f$  for values of  $z$  between 0.2 and 0.8:

$$f_i \leq \frac{z}{0.85}$$

- b) For two axled vehicles, the curve of adhesion utilisation ( $f_i$ ) for the front axle must be above that of the rear axle, for the range of values of  $z$ , between  $z = 0.15$  and  $z = 0.30$ . This condition is satisfied when the adhesion utilisation curve for each axle passes between the two lines parallel to  $f_i z$  (line of ideal adhesion utilisation) and defined by  $f_i = z \pm 0.08$ , as shown in Diagram 1.
- c) To verify the requirements of A.3.1 and A.3.2, the vehicle manufacturer must produce the adhesion utilisation curves for the front and rear axles, as calculated by the formulas:

$$f_1 = \frac{T_1}{N_1} = \frac{T_1}{M_1 + \frac{zhM}{E}}$$

$$f_2 = \frac{T_2}{N_2} = \frac{T_2}{M_2 + \frac{zhM}{E}}$$

- d) Where there are several different loading options for a particular vehicle, the maximum permissible loading on the front axle must be the one used in calculations.

A.3.2 In power-driven vehicles designed to tow trailers and fitted with compressed air brake systems, at each full service brake application, the air line pressure measured at the brake coupling must be:

- supply line - between 650 and 800 kPa; and
- control line - between 600 and 750 kPa.

Irrespective of the load of the vehicle, these pressures must be readily measurable at the brake coupling of the towing vehicle.

A.3.3 Vehicles with more than two axles

- a) The curve of adhesion utilisation ( $f_i$ ) for at least one of the front axles must be above that of at least one of the rear axles, for the range of values of  $z$ , between  $z = 0.15$  and  $z = 0.30$ . This condition is satisfied when the adhesion utilisation curve for each axle ( $f_i$ ) passes between the two lines parallel to  $f_i = z$  (line of ideal adhesion utilisation) and defined by  $f_i = z \pm 0.08$  as shown in Diagram 1.

- b) When calculating the adhesion utilisation ( $f_i$ ) for individual axles, where:

- braking has little effect on axle loadings because of the suspension design (brake reactivity), such transient effects on axle loads may be neglected; and
- braking has a significant effect on the axle load distribution, the Certifier must verify that no wheels on the vehicle lock up at a deceleration of  $4.5 \text{ m/s}^2$  during a road test using the service brake, with the vehicle loaded to BCM.

A.3.4 Vehicles other than powered vehicles towing semi-trailers

For vehicles:

- a) Those fitted with an air brake system, the permissible relationship between the ratios TR/MR or TM/MM and the air pressure at the brake coupling ( $p_m$ ) must be within the shaded area shown in Diagram 2.
- b) Those first registered in New Zealand before 1 July 1991 may be set up to comply with Diagram 3 as an alternative to Diagram 2, only after the consent of the [Agency] has been obtained.

A.3.5 Towing vehicles for semi-trailers

- a) The dynamic load of the semi-trailer on the drawing vehicle is represented by a static weight  $M_s$ , which must be applied at the coupling kingpin and be equal to:

$$M_s = M_{so}(I + 0.45z)$$

- b) In calculations of the effect of load transfer, the following value must be taken for  $h$ :

$$h = \frac{h_o.M_o + h_s.M_s}{M}$$

where

$$M = M_o + M_s$$

- (c) In the case of vehicles fitted with air brake systems, the graph of the required relationship between the braking ratio (TM/MM) and the brake coupling pressure ( $p_m$ ) must be within the shaded area shown in Diagram 3.

#### A.4.0 Requirements for full trailers

A.4.1 The requirements set out in clauses A.3.1 through to A.3.4 inclusive must apply to full trailers.

#### A.5.0 Requirements for semi-trailers

A.5.1 For semi-trailers fitted with compressed air brakes, the graph of the required relationship between the braking ratio (TR/MM) and the brake coupling pressure ( $p_m$ ) must lie within the shaded area shown in Diagram 2.

A.5.2 The requirement of clause A.3.3.(b) must be applied to vehicles with more than one axle if the suspension geometry affects the axle load distribution during brake applications (brake reactive suspensions).

A.5.3 If the semi-trailer is itself a towing vehicle for a second semi-trailer (i.e. the first semi-trailer in a B-train), the semi-trailer must meet the requirements specified in clause A 3.5, when laden to its GVM.

#### A.6.0 Requirements for simple trailers

Simple trailers must be subject to the requirements of A.5.

#### A.7.0 Load sensing devices

A.7.1 In any air brake system, it is recommended that the load sensing devices do not modulate the pressure below 70 kPa.

A.7.2 Where a Coded vehicle is fitted with a load sensing facility in its braking system:

- it must meet the Code's performance requirements; and
- the Certifier must be satisfied that under normal conditions the braking performance of its braking system will not be adversely affected when operating with a Coded vehicle not fitted with load sensing, in both the laden and unladen condition. The Certifier must be able to demonstrate (refer to 3.1.3(b) to the [Agency], if requested, that the braking performance of either vehicle has not been jeopardized.

Where there is doubt as to possible adverse effects on braking performance, the load sensing system should be fixed at the level required by the Code's calculations for the laden condition.

A.7.3 In the event of a failure, the control of these devices must be capable of meeting the following requirements:

- stop the vehicle under the conditions specified for emergency braking.
- achieve a pressure at the coupling head of the control line within the range specified in A.3.2. in power-driven vehicles designed to tow a trailer fitted with air brakes.

#### A.8.0 Threshold pressure tests for combination vehicles fitted with air brake systems

A.8.1 The braking at the wheels must commence at a pressure between 55 kPa and 80 kPa, measured in the control line, at the brake coupling.

Braking is considered to have started when a torque of 100 Nm is first achieved at the wheel of least advantage.

For vehicles (including trailers) equipped to tow a trailer(s), the braking at all the vehicle's wheels must commence at a pressure between 50 kPa and 85 kPa. This pressure measurement must be made at the coupling head of the control line of the towing vehicle.

Exemptions from this clause can only be obtained from the [Agency].

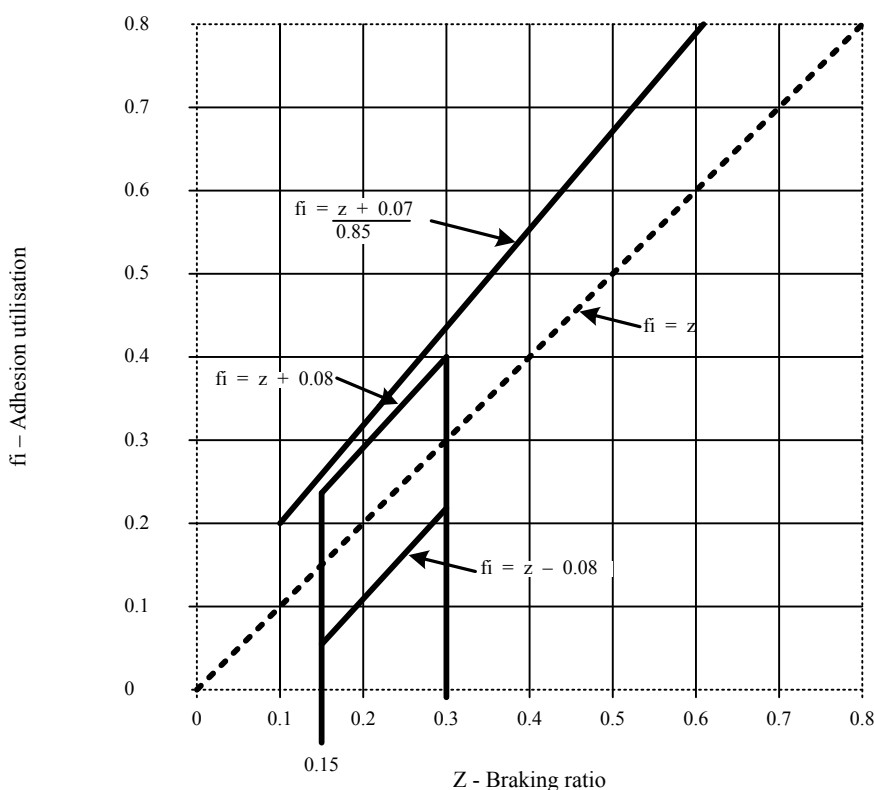

**Diagram 1**

*Adhesion utilisation criteria (See A.3.1)*

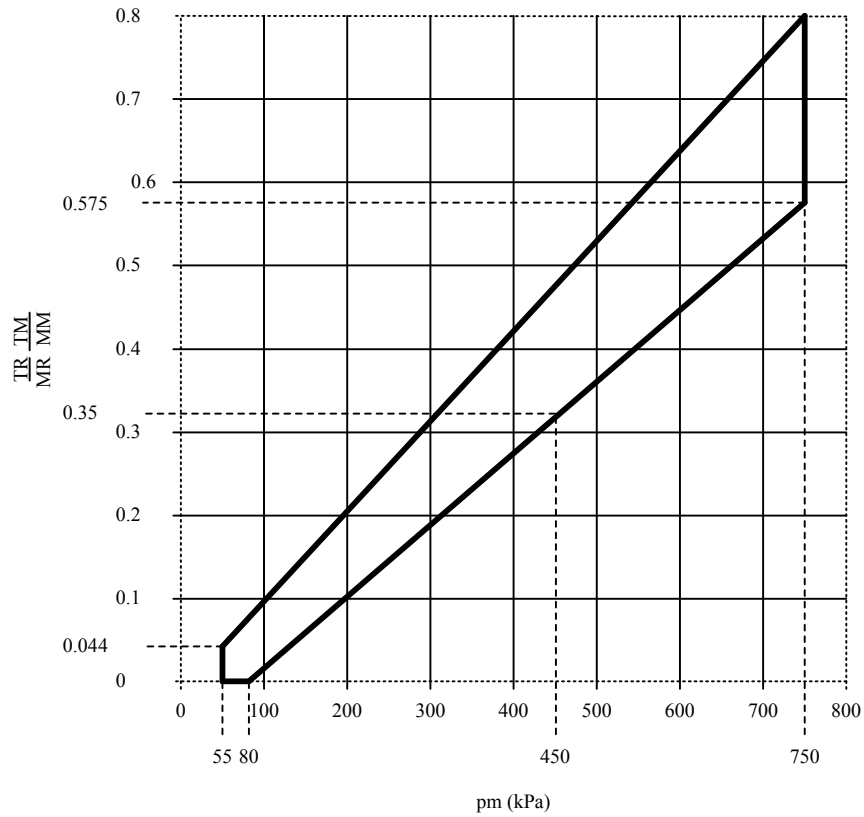

**Diagram 2: Towing vehicles, semi-trailers and full trailers**

The shaded area defines the permissible relationship between the braking ratio and the air pressure in a towing vehicle's compressed air braking systems, as measured at the coupling head. (See Clauses A.3.4.1 and A.5.1)

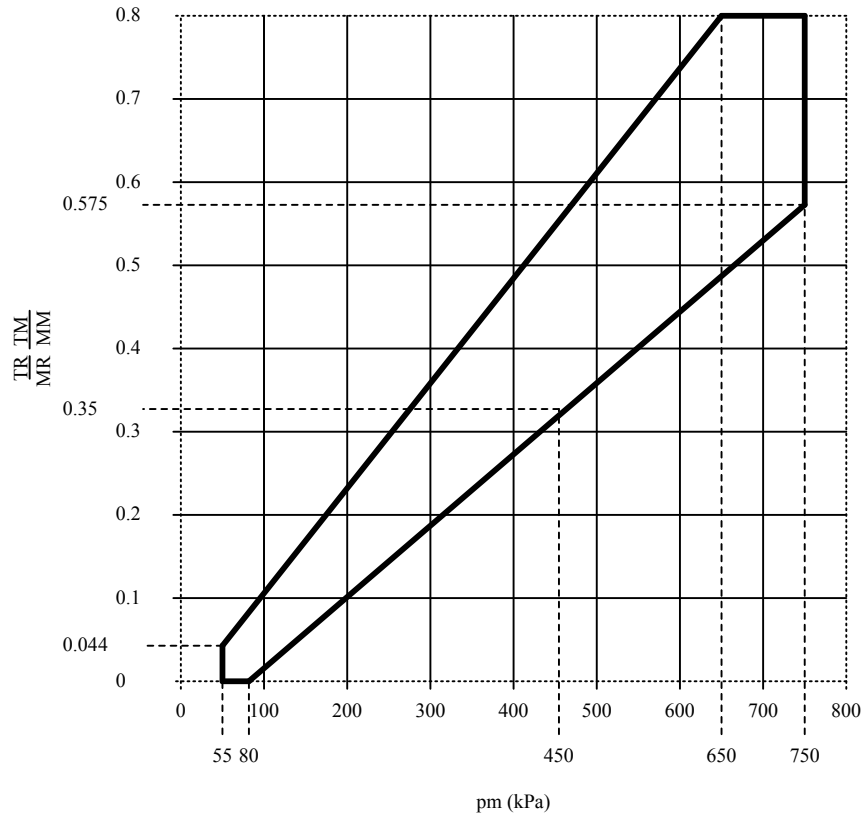

**Diagram 3: Towing vehicles for semi-trailers**

The shaded area defines the permissible relationship between the braking ratio and the air pressure in a towing vehicle's compressed air braking systems, as measured at the coupling head. (See A.3.5)

*Note: this diagram can only be used with the Director's permission.*

### Appendix B

*The standard procedure for measuring the response time on vehicles equipped with compressed air brakes (based on ECE 13 Annex 6)*

#### B.1.0 General

B.1.1 This procedure is not mandatory and should be used only where there is doubt surrounding the timing of a vehicles air brake system. In the event, response times are required to be measured, this procedure should be closely followed.

B.1.2 The response times of the brake system should be determined on the stationary vehicle. The air pressure is to be measured and recorded at the:

- air inlet to the brake chamber of the least favourably placed brake; and
- brake coupling, (if fitted).

During the test, the length of free stroke in the brake cylinders on the axles should be that specified by the Certifier. The measured response times should be rounded to the nearest tenth of a second.

#### B.2.0 Power-driven vehicles

B.2.1 At the beginning of each test, the reservoir air pressure should be equal to:

- for governed compressors, the pressure at which the governor restores the feed to the system; or
- for compressors not fitted with governors, the pressure in the air reservoir at the beginning of each test should be 90% of the pressure specified by the Certifier.

B.2.2 The time taken from the moment of

- initiation of a full brake application to when the pressure in the brake chamber reaches 75% of its final value (should not exceed 0.6 seconds); and
- release of the fully depressed brake pedal to the moment when the brake air pressure reaches 25% of its initial value (should not exceed 0.6 seconds).

B.2.3 In the case of power-driven vehicles being equipped to tow trailers, the response time should be measured at the brake coupling. For this test, a pressure vessel with a capacity of  $385 \pm 5 \text{ cm}^3$  should be connected to the supply and control lines separately, at the brake coupling. The volume of this vessel equates to the internal volume of a pipe 2.5 m long with an internal diameter of 13 mm and under a pressure of 650 kPa.

In the case of towing vehicles of semi-trailers, these should be equipped with flexible pipes (suzies) for connection to the semi-trailers, and the brake couplings should be fitted to the end of these flexible pipes. The measured response times may be rounded up to the nearest one tenth of a second, but should not exceed the following maximum permitted response times:

- 0.40 seconds from the initiation of a full brake application to the moment when the pressure measured at the brake coupling of the control line reaches 75% of its final value;
- 0.60 seconds from the initiation of a release of the fully depressed brake pedal to the moment when the brake coupling air pressure reaches 25% of its initial value.

#### B.3.0 Trailers, including semi-trailers

B.3.1 The trailer's response time should be measured without the towing vehicle being connected. To replace it, a simulator that pneumatically represents the towing vehicle should be provided. The simulator is connected to the trailer's control line and supply line at the brake coupling.

B.3.2 The air pressure in the supply line should be:

$$650 \begin{matrix} + 15 \\ - 0 \end{matrix} \text{ kPa}$$

B.3.3 The simulator used should:

a) contain the following features:

- a reservoir with a capacity of 30 litres;
- an orifice between 4.0 mm to 4.3 mm diameter fitted in the outlet of the braking;
- a length of a pipe from the orifice to the brake coupling, with a capacity of  $385 \pm 5 \text{ cm}^3$  (equivalent to the volume of air contained in a pipe 2.5 m long and 13 mm internal diameter and pressurized to 650 kPa); and
- a brake control valve so designed that its performance is unaffected by the presence of the tester.

The simulator's reservoir should be recharged to 650 kPa before each test and not during the test.

The control line pressures referred to in B.3.3(b) should be measured immediately downstream of the orifice.

b) Be capable of being adjusted through the choice of a suitably sized orifice in (refer clause B.3.3(a)) so that when receiver of:

- $385 \pm 5 \text{ cm}^3$  capacity is connected, it will take  $0.2 \pm 0.01$  seconds for the system pressure to increase from 65 to 490 kPa (10% and 75% respectively of the nominal pressure of 650 kPa); or
- $1155 \pm 15 \text{ cm}^3$  capacity is substituted for the smaller one, the pressure should increase from 65 to 490 kPa without further adjustment in  $0.38 \pm 0.02$  seconds.

Between these two pressure values the pressure should increase approximately linearly.

The receivers should be connected to the brake coupling without using flexible pipes and the receivers and pipes should have an internal diameter of not less than 10 mm.

- c) The circuit layouts in Diagram 1 in this Appendix give an example of the correct arrangement of the simulator for setting and use.

B.3.4 The time difference between the pressure in the control line and the trailer actuator should not exceed the following times:

- 0.40 seconds from the time the rising control line pressure reaches 65 kPa and the pressure in the trailer brake actuator reaches 75% of the asymptotic value;
- 0.60 seconds from the time the falling control line pressure reaches 490 kPa and the pressure in the trailer brake actuator reaches 25% of its initial value.

B.3.5 In the case of semi-trailers equipped to tow a second semi-trailer and for the purposes of this test, a pressure vessel with a capacity of  $385 \pm 5 \text{ cm}^3$ , should be connected to the control line at the rear-most brake coupling. The measured response times may be rounded up to the nearest one tenth of a second, but should not exceed the following maximum permitted times:

- 0.40 seconds from the time the rising control line pressure reaches 65 kPa and the pressure in the rear-most brake coupling reaches 75% of the asymptotic value;
- 0.60 seconds from the time the falling control line pressure reaches 490 kPa and the pressure at the rear-most brake coupling reaches 25% of its initial value.

#### B.4.0 Part-pneumatic brake systems

B.4.1 For part-pneumatic brake systems, the requirements of Paragraphs B.1, B.2 and B.3 that refer to:

- the brake coupling should be met; and
- the least favourably placed actuator should apply to the least favourably placed pneumatic device which acts on the non-pneumatic part of the brake system.

Diagram 4 Typical simulator circuits to determine the response times of a vehicle's braking system. The key to the abbreviations used:

A = Supply connection with shut off valve

C1 = Pressure switch in the simulator, set at 65 kPa and 490 kPa

C2 = Pressure switch to be connected to the brake actuator of the trailer, to operate at 75 of the asymptotic pressure in the brake actuator CF

CF = Brake actuator

L = Line from orifice O up to and including its coupling head TC, having an internal volume of  $385 \pm 5 \text{ cm}^3$  under a pressure of 650 kPa

M = Pressure gauge

O = Orifice with a diameter of not less than 4.00 mm and not more than 4.30 mm

PP = Pressure test connection

R1 = 30 litre air receiver with a drain valve

R2 = Calibrating receiver including its coupling TC, to be  $385 \pm 5 \text{ cm}^3$

R3 Calibrating receiver including its coupling TC, to be  $1155 \pm 15 \text{ cm}^3$

RA = Shut off valve

TA = Supply line coupling

TC = Control line coupling

V = Brake control valve

VRU = Relay valve

#### Diagram 4

*Setting the Simulator*

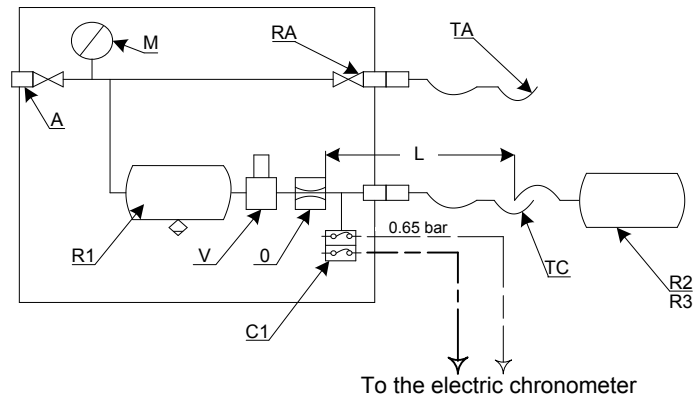

*Testing the trailer*

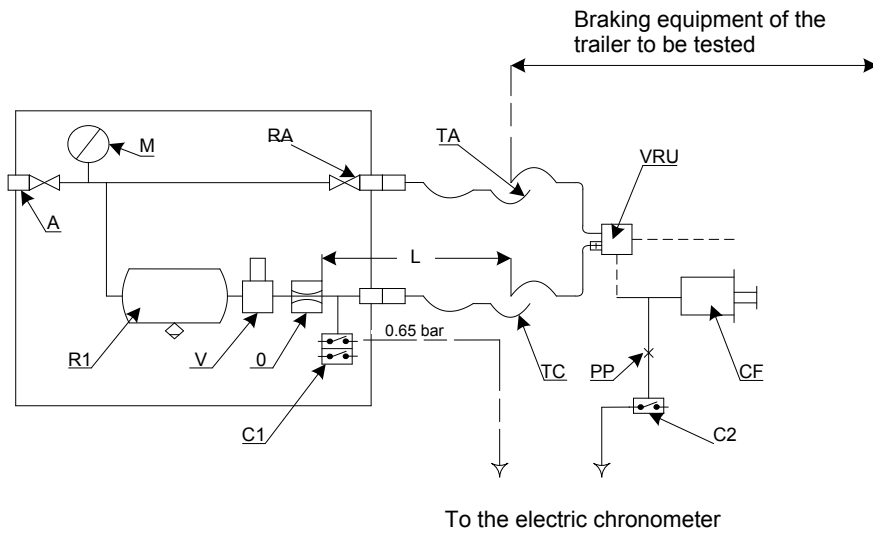

*Appendix C**Statement of Compliance with the New Zealand Heavy Brake Code***Vehicle description**

Make: \_\_\_\_\_ Model: \_\_\_\_\_

VIN: \_\_\_\_\_

**Vehicle dimensions**

Height of vehicle's unladen COG (m): \_\_\_\_\_

Height of payload's COG (m): \_\_\_\_\_

Wheelbase (m): \_\_\_\_\_

Distance of payload's COG from front axle: \_\_\_\_\_

Height of fifth wheel\* (m): \_\_\_\_\_

**Vehicle weights**

Unladen axle weights

Front axle(s) (kg): \_\_\_\_\_ Rear axle(s) (kg): \_\_\_\_\_

**Suspension details**

Front suspension type: \_\_\_\_\_ Rear suspension type: \_\_\_\_\_

(reactive/unreactive)

(reactive/unreactive)

**Brake system air pressure**

Maximum operating pressure (kPa) [Pg]: \_\_\_\_\_

Governor cut in pressure (kPa) [Pg]: \_\_\_\_\_

Time taken for air pressure to rise from Pg to Pm (secs): \_\_\_\_\_

**Brake system details**

Axle	Coupling Producing 100Nm Torque	Pressure at Brake Force kN/kPa @ Brake Chamber	Tyre size	Friction materials		
				Make	Identifier /Grade	Design coefficient of friction
1						
2						
3						
4						
5						

Axle	Brake type	Drum diameter (mm)	Chamber area (mm)	Length of slack adjuster (mm)	Spring brake force (kN)
1					
2					
3					
4					

Truck or tractor (towing vehicle)		
Valve type	Make	Model
Treadle		
Primary Circuit Relay		
Secondary Circuit Relay		
Trailer Control Relay		
Load Sensing		
Quick Release		
Park Brake		
Trailer Hand Control		

Trailer (towed vehicle)		
Valve type	Make	Model
Relay 1		
Relay 2		
Spring Brake		
Quick release valve		
Pilot 1		

Documentation required to support Statements of Compliance with the New Zealand Heavy Brake Code, to be made available to the Statutory Authority on request, must include all calculations and test reports.

---

**Confirmation of compliance**

I confirm that the vehicle identified on page 1 of this Statement of Compliance complies with all relevant requirements of the current New Zealand Heavy Vehicle Brake Code.

Date: \_\_\_\_\_ Signed: \_\_\_\_\_

---

**Certifier's identification**

Name: \_\_\_\_\_

Phone (bus): \_\_\_\_\_ Fax (bus): \_\_\_\_\_

Postal address: \_\_\_\_\_

Position: \_\_\_\_\_

---

**Confirmation of continued compliance of modification**

I confirm the brake system of the vehicle identified on page 1 of this Statement of Compliance as modified by myself, continues to comply with all the relevant requirements of the current New Zealand Heavy Vehicle Brake Code.

Date: \_\_\_\_\_ Signed: \_\_\_\_\_

Certifier's identification \_\_\_\_\_

Name: \_\_\_\_\_

Phone (bus): \_\_\_\_\_ Fax (bus): \_\_\_\_\_

Postal address: \_\_\_\_\_

Position: \_\_\_\_\_

*Appendix D*

*Pressure test connections for compressed air braking systems*

Dimensions of the typical connection

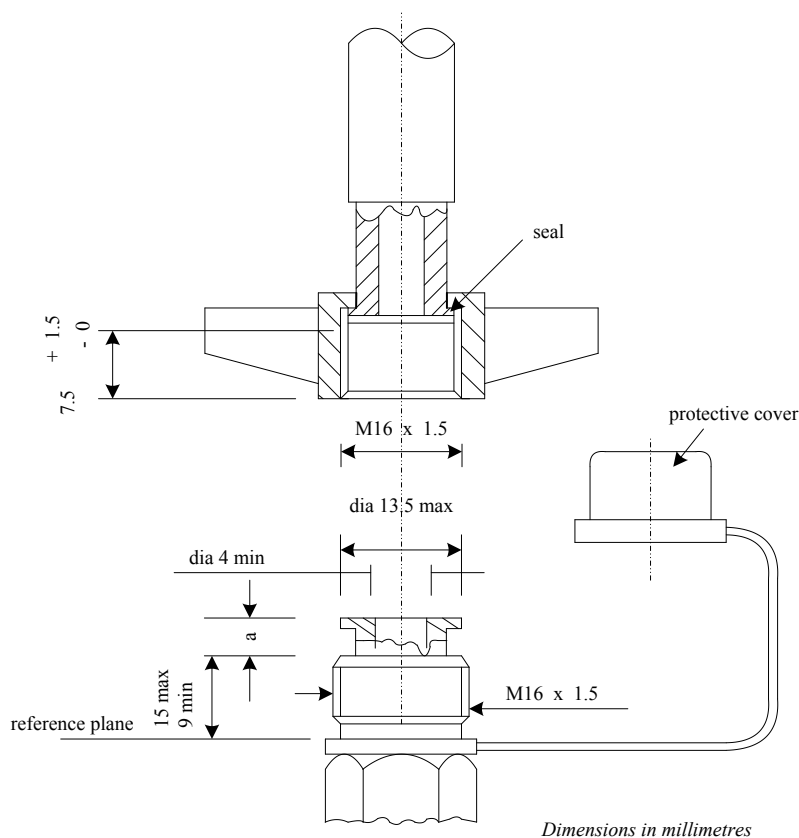

valve position	dimension "a"
closed	5 mm
open	3 mm

Dimensions not specified are to be chosen according to the application.

Seals and covers shall withstand petroleum products.

### Appendix E

#### Provisions for air compressors and air receivers (based on ECE 13, Annex 7).

#### Compressed-air braking systems

##### E.1.0 Capacity of air receivers

###### E.1.1 General

Vehicles on which the braking device requires the use of compressed air must be equipped with air receivers of a capacity that meets the requirements of E.1.2 and E.1.3 below.

However the air receivers are not required to be of a prescribed capacity if the brake system is capable of achieving a braking performance at least equal to the statutory requirement for emergency braking.

In verifying compliance with the requirements of E.1.2 and E.1.3 below, the brakes must be adjusted so that all excessive clearances, within the foundation brakes, has been eliminated as is practical.

###### E.1.2 Power-driven vehicles

The air brake receivers of power-driven vehicles must be of such a capacity that after eight full-strokes of the service brake control, the pressure remaining in the air brake receiver must be not less than the pressure required to obtain the specified secondary (emergency) braking performance.

For the purposes of this test, the following requirements must be met:

- The initial pressure in the air receiver or receivers must be that specified by the manufacturer so that the prescribed performance of the service braking system is achieved.
- All auxiliary air receivers must be isolated.
- In the case of motor vehicles equipped to tow a trailer or semi-trailer, the feed line must be stopped and a 0.5 litre air receiver must be connected to the control line. This receiver must be vented before each braking operation. After the test referred to in E.1.2. above, the air pressure in the control line must not fall below a level equivalent to one-half of the figure obtained at the first brake application.

###### E.1.3 Trailers and semi-trailers

The air receivers fitted to trailers and semi-trailers must be of sufficient capacity to allow eight full-strokes of the drawing vehicle's service brakes (without the air pressure falling below one-half of the pressure measured at the first brake application).

Testing must comply with the following requirements:

- a) The pressure in the air receivers at the beginning of each test must be the maximum pressure specified by the manufacturer.
- b) The air supply line and any auxiliary air receivers must be isolated.
- c) The air receiver must not be replenished during the test.
- d) At each brake application, the pressure in the control line must be the maximum pressure specified by the manufacturer.

### **E.2.0 Capacity of compressors**

#### **E.2.1 General**

The compressors must meet the requirements set forth in the following Paragraphs.

#### **E.2.2 Definitions**

$p_1$  is the pressure in bars, corresponding to 65% of the pressure  $p_2$  defined below

$p_2$  is the pressure in bars as specified by the manufacturer and referred to above

$T_1$  is the time required for the relative pressure to rise from 0 to  $p_1$

$T_2$  is the time required for the relative pressure to rise from 0 to  $p_2$

#### **E.2.3 Conditions of measurement**

In all cases the speed the compressor is run at for the purposes of this test must be the same as would be obtained when the engine was running at the speed corresponding to its maximum power or at the speed permitted by the engine governor.

During the tests to determine the time  $T_1$  and the time  $T_2$ , the auxiliary air reservoirs must be isolated.

In the case of a power-driven vehicle which was intended to tow a trailer, the trailer must be represented by an air reservoir whose capacity and maximum pressure  $p$  is given by:

$$p.V = 20.R$$

where:

$p$  = maximum pressure as supplied through the towing vehicle's air supply (bars)

$V$  = volume of the reservoir simulating the presence of the trailer (litres)

$R$  = sum of the permissible maximum axle load carried by the axles of the trailer or semi-trailer (tonnes)

#### **E.2.4 Interpretation of results**

Time  $T_1$  recorded for the least favoured reservoir must not exceed:

- (a) 3 minutes for vehicles not fitted to tow a trailer(s) or semi-trailer(s); or
- (b) 6 minutes for vehicles fitted to tow a trailer(s) or semi-trailer(s).

The time  $T_2$  recorded for the least favoured reservoir must not exceed

- (a) 6 minutes for vehicles not fitted to tow a trailer(s) or semi-trailer(s); or
- (b) 9 minutes for vehicles fitted to tow a trailer(s) or semi-trailer(s).

#### **E.2.5 Additional test**

If the power-driven vehicle is equipped with one or more auxiliary air reservoirs having a combined capacity exceeding 20% of the total compressed air storage capacity on the vehicle, an additional test will be required. For the duration of this test no change in the operation of the valves controlling the filling of the auxiliary air reservoirs is permitted.

This test consists of measuring the time,  $T_3$  taken to raise the pressure of the least favoured air reservoir from a pressure of 0 bars to  $p_2$  bars is less than:

- (a) 8 minutes for vehicles not fitted to tow a trailer(s) or semi-trailer(s); or
- (b) 11 minutes for vehicles fitted to tow a trailer(s) or semi-trailer(s).

#### **E.2.6 The test must be performed in the conditions prescribed in E.2.3.**

### **E.3.0 Pressure connections**

E.3.1 To facilitate the periodic inspection of vehicles already in use on the road, a pressure connection must be fitted close to the least favourably placed air reservoir.

E.3.2 The pressure connection must comply with Appendix D to this Code.

## **Schedule 5**

### **New Zealand Heavy-vehicle Brake Specification**

(cl 1. to cl 12.)

#### **1. Application**

1.1 This Specification is applicable to vehicles as required in Land Transport Rule: Heavy-vehicle Brakes 2006 (Rule 32015) (**the Rule**).

- 1.2 A vehicle that is required to comply with the requirements in this Specification must also comply with all other requirements as specified for the vehicle or its class in the Rule.
- 1.3 A vehicle that is not required to comply with this Specification may also be manufactured or modified in accordance with the technical requirements in the Specification.

## 2. Additional equipment requirements

- 2.1 Equipment or components fitted to a vehicle as part of its brake must be suitable for automotive application.
- 2.2 Equipment or components fitted to the brake of a vehicle must be appropriate, in respect of their nominal size, operational and performance characteristics and other relevant features, for the brake of the vehicle.
- 2.3 Brake components must be fitted and adjusted correctly, having regard to the manufacturer's Specification.

## 3. Additional system requirements for air brakes

- 3.1 An air brake of a powered vehicle must have two independent service-brake circuits.
- 3.2 If a vehicle is fitted with a spring-operated parking brake that is normally released by compressed air, the simultaneous application of the service brake and parking brake must not result in a compounded brake force on the axle or axles on which the parking brake acts. This may be referred to as an 'anti-compounding' requirement.
- 3.3 The air brake of a vehicle must be fitted with the additional equipment in 3, as applicable.
- 3.4 A pressure test connector as specified in Appendix D of the *New Zealand Heavy Vehicle Brake Code, Second edition (1997)* must be fitted to a vehicle as follows:
- to the inlet of at least one brake chamber, which is in the least favourable position, of the service brake on each axle set; and
  - to the upstream and downstream side of all valves that are fitted to modulate the pressure of the compressed air for the actuation of the service brake, including, but not limited to, ratio valves, load sensing valves and pressure limiting valves.
- 3.5 A drain valve must be fitted to the lowest point of each brake reservoir, specifically, the reservoirs of the service brake and park brake, and including the so-called "wet tank".
- 3.6 An automatic drain valve must have a means of manual operation.
- 3.7 The compressed-air reservoir of auxiliary equipment connected to the air brake must also be fitted with a drain valve at the lowest point of the reservoir, if the manufacturer of the auxiliary equipment requires or recommends this.
- 3.8 A drain valve fitted to an air-brake reservoir or to the reservoir of auxiliary equipment must be capable of being operated by a person standing beside the vehicle, without the need for a pit or hoist.
- 3.9 If an air dryer is fitted to an air brake, the compressor capacity of the air brake must be sufficient to ensure the correct operation of the air dryer, having regard to the air dryer manufacturer's recommendations.

## 4. Additional requirements for powered vehicles not used to tow heavy trailers

- 4.1 A two-axle powered vehicle that is not fitted with a towing connection to tow a heavy trailer must comply with the requirements in 4.1.1 and 4.1.2.
- 4.1.1 For a vehicle in 4.1, the following relationship must hold for the adhesion utilisation ( $f_i$ ) between a braking ratio ( $z$ ) of 0.15 g and 0.8 g for both the front and rear axle:

$$f_i \leq \frac{z + 0.07}{0.85}$$

For a vehicle in 4.1, when  $0.15 \leq z \leq 0.3$ , the adhesion utilisation:

- 4.1.2 For a vehicle in 4.1, when  $0.15 \leq z \leq 0.3$ , the adhesion utilisation:
- of the rear axle must not exceed that of the front axle; and
  - of any axle must not be greater than  $z + 0.08$ ; and
  - of any axle must not be less than  $z - 0.08$ .
- 4.2 A powered vehicle that has more than two axles and does not have a towing connection to tow a heavy trailer must comply with the requirements in 4.2.1 to 4.2.3.
- 4.2.1 For a vehicle in 4.2, the relationship in 4.1.1 must hold for all axles of the vehicle between a braking ratio of 0.15 g and 0.8 g.
- 4.2.2 For a vehicle in 4.2, and between 0.15 g and 0.3 g braking ratio ( $z$ ), the adhesion utilisation for any of the axles must be within the limits specified in 4.1.2.
- 4.2.3 For a vehicle in 4.2, and between 0.15 g and 0.3 g braking ratio ( $z$ ), the adhesion utilisation of at least one of the rear axles must not exceed the adhesion utilisation of the front axles or that of at least one of the front axles; and that rear axle must be:
- the one that carries greater load if the rear axles are fitted with non-reactive suspension; or
  - for axles with reactive suspension that carry a similar load, the axle to which some load is transferred during braking due to the reactive suspension; or
  - for axles carrying a similar load and fitted with air suspension, the foremost axle in the axle set.
- 4.3 The requirements in 4. must be complied with at any load condition, and must be demonstrated by means of calculation carried out, at least, for the vehicle when unladen and when laden to its GVM. However, a vehicle that is fitted with ABS must only comply with this requirement, without relying on the operation of such a control device, when loaded to its GVM.
- 4.4 Compliance with the requirements in 4 may be shown by plotting the calculated adhesion utilisation curves for all front and rear axles in a Diagram that also includes the permissible limits for the adhesion utilisation as specified in 4.1.1 and 4.1.2. (See also *Figure 1*, showing permissible limits for adhesion utilisation as a function of braking ratio.)

**5. Additional requirements for air-braked powered vehicles that are used to tow heavy trailers other than semi-trailers**

- 5.1 A vehicle in 5 must also comply with the requirements in 4, as applicable, according to the number of axles of the vehicle.
- 5.2 For a vehicle in 5, the following relationship must hold, when the control line pressure ( $p_m$ ) measured in kPa at the Duomatic or other type coupling connecting the air brake of the towing and towed vehicle is:
- (a) if  $55 \text{ kPa} \leq p_m \leq 750 \text{ kPa}$ , then  $z \leq 0.044 + (p_m - 55) \times 0.756/695$ ; and
  - (b) if  $80 \text{ kPa} \leq p_m \leq 450 \text{ kPa}$ , then  $(p_m - 80) \times 0.35/370 \leq z$ ; and
  - (c) if  $450 \text{ kPa} \leq p_m \leq 750 \text{ kPa}$ , then  $0.35 + (p_m - 450) \times 0.225/300 \leq z$
- 5.3 The requirements in 5.2 must be complied with at any load condition and demonstrated by means of calculation carried out, at least, when the vehicle is unladen and when laden to its GVM. However, a vehicle that is fitted with ABS must only comply with this requirement, without relying on the operation of such a control device, when loaded to its GVM.
- 5.4 Compliance with the requirements in 5 may be shown by plotting:
- (a) the calculated adhesion utilisation curves as specified in 4; and
  - (b) the calculated braking ratio as the function of control-line pressure and the permissible limits specified in 5.2.
- (See also *Figure 2* showing permissible braking ratio limits as a function of control-line pressure.)

**6. Additional requirements for air-braked full trailers**

- 6.1 A full trailer must comply with the requirements both in 4, as applicable to the vehicle according to the number of axles fitted to the trailer, and with the requirements in 5.2.
- 6.2 The requirements in 6 must be complied with at any load condition, and demonstrated by means of calculation carried out, at least, when the vehicle is unladen and when laden to its GVM. However, a vehicle that is fitted with ABS must only comply with this requirement, without relying on the operation of such a control device, when loaded to its GVM.
- 6.3 Compliance with the requirements in 6 may be shown in the same way as in 5.4.

**7. Additional requirements for air-braked powered vehicles used to tow semi-trailers**

- 7.1 A vehicle in 7 must also comply with the requirements in 4 as applicable according to the number of axles of the vehicle, and also with the requirements in 5.2.
- 7.2 Despite 7.1, the braking ratio may exceed the limits specified in 5.2(a) if written permission has been obtained from the [Agency] for the vehicle, but, in such a case, the following relationship must hold:  
when  $55 \text{ kPa} \leq p_m \leq 650 \text{ kPa}$ , then  $z \leq 0.044 + (p_m - 55) \times 0.756/595$   
(See also *Figure 3*, showing permissible braking ratio as a function of control-line pressure.)
- 7.3 The requirements in 7 must be complied with at any load condition and demonstrated by means of calculations, carried out, at least, when the vehicle is unladen and when loaded to its GVM. However, a vehicle that is fitted with ABS must only comply with this requirement, without relying on the operation of such a control device, when loaded to its GVM.
- 7.4 When compliance with the requirements in 7.1 is demonstrated by calculation, it must be taken into account that the vehicle carries a portion of the mass of the semi-trailer and that portion is increasing when the braking ratio is increasing.
- 7.5 For the purpose of calculations to demonstrate compliance with the requirements in 4 and 5 or 7.2, the factors in 7.5.1 to 7.5.4 must be taken into account.
- 7.5.1 The mass of the vehicle in an unladen condition, when a semi-trailer is not attached to the vehicle, is  $M_o$ .
- 7.5.2 The mass of the vehicle, when an unladen semi-trailer is attached, must be calculated as follows:  
 $M_{su} = M_o + 0.15 + M_{so}$ , where:  
 $M_{so}$  is the permissible maximum load on the fifth wheel (or other type of coupling by which the semi-trailer is attached). It is the difference between the GVM and  $M_o$ .
- 7.5.3 The mass of the vehicle, when a fully laden semi-trailer is attached, must be calculated as follows:  
 $M_s = M_o + M_{so} \times (1 + 0.45z)$
- 7.5.4 When a calculation is carried out for a partially laden vehicle, the load on the fifth wheel may be calculated assuming a linear correlation between the static and dynamic load on the coupling by which the semi-trailer is connected. (For example, if the static load on the fifth wheel is half of the permitted maximum load,  $M_{so}$ , then at any braking ratio,  $z$ , the dynamic load is:  
 $M_{s0.5} = M_o + 0.5 \times M_{so} \times (1 + 0.45z)$ )
- 7.6 Compliance with the requirements in 7 may be shown by plotting the calculated braking ratio as a function of control-line pressure and the permissible limits specified in 5.2 or 7.2 as applicable. (See also *Figure 2* and *Figure 3*)

**8. Additional requirements for air-braked semi-trailers that are used to tow another semi-trailer (first semi-trailer of a B-train)**

- 8.1 A vehicle in 8 must comply with the requirements in 4, for the adhesion utilisation and the requirements in 5.2, for the braking ratio.
- 8.2 The requirements in 8.1 must be complied with at any load condition and demonstrated by means of calculation. However, a vehicle that is fitted with ABS, must only comply with this requirement, without relying on the operation of such a control device, when loaded to its GVM.
- 8.3 The calculation in 8.2 must be carried out, at least, for the unladen condition and when the vehicle is loaded to the GVM, however, for the purpose of calculations the mass that is carried on the axle set of the semi-trailer must be taken as follows:
- (a) for an unladen vehicle to which no other semi-trailer can be attached, the load on the axle set of the unladen semi-trailer is  $M_{RO}$ ;
  - (b) for an unladen semi-trailer to which another unladen semi-trailer is attached, the unladen mass of the semi-trailer is  $M_{RU}$ ;
  - (c) in a fully-laden condition the maximum permitted load of the axle set is  $M_R$ , as in the Certificate of Loading of the semi-trailer.
- 8.4 Compliance with the requirements in 8 may be shown by plotting:
- (a) *Revoked.*

(b) the calculated braking ratio as a function of control-line pressure and the permissible limits specified in 5.2.

(See also *Figure 2* and *Figure 3*)

#### 9. Additional requirements for air-braked semi-trailers that are not used to tow another semi-trailer

- 9.1 A vehicle in 9 must comply with the requirements in 4 for the adhesion utilisation and the requirements in 5 for the braking ratio.
- 9.2 The requirements in 9.1 must be complied with at any load condition, and they must be demonstrated by means of calculation, except that a vehicle that is fitted with ABS, must only comply with this requirement without relying on the operation of such a control device, when loaded to its GVM.
- 9.3 The calculation in 9.2 must be carried out, at least, when the vehicle is unladen and when laden to its GVM. However, for the purpose of calculating the braking ratio, the mass that is carried on the axle set of the semi-trailer must be taken as follows:
- (a) for an unladen vehicle, the mass that is carried on the axle set is  $M_{RO}$ ;
- (b) for a fully laden vehicle, due to the dynamic load transfer from the semi-trailer to the towing vehicle (MRL):  
 $MRL = M - M_{kp} \times (1 + 0.45z)$ , where:  
 $M$  is the GVM, and  $M_{kp}$  is the static load carried by the kingpin when the vehicle is loaded to its GVM.
- 9.4 Compliance with the requirements in 9 may be shown by plotting:
- (a) *Revoked.*
- (b) the calculated braking ratio as a function of control-line pressure and the permissible limits specified in 5.2.
- (See also *Figure 2* and *Figure 3*)

#### 10. Requirements for the calculations in this Specification

- 10.1 A calculation to demonstrate compliance with the requirements in this Specification must be carried out by using computer software that has been approved by the [Agency].
- 10.2 A calculation may also be carried out manually, i.e., by “longhand” calculation.
- 10.3 For the purpose of calculating the adhesion utilisation of the axles of a two-axle powered vehicle or full trailer at any load condition and at any braking ratio, the following formulae must be used:

$$f_1 = \frac{T_1}{N_1} = \frac{T_1}{M_1 + \frac{zhM}{E}} \quad f_2 = \frac{T_2}{N_2} = \frac{T_2}{M_2 - \frac{zhM}{E}}$$

where:

$f_1$  and  $f_2$  are the adhesion utilisation values for the front and rear axles;

$T_1$  and  $T_2$  are the brake forces on the front and rear axles;

$N_1$  and  $N_2$  are the dynamic vertical reaction forces at the front and rear axles on the road (i.e., the dynamic load carried on the axle);

$M_1$  and  $M_2$  are the mass carried on the front and rear axle in the static condition;

$z$  is the braking ratio;

$h$  is the height of the combined centre of gravity of the vehicle and the load, measured from the ground;

$M$  is the mass of the vehicle and the load carried, i.e., the sum of  $M_1$  and  $M_2$ ;

$E$  is the wheelbase.

- 10.4 The height of the centre of gravity for a powered vehicle not towing a semi-trailer, and also for a full trailer must be calculated as follows:

$$h = \frac{h_0 \times M_0 + h_1 \times M_1}{M}$$

where:

$h_0$  is the height of the centre of gravity of the unladen vehicle, measured from the ground;

$M_0$  is the mass of the unladen vehicle;

$h_1$  is the height of the centre of gravity of the load, measured from the ground;

$M_1$  is the mass of the load;

$M$  is the combined mass of the vehicle and the load.

- 10.5 The centre of gravity of a laden, powered vehicle towing a semi-trailer must be calculated in a similar way, however, the height of the centre of gravity for the load is the height of the fifth wheel or other coupling around which the semi-trailer pivots, and the mass of the load must be calculated as specified in 7.5.

- 10.6 The braking ratio,  $z$  must be calculated as follows, unless 10.7 applies:

$$z = \frac{\sum T_i}{g \times Md}$$

where:

$T_i$  is the brake force on axle number  $i$ ;

$Md$  is the dynamic mass of the vehicle, which is the mass of the unladen vehicle together with the mass of the load carried and the load, if any, that is transferred onto the vehicle from another vehicle or from the vehicle to another vehicle as a result of braking;

$g$  is the acceleration due to gravity.

- 10.7 The braking ratio for a semi-trailer must be calculated in a similar way to that in 10.6, but instead of the dynamic mass of the vehicle being used, the dynamic load carried on the axle set of the semi-trailer as specified in 9, must be used.
- 11. Information required to ensure compliance with this Specification**
- 11.1 The brake performance of an axle must be provided by the axle manufacturer or brake manufacturer, and must be in the form of output versus input (for example, for hydraulic brakes, brake torque v. hydraulic pressure; for air-operated drum brakes, brake torque v. S-cam torque; or for air-operated disc brakes, brake torque v. air pressure (in the brake chamber)).
- 11.2 The data in 11.1 must be based on tests that were carried out in accordance with one of the standards in 2.5(2) of the Rule, when the brake was fitted to a vehicle with a GVM similar to the vehicle to which the axle is being fitted, and in a position (front or rear) to which the axle is being fitted.
- 11.3 The performance data in 11.1 can only be acceptable as valid for a brake calculation and certification if the brake drum or disc and friction material are identical with the ones that were tested, and the nominal size of the S-cam, brake chamber or cylinder and any other component that may affect the performance of the brake are the same as specified by the axle manufacturer or brake manufacturer.
- 11.4 If the performance of the brake in 11.1 is not available from the vehicle manufacturer or brake manufacturer, it must be established and verified by means of stopping tests. Those verification tests must be carried out with a vehicle sufficiently loaded to prevent premature wheel lock-up during testing, using only the brakes on the axle, the brakes of which are being tested. The tests must be carried out from an initial speed of approximately 50 km/h on a level surface.
- 11.5 During the test in 11.4 the average deceleration of the vehicle and the air or hydraulic pressure, in the brake chamber or cylinder as applicable, must be measured. During the tests, the pressure in the brake chamber or hydraulic cylinder must be steady and be at least 60% of the maximum pressure that occurs at full brake application.
- 11.6 The performance of the brake, when applied as in 11.5, must be calculated from the average deceleration and the pressure, specified in 11.5, the mass of the vehicle during testing and the rolling radius of the tyre measured at the time of the test.
- 11.7 The performance of the brake at low-intensity brake application must be established by measuring the pressure in the brake chamber or cylinder when a brake torque or force is generated that can be detected when the axle of the vehicle is lifted and the brake is gradually applied.
- 11.8 For the purpose of brake calculations, it may be assumed that a linear correlation exists between the brake torque produced by the brake and the pressure in the brake chamber or brake cylinder.
- 11.9 The brake performance as established by means of tests in 11 can only be considered valid for subsequent brake calculations and certifications if the conditions in 11.3 are met.
- 12. Information to be provided to the operator**
- 12.1 The Certifier who certifies a vehicle for compliance with this Specification, or a manufacturer who manufactures a vehicle in compliance with this Specification, must provide the operator with the following information:
- (a) the make, type and grade of the friction materials fitted to the brake;
  - (b) the make, model and type of all valves that are fitted to the brake system
  - (c) the settings of adjustable valves (e.g., ratio valves, pressure limiting valves, etc);
  - (d) the setting and adjustment of the valves that 'self-adjust' during operation (e.g., load sensing valves);
  - (e) the size, including the stroke, of the brake chambers or cylinders;
  - (f) the make, model and type of any other component of the brake that may affect the correct operation of the brake system if replaced with a different make, model or type (e.g., booster cylinders).

Figure 1 - Adhesion utilisation as a function of braking ratio

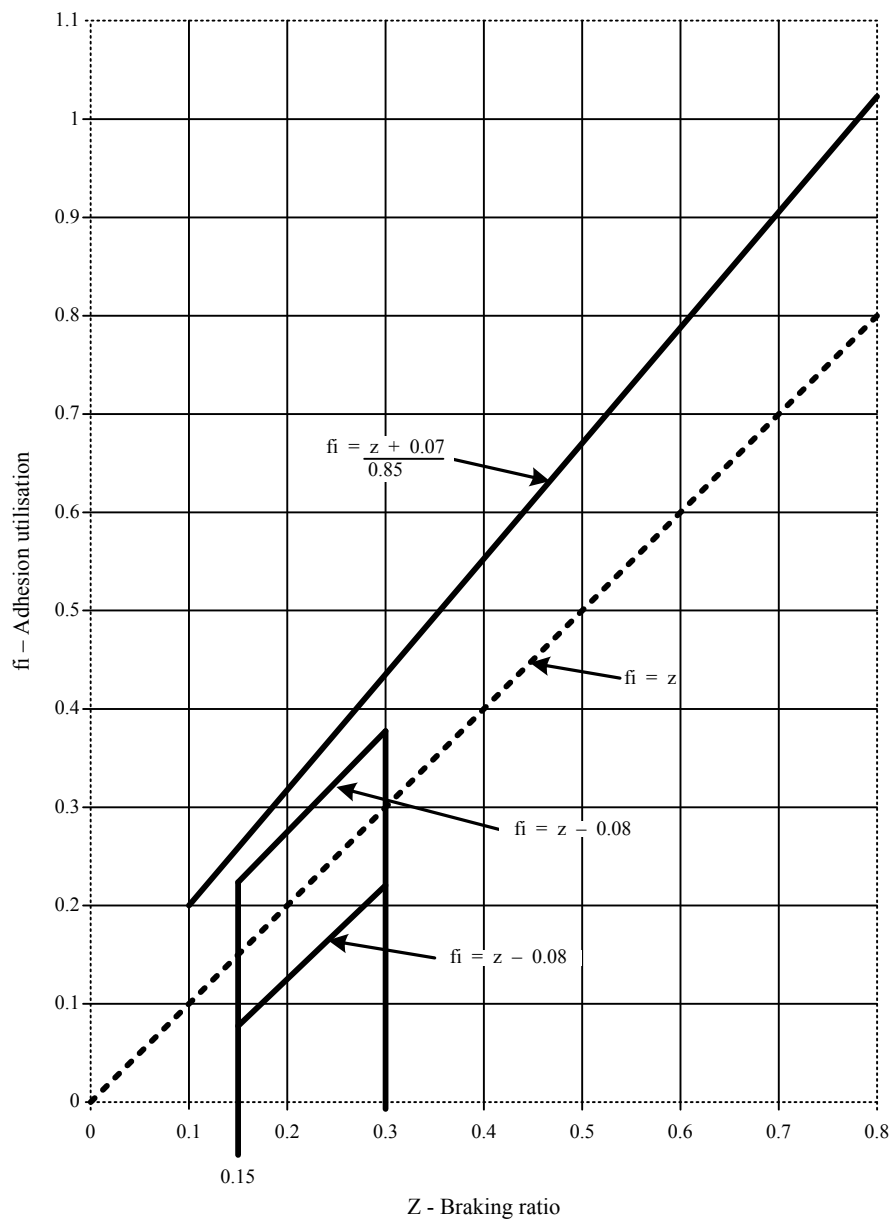

Figure 2 - Braking ratio as a function of control-line pressure

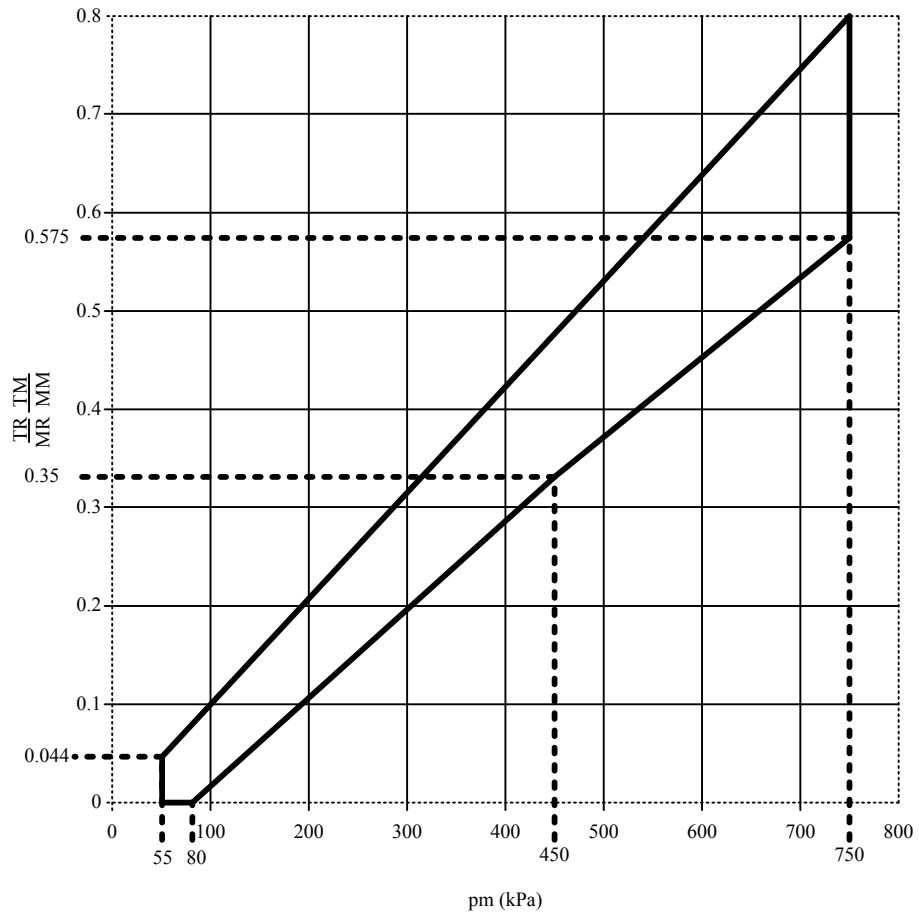
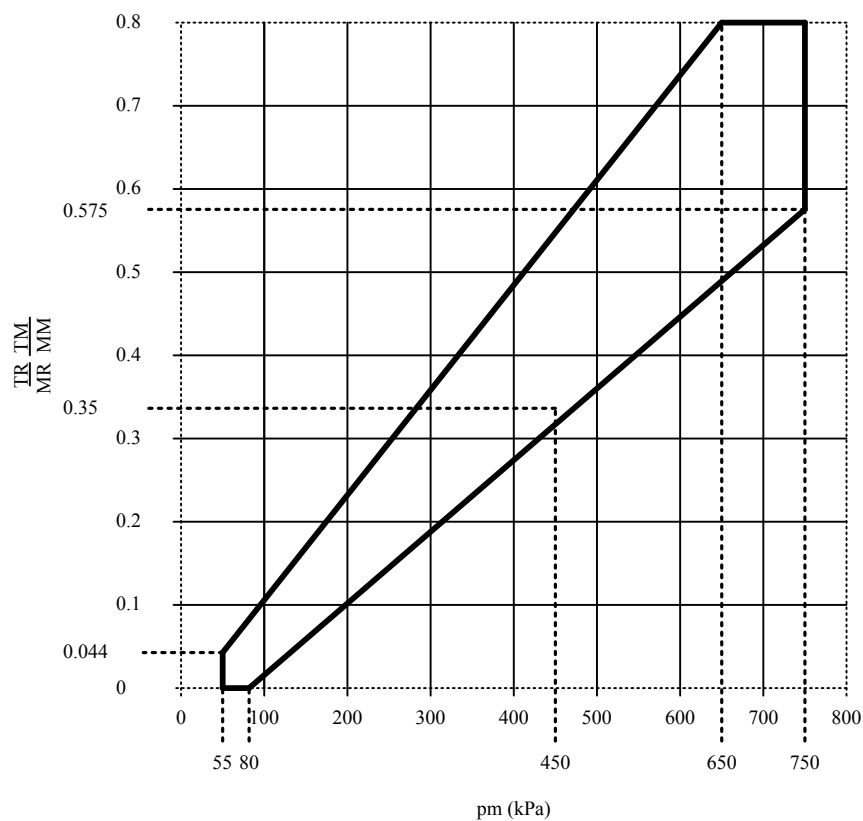

Figure 3 - Braking ratio as a function of control-line pressure (Special case, requires approval from the [Agency])



**Publisher's Note**

This PDF contains information as at 21 June 2009 and is consolidated to include all amendments processed by Brookers editors before that date. The time taken to process legislative consolidations varies according to the size and complexity of amendments. To check for more recent or future amendments to this piece of legislation, please go to [www.brookersonline.co.nz](http://www.brookersonline.co.nz)

